

Best Choice for Maximum Profit!

We at LS Mecapion always make the best efforts to maximize the profits of those who chose our products.

AC Servo User's Manual

L7P INDEXER Series

Ver 1.1



Safety Instructions

- Please read the safety instructions carefully before using the product, and use the products in a proper way.
- After reading this User Manual, please keep it at a place where the manual is always visible to those who use the product.

LS Mecapion

Contents

1

1.	Product Composition.....	1-6
1.1	Product Specification.....	1-6
1.2	Names of Units.....	1-8
1.2.1	Names of Servi Drive Units	1-8
1.2.2	Names of Servo Motor Units	1-11
1.3	Example of System Configuration	1-12
2.	Wiring and Connection.....	2-1
2.1	Servo Motor Installation.....	2-1
2.1.1	User Environment Requirement	2-1
2.1.2	Preventing Excessive Impact.....	2-1
2.1.3	Wiring with Motor.....	2-1
2.1.4	Comibing with Load Device	2-2
2.1.5	Cable Installation.....	2-2
2.2	Servo Driver Installation	2-3
2.2.1	Installation and User Environment.....	2-3
2.3	Drive Blocks	2-4
2.3.1	Drive Blocks(100W ~ 400W)	2-4
2.3.2	Drive Blocks (800W~3.5kW).....	2-5
2.4	Power Unit Wiring.....	2-6
2.4.1	Power Unit Wiring (100W~3.5kW).....	2-7
2.4.2	Power Circuit Electronics Specifications.....	2-8
2.5	Wiring of Input/Output Signal.....	2-9
2.5.1	Names and Functions of Digital Input/Output Signals.....	2-10
2.5.2	Names and Functions of Analog Input/Output Signals.....	2-15
2.5.3	Names and Functions of Pulse train Input Signals	2-17
2.5.4	Names and Functions of Encoder Output Signals	2-17
2.5.5	Example of Input/Output Signal Wiring.....	2-18
2.5.6	Purlse Train Input Signal	2-22
2.5.7	Input/Output Signal Wiring.....	2-23
2.6	Encoder Signal Unit (Connector) Wiring.....	2-24
2.6.1	Option Specifications Connection Example	2-24
2.6.2	Linear Scale and Third party Encoder Connection Example.....	2-29
3.	L7P Indexer Overview.....	3-2
3.1	Control Methods	3-2
3.2	Indexing Position Operation.....	3-2
3.2.1	Coordinate Setting.....	3-7
3.2.2	Index Structure	3-9
3.3	Pulse Input Position Operation	3-10
3.4	Velocity Control	3-1
3.5	Torque Control.....	3-4

4.	Indexing Position Operation	4-7
4.1	Concept of Index	4-7
4.2	Index Type.....	4-17
4.2.1	Absolute / Relative Move.....	4-17
4.2.2	Registration Absolute / Relative Move	4-18
4.2.3	Blending Absolute / Relative Move	4-19
4.2.4	Rotary Absolute / Relative Move.....	4-20
4.2.5	Rotary Shortest Move.....	4-21
4.2.6	Rotary Positive / Negative Move.....	4-21
4.3	Functions of the Index Input Signals.....	4-23
4.4	Functions of the Index Output Signal.....	4-27
4.5	Analog Speed Override	4-29
5.	Pulse Input Position Operation.....	5-1
5.1	Function Setting of Pulse Input Logic	5-2
5.2	Function Setting of Pulse Input Filter	5-3
5.3	Function Setting of PCLEAR	5-3
6.	Velocity Control	6-1
6.1	Fuction Set of Velocity command swtich	6-1
6.2	Analog Velocity Command	6-1
6.3	Digital Speed Command.....	6-3
7.	Torque Control.....	7-4
7.1	Analog Toque Command Scale	7-4
7.2	Speed Setting in Torque Control.....	7-5
8.	The conversion of control mode.....	8-6
9.	Homing	9-8
9.1	Homing Methods	9-9
10.	Application Functions.....	10-2
10.1	Drive Front Panel	10-2
10.1.1	7-Segment for Servo Status Display.....	10-2
10.1.2	Drove Node Address Setting	10-5
10.1.3	Terminating Resistance Setting	10-6
10.2	Input/Output Signal Setting.....	10-7
10.2.1	Allocating Digital Input Signals	10-7
10.2.2	Allocating Digital Output Signals.....	10-10
10.2.3	Using User I/O.....	10-14
10.3	Electronic Gear Setting.....	10-18
10.3.1	Electronic Gear.....	10-18
10.3.2	Examples of Electronic Gear Setting	10-20
10.4	Settings Related with Speed Control	10-21
10.4.1	Smooth Acceleration/Deceleration.....	10-21
10.4.2	Servo-lock Function.....	10-22
10.4.3	Signals Related with Speed Control	10-22

10.5	Settings Related with Position Control.....	10-23
10.5.1	Position Command Filter	10-23
10.5.2	Signals Related with Position Control	10-25
10.6	Forward/Reverse Limit Setting	10-26
10.7	Brake Output Signal Function Setting.....	10-27
10.8	Torque Limit Function	10-29
10.9	Gain Conversion.....	10-32
10.9.1	Gain Group Conversion	10-32
10.9.2	P/PI Control Conversion	10-34
10.10	Dynamic Brake	10-36
10.11	Regeneratiion BrakeResistorSetting	10-38
10.11.1	Using Internal Regeneration brake resistor	10-39
10.11.2	Using External Regeneration brake resistor	10-41
10.11.3	Other Considerations.....	10-42
10.12	Encoder Signal Output.....	10-43
10.13	Absolute Encoder Data Transmission (ABSRQ)	10-45
11.	Tuning.....	11-46
11.1	Automatic Gain Tuning	11-46
11.2	ManualGainTuning	11-48
11.2.1	Order Gain Tuning.....	11-48
11.3	Vibration Control.....	11-49
11.3.1	NotchFilter	11-50
11.3.2	Adaptive Filter	11-51
11.4	AnalogMonitor	11-52
12.	Procedure Functions	12-1
12.1	Manual Jog Operation	12-1
12.2	Program Jog Operation	12-2
12.3	Alarm Record Deleting	12-3
12.4	AutomaticGainTuning	12-5
12.5	IndexPulse Search	12-5
12.6	Absolute Encder Setting	12-6
12.7	Instantaneous Maximum Torque Reset	12-6
12.8	Phase Current Offset Tuning	12-7
12.9	Software Reset.....	12-7
12.10	Commutation	12-8
13.	Object Dictionary	13-9
13.1	Data Type.....	13-9
13.2	General Objects	13-9
13.3	Manufacturer Specific Objects.....	13-14
13.4	Index Objects	13-79
13.5	CiA402 Objects	13-84

14. Maintenance and Checkup	14-1
14.1 Abnormality Diagnosis and Actions	14-1
14.2 Servo Alarm.....	14-1
14.3 Servo Warning.....	14-7
15. Communication Protocol	15-1
15.1 Overview and Communication Specifications	15-1
15.1.1 Overview	15-1
15.1.2 Communication Specifications and Connection Diagram	15-2
15.2 Basic Structure of Communication Protocol	15-3
15.2.1 Transmission/Reception Packet Structure.....	15-3
15.2.2 ProtocoleCommand CodeDescriptions.....	15-5
15.3 L7P Indexer Servo Drive Communication Address Table.....	15-18
15.3.1 System Configuration Parameters.....	15-18
15.3.2 Control Parameters	15-19
15.3.3 Input and Output Parameters	15-21
15.3.4 Speed Operation Parameters.....	15-22
15.3.5 Miscellaneous Parameters	15-23
15.3.6 Advanced Control Parameters	15-24
15.3.7 Monitoring Parameters	15-25
15.3.8 Procedures and Alarm History.....	15-26
15.3.9 3rd Party Motor Parameters	15-26
15.3.10 CiA402 parameters	15-27
15.3.11 Index Related Parameters.....	15-29
16. Product Features	16-1
16.1 Servo Motor.....	16-1
16.1.1 Outside View	16-26
16.2 ServoDrive	16-39
16.2.1 Product Features.....	16-39
16.2.2 Outside View	16-42
16.3 Options and Peripherals.....	16-45
17. Commission	17-1
17.1 Preparation for Operation	17-2
17.1.1 Indexing Position Operation	17-3
17.1.2 Pulse Input Position Operation	17-4
17.2 Examples of Connection wint Host Device (Pulse Input Position).....	17-5
17.2.1 Connection with LSIS XGF-PD1/2/3A	17-5
17.2.2 Connection with LSIS XGF-PO1/2/3A	17-6
17.2.3 Example of Connection with XGF-PD1/2/3H of LSIS.....	17-7
17.2.4 Example of Connection with XGF-PO1/2/3H of LSIS	17-8
18. Appendix	18-1
18.1 Firmware Update.....	18-1
18.1.1 Using USB OTG	18-1
18.1.2 Using Drive CM	18-2

1. Product Composition

1.1 Product Specification

■ L7P Series Product Format

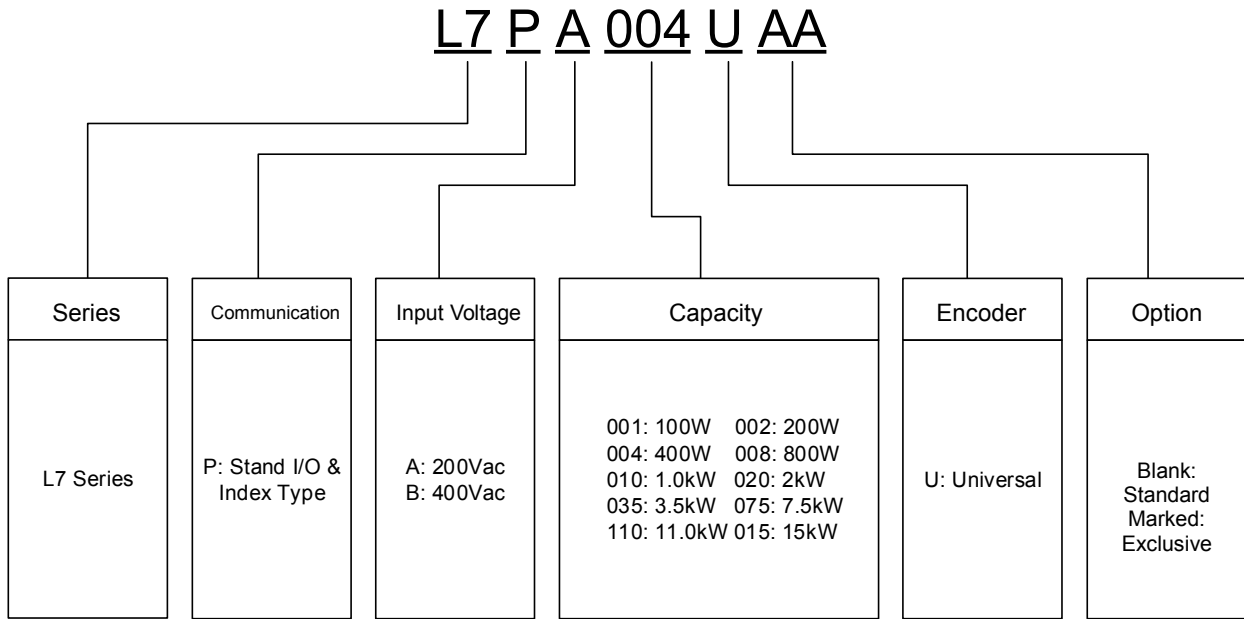

■ Servo Motor Product Format

APM – S B 04 A N K 1 G1 03

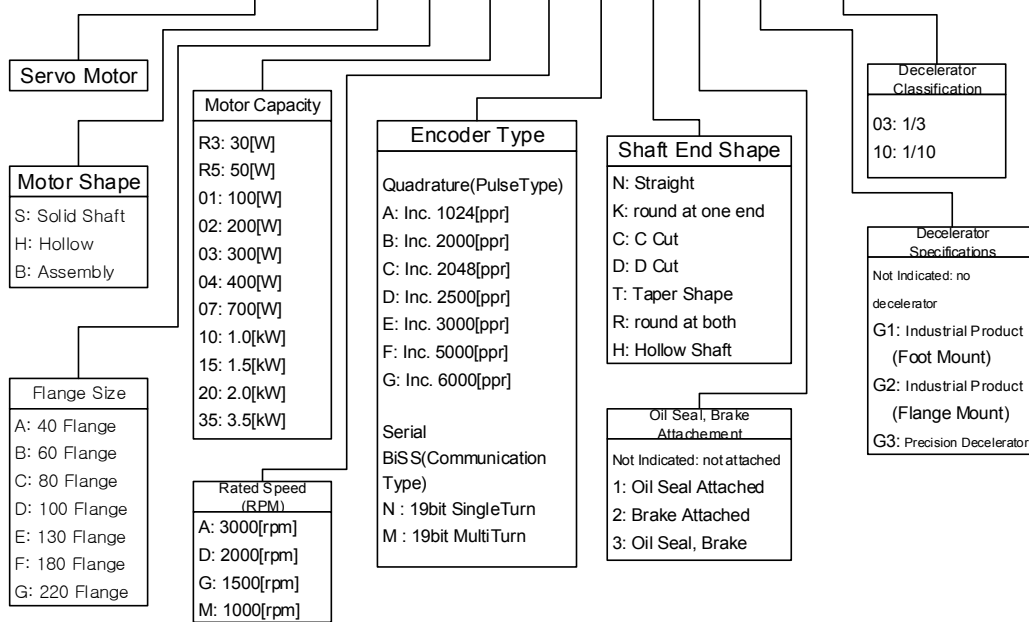

1.2 Names of Units

1.2.1 Names of Servi Drive Units

■ 100W, 200W, 400W

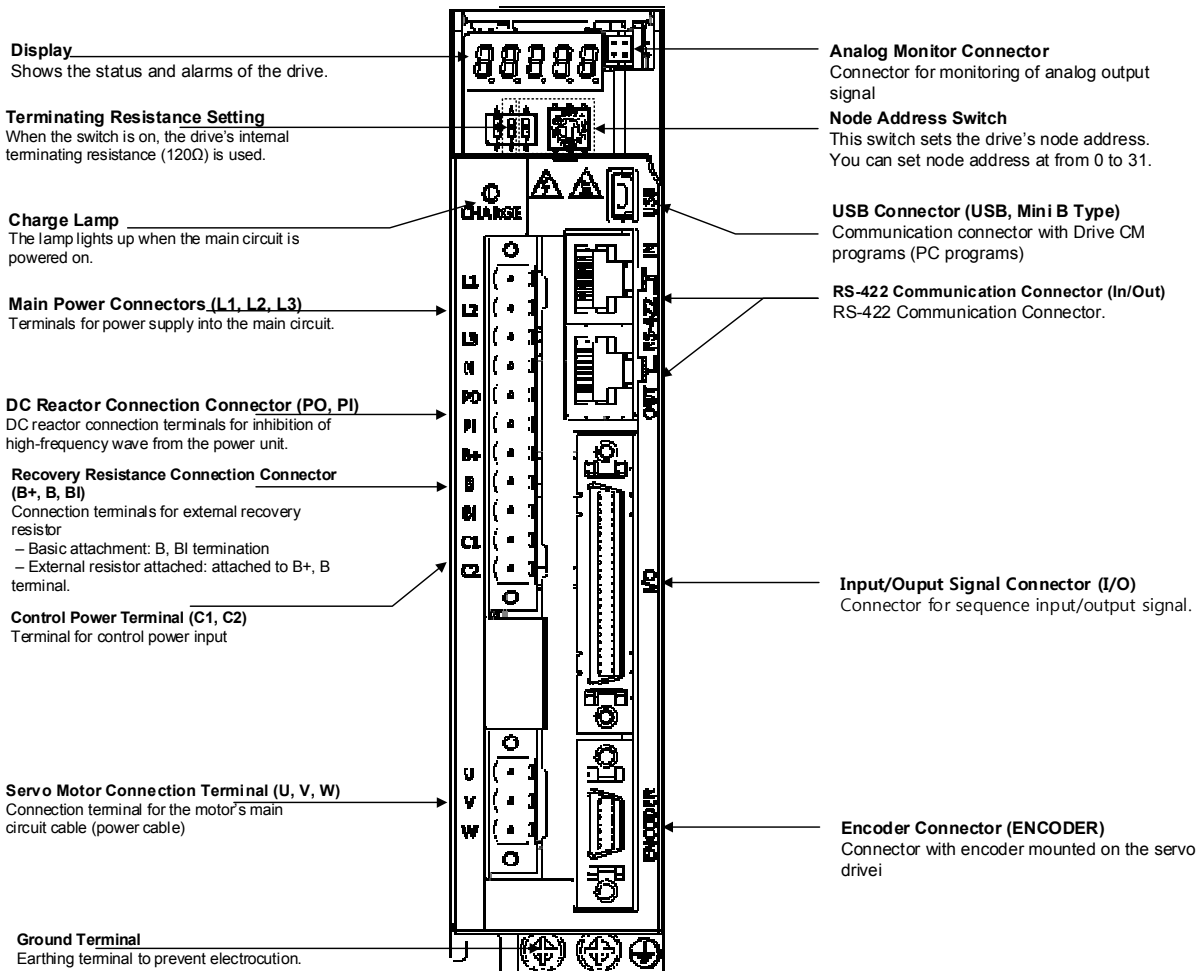

■ 800W, 1kW

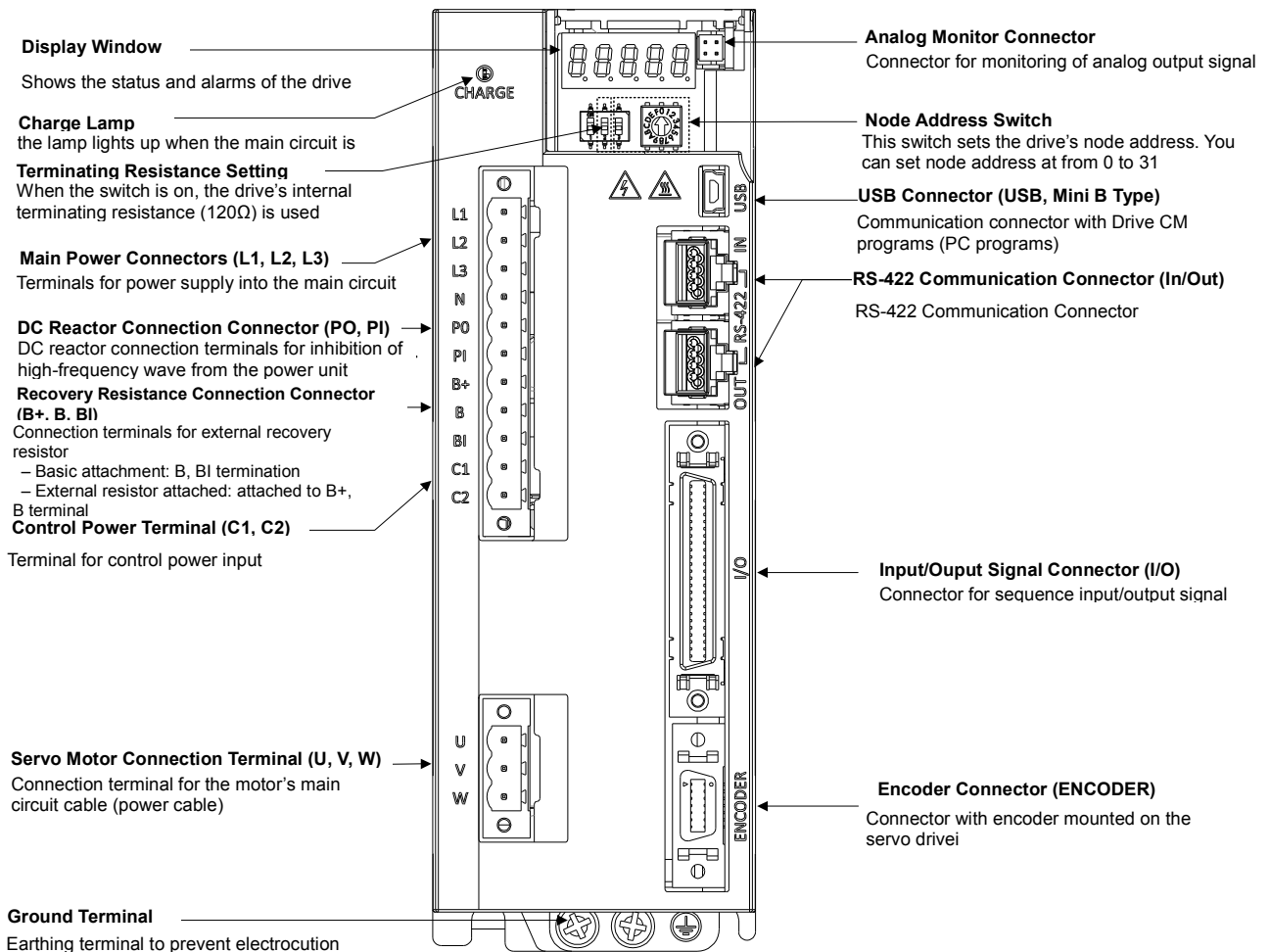

■ 2kW, 3.5kW

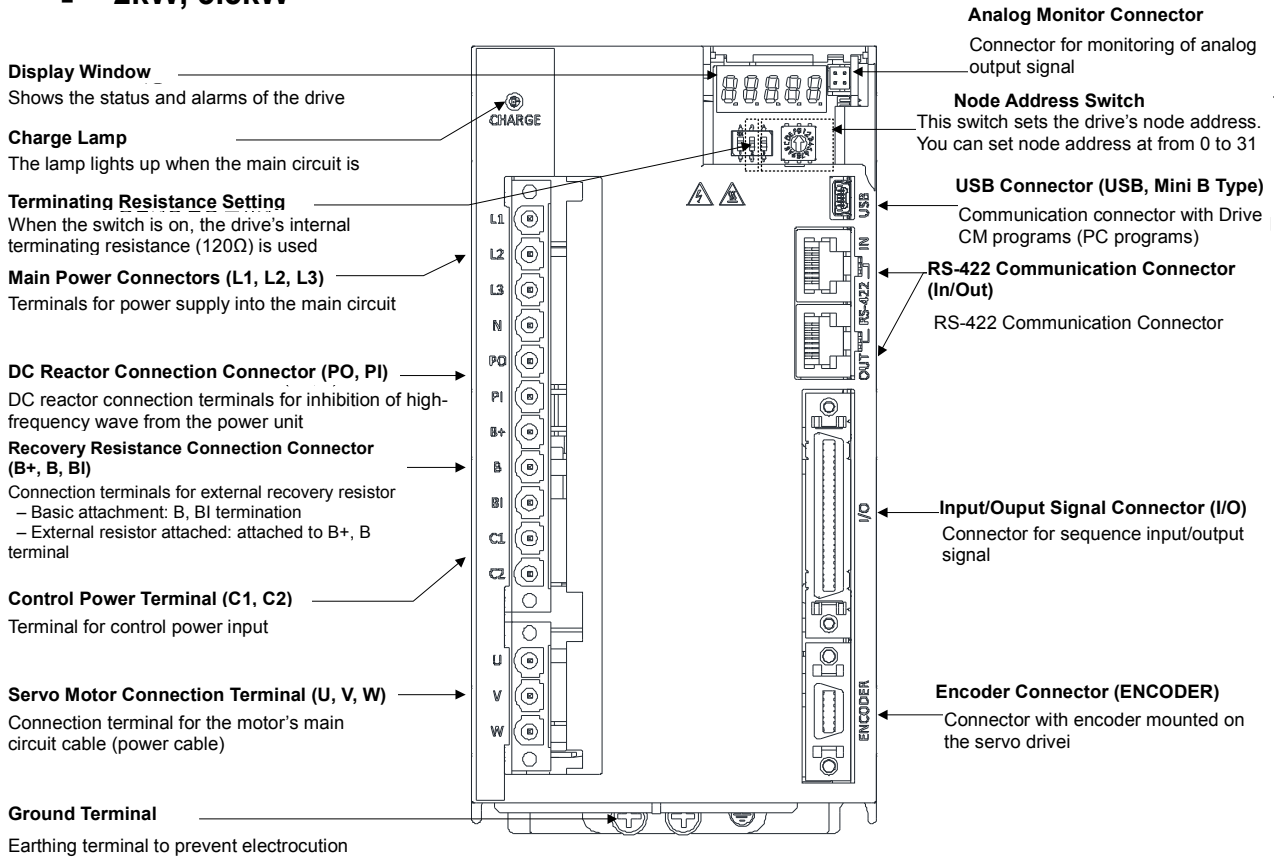

1.2.2 Names of Servo Motor Units

■ 80 Flange or Below

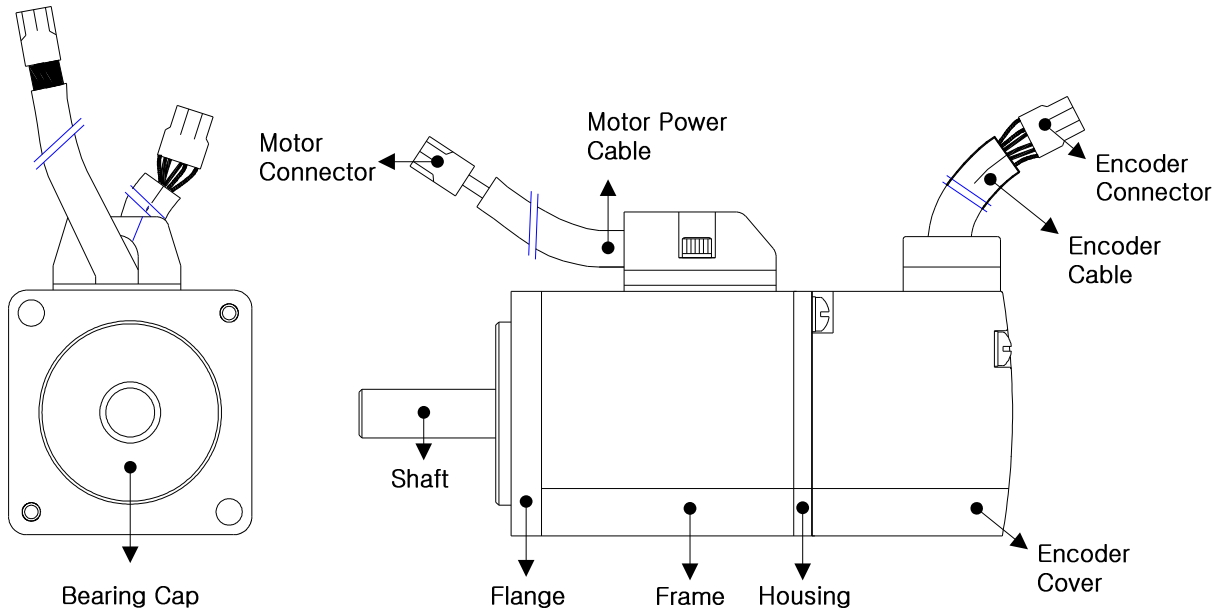

■ 130 Flange or Above

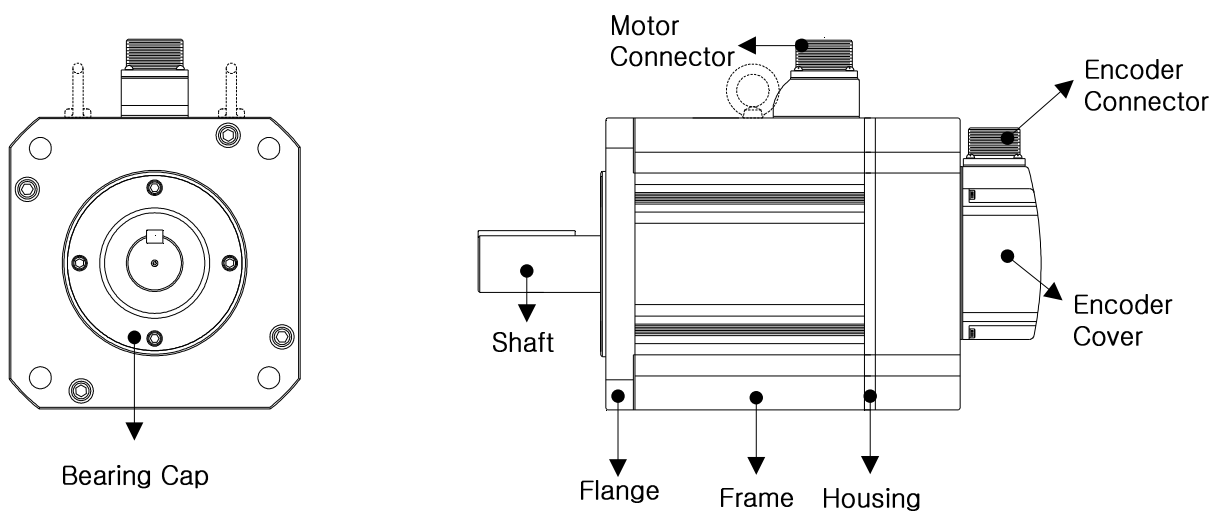

1.3 Example of System Configuration

The figure below shows an example system constructed using this product.

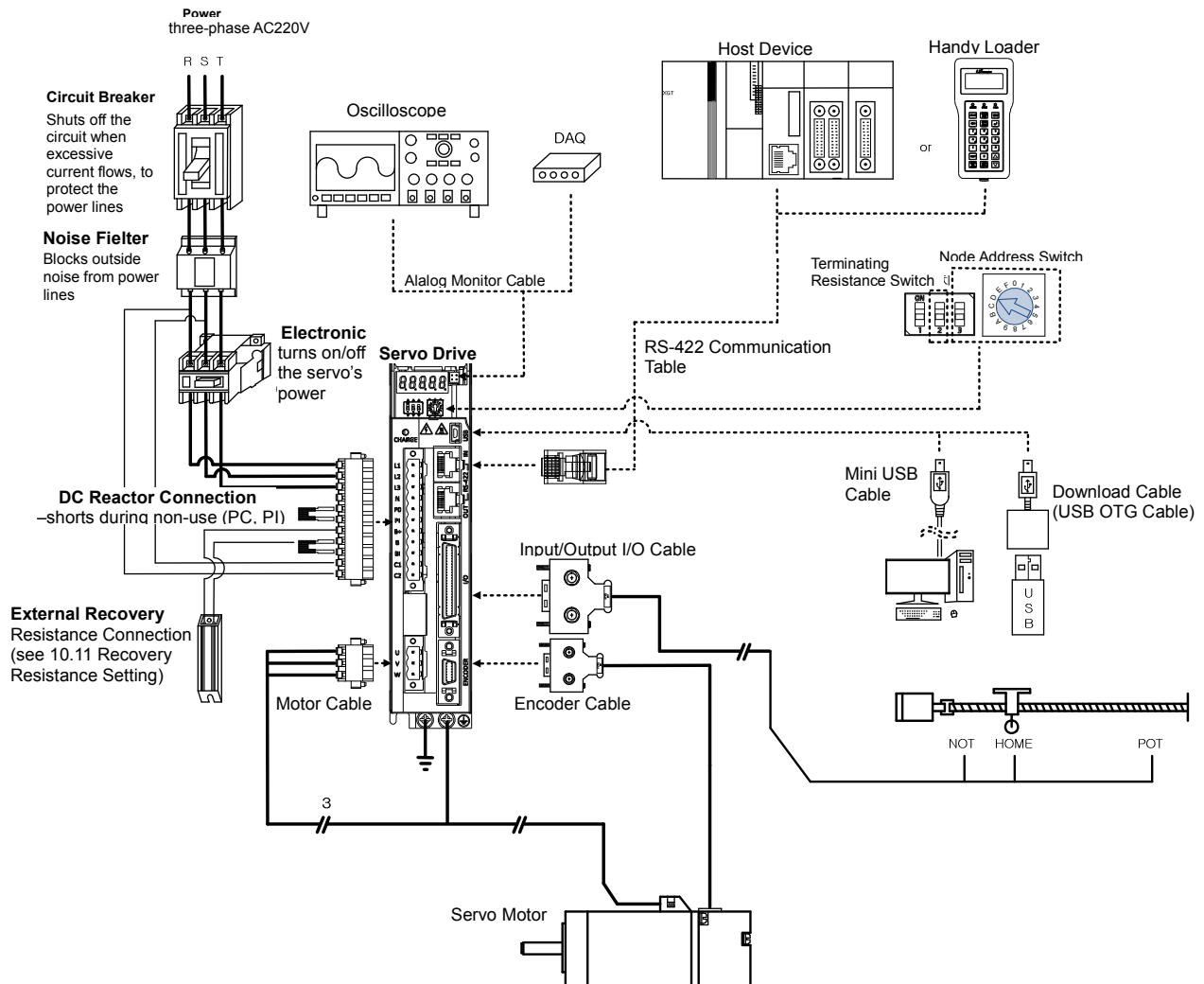

2. Wiring and Connection

2.1 Servo Motor Installation

2.1.1 User Environment Requirement

Items	Environment Requirements	Notes
Surrounding Temperature	0 ~ 40[°C]	When the temperature exceeds the workable temperature, a separate command must be placed after consulting with the Tech Department
Surrounding Humidity	80[%]RH or below	Please use the product where no steam is generated
External Vibration	Vibration Acceleration X, Y direction / 19.6[m/s ²] or below	Excessive vibration may shorten the life cycle of the bearings

2.1.2 Preventing Excessive Impact

Excessive impact on the motor during installation or accidental fall may destroy the encoder.

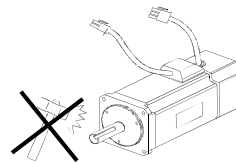

2.1.3 Wiring with Motor

- Directly connecting the motor with commercial power damages the motor. Please use the designated drive to connect power.
- Please connect the earthing terminal of the motor to one of the two earthing terminals of the drive, and connect the other terminal with a Type-3 ground connection.

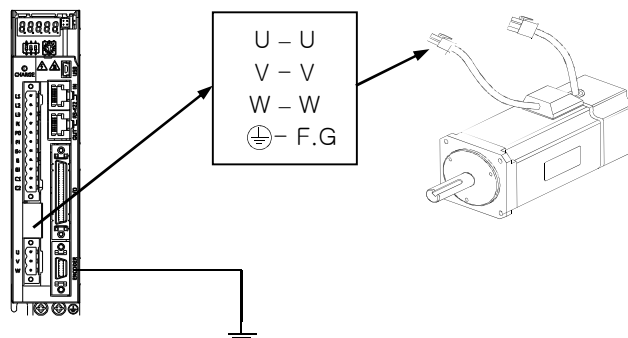

- Please match the U, V, W terminals of the motor with the U, V, W terminals of the drive.
- Please check the motor connector for any missing pin or bad contact.
- If the motor has humidity or condensation, please check if the insulation resistance is 10[MΩ] or more (500[V]), and install the product only when there is no problem.

2.1.4 Comibing with Load Device

Coupling Combining: install coupling by matching the motor shaft with the load shaft within the permissible window.

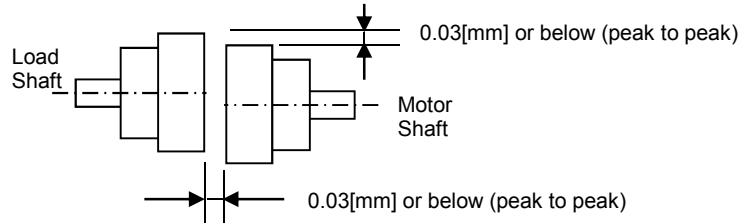

■ Pulley Combining:

Flange	Radial Load		Shaft Load		Note
	N	Kgf	N	kgf	
40	148	15	39	4	
60	206	21	69	7	
80	255	26	98	10	
130	725	74	362	37	
180	1548	158	519	53	
220	1850	189	781	90	

2.1.5 Cable Installation

- When installing the product vertically, please make sure no oil or water flows into the connection unit.

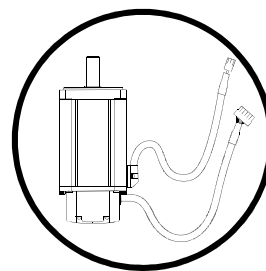
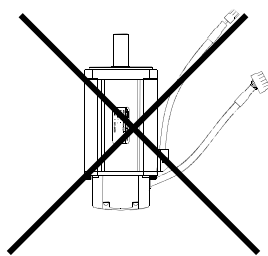

- Please do not stress or damage the cable. When moving the motor, please use movable cable and make sure the cable does not wiggle.

2.2 Servo Driver Installation

2.2.1 Installation and User Environment

Items	Environment Requirements	Notes
Surrounding Temperature	0~50[°C]	⚠ Caution Please attach the cooling fan to the control panel, so that the temperature does not exceed the workable temperature.
Surrounding Humidity	90[%]RH or below	⚠ Caution Freezing or condensation inside the drive due to long-term non-use may damage the drive. When operating after non-use, please remove water before operating.
External Vibration	Vibration Acceleration 4.9[m/s ²] or below	Excessive vibration may shorten the life cycle of the bearings
Environmental Requirements	<ul style="list-style-type: none"> ▪ No exposure to direct sunlight ▪ No corrosive/flammable gas ▪ No oil or dust ▪ In case of a closed space, adequate ventilation 	

2.3 Drive Blocks

2.3.1 Drive Blocks(100W ~ 400W)

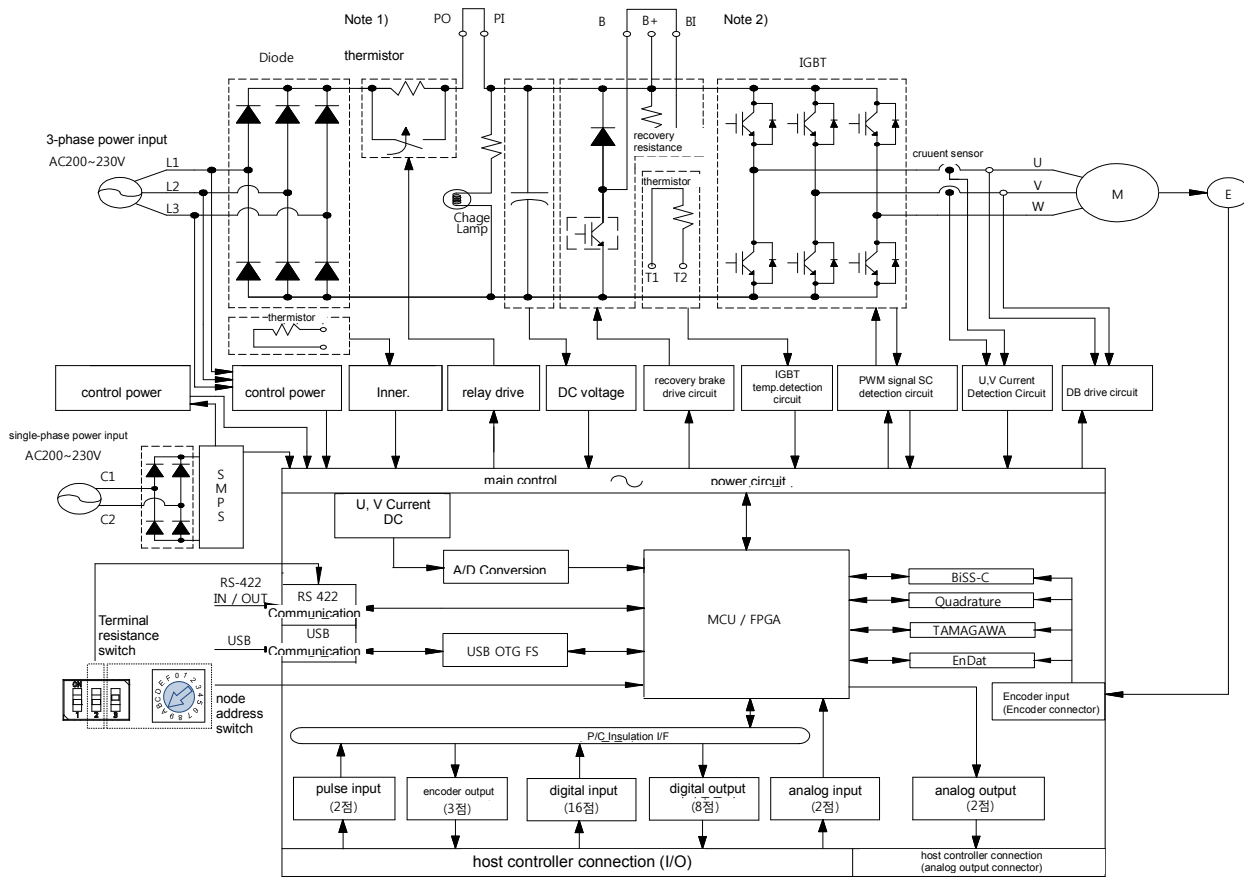

Note 1)When using DC reactor, please connect with PO, PI.

Note 2)When using external recovery resistance, remove the shorting pins B, BI and then connect with the B+, B pins.

2.3.2 Drive Blocks (800W~3.5kW)

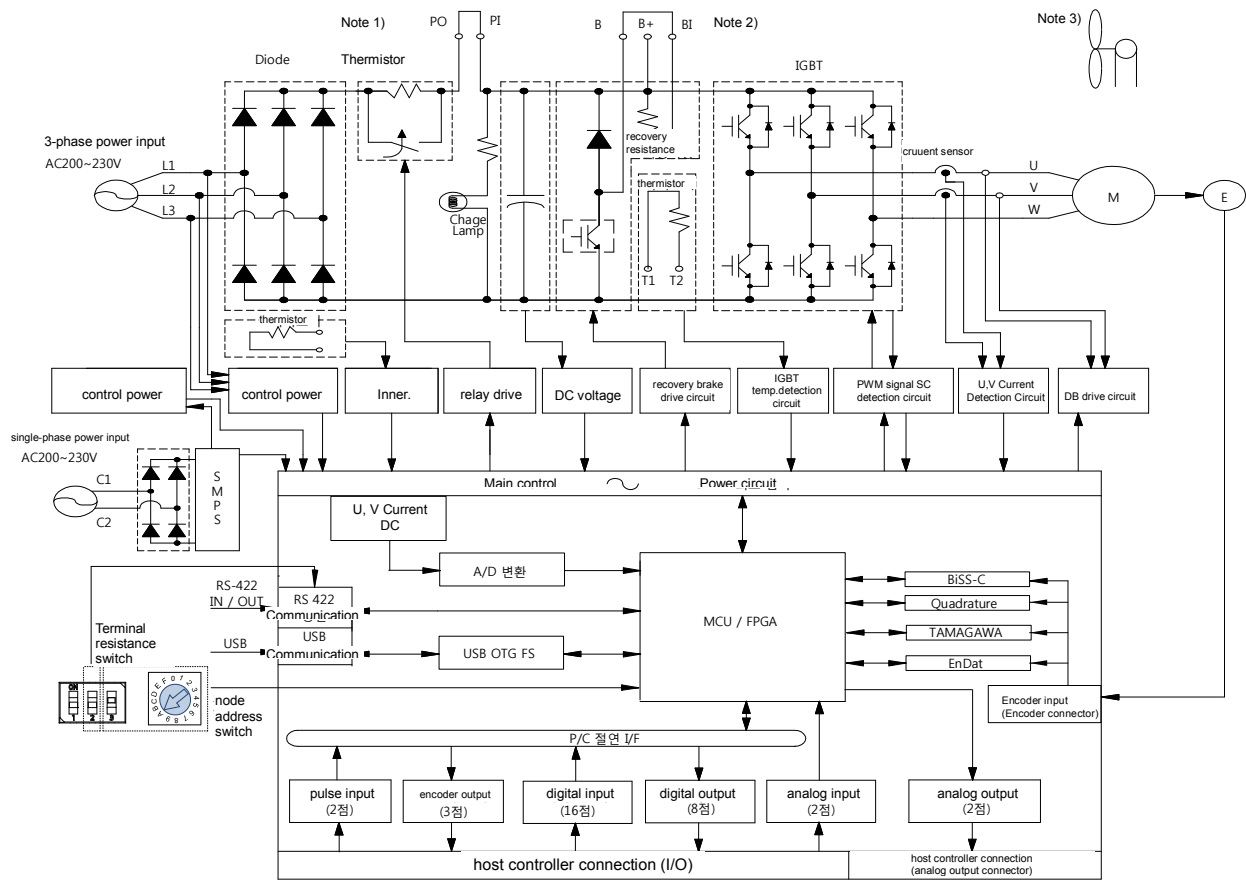

Note 1) When using DC reactor, please connect with PO, PI.

Note 2) When using external recovery resistance, remove the shorting pins B, BI and then connect with the B+, B pins.

Note 3) 800[W]~3.5kW Model is force-cooled with DC-24[V] cooling fan.

2.4 Power Unit Wiring

- Please check the voltage of the input power so that it does not exceed the permissible window.

⚠ Caution
Connecting excessive voltage will damage the drive

- Connecting commercial power with the drive's U, V, W terminals may cause damage. Please connect the power to the L1, L2, L3 terminals.
- Please use the product by connecting shorting pins to the drive's B, BI terminals. And when using an external recovery resistance, please connect with the B+, B terminals after removing the shorting pin, at the standard resistance.

Type	Resistance	Standard Capacity	* Notes
100[W]	100[Ω]	Internal 50[W]	⚠ Caution Please see "16.3 Options and Peripherals" for resistance values when expanding recovery capacity
200[W]			
400[W]			
800[W]	40[Ω]	Internal 100[W]	
1[kW]			
2[kW]	13[Ω]	Internal 150[W]	
3.5[kW]			

- Please construct the system so that the main power (L1, L2, L3) is always supplied after the control power (C1, C2) is supplied (see "2.4.1 Power Unit Wiring")
- High voltage remains even after the main power is shut off. Please exercise caution.

⚡ Danger
Start re-wiring after making sure that the charge lamp is off after shutting off the main power, to avoid being electrocuted.

- The length of the earthing cable should be as short as possible. Too long cables may cause noises that might cause malfunction.

2.4.1 Power Unit Wiring (100W~3.5kW)

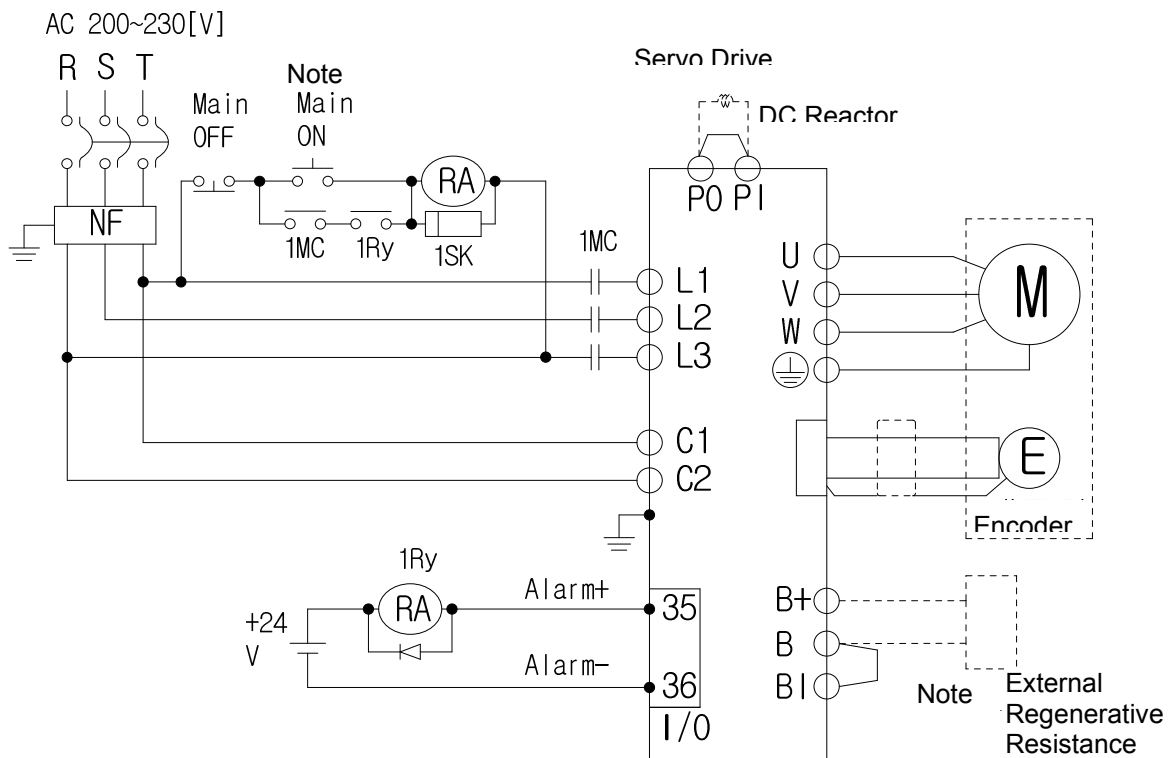

Note 1) Please press the ON switch for the main power for at least 2 seconds, as the alarm signal input takes 1~2 seconds after the main power is turned on.

Note 2) 100[W]~400[W] drive has built-in recovery resistance of 50[W], 100[Ω]; 800[W]~1[kW] drive has 100[W], 40[Ω]; and 2[kW]~3.5[kW] drive has 150[W], 13[Ω] recovery resistance. Please use them by shorting terminals B and BI. If the recovery resistance is high due to frequent acceleration/deceleration, please open the shorting pins (B, BI) and connect external recovery resistance to B, B+.

Note 3) Please peel off the 7~10[mm] of the sheath of the power cable to be used for the power unit as shown in the figure below. And use the dedicated pressure terminal (see "2.4.2 Power Circuit Electronics Specifications")

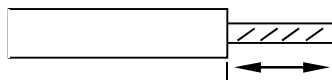

Note 4) When removing power unit wiring from 100[W]~1[kW] drive, remove or connect it after pressing the button at the drive's terminal block. In case of 2[kW]~3.5[kW] drive, remove or connect it using a flat-head driver.

2.4.2 Power Circuit Electronics Specifications

Type	100W	200W	400W	800W	1kW	2kW	3.5kW
MCCB	ABS33bM(8A)			12A		24A	
Noise Filter (NF)	RFY-4010M					4020M	4030M
DC Reactor	HFN-6(6A)			HFN-10(10A)		HFN-30(30A)	
MC	GMC-9(11A)			GMC-18(18A)		GMC-40(35A)	
Power Cable	AWG16 (1.25 SQ)			AWG14 (2.0 SQ)		AWG12 (4.0 SQ)	
Pressure Terminal	UA-F1510, SEOIL (10mm Strip & Twist)			UA-F2010, SEOIL (10mm Strip & Twist)		UA-F4010, SEOIL (10mm Strip & Twist)	
Recovery Resistance (default)	50[W] 100Ω			100[W] 40Ω		150[W] 13Ω	

2.5 Wiring of Input/Output Signal

■ I/O Connector Specifications: 10120-3000PE(3M)

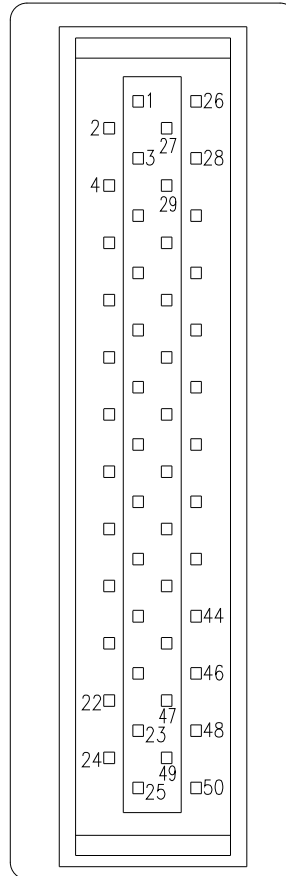

■ Analog Monitoring Connector Specifications: DF-11-4DS-2C (HIROSE)

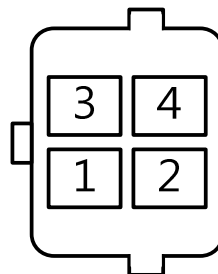

2.5.1 Names and Functions of Digital Input/Output Signals

■ Names and Functions of Digital Input Signals(I/OConnector)

Pin No.	Name	Allotment	Description	Function Details
21, 11	+24V	DC 24V	DC 24V INPUT	COMMON
12	DI1	SVON	Servo ON	When the SVON signal is ON, the product is operational (Servo ON) When the signal is OFF, the motor goes into the free run state.
13	DI 2	POT	No forward(CCW) rotation	The motor is stopped so that the actuator cannot rotate forward more than the set motion window [0x2013] The set value determines how it stops.
14	DI3	NOT	No backwad(CW) rotation	The motor is stopped so that the actuator cannot rotate reverse more than the set motion window [0x2013] The set value determines how it stops.
15	DI4	A-RST	Alarm reset	Turns off the Servo alarm.
16	DI 5	START	Initiate operation	Intiatesoperation to the index position operation.
17	DI 6	STOP	Stop servo	Stops operation.
18	DI 7	REGT	Post-sensor operation	If the index type is registration absolute orregistration Relative, when the REGT signal is on, the speed and distance is changed to the preset speed and distance.
19	DI 8	EMG	Emergency stop	When the EMG signal is on, the servo makes an emergency stop, generating 'W-80'. [0x2013] The set value determines how it stops.
22	DI 9	HOME	Origin Sensor	Home sensor input signal, used when returning to the origin.
23	DI 10	HSTART	Initiate Origin Operation	Initiates operation back to the origin
24	DI 11	ISEL0	Select Index 0	Select an index for operation among index 0 to 63.
25	DI 12	ISEL1	Select Index 1	
26	DI 13	ISEL2	Select Index 2	
27	DI 14	ISEL3	Select Index 3	
28	DI 15	ISEL4	Select Index 4	
29	DI 16	ISEL5	Select Index 5	
** PCON			P Control Action	When the PCON signal is on, PI control changes to P control.
** GAIN2			Gain 1,2 Transfer	When the GAIN2 signal is on, the speed control changes from Gain 1 to Gain 2.
** PCL			Limit positive torque	When the PCL signal is on, positive torque is limited. [0x2110] You can preset the action, and the torque limit is determined by [0x2111].

** NCL	Limit negative torque	When the NCL signal is on, positive torque is limited. [0x2110] You can preset the action, and the torque limit is determined by [0x2111].
** PAUSE	Pause	Inputting the PAUSE signal during index operation will slow down and stop the motor. And when the PAUSE signal is re-entered, the operation to the original index resumes.
** ABSRQ	Absolute position data request	Upon request of the absolute data of the absolute encoder, the data of the absolute encoder is transmitted to a Host controller in quadrature pulse format through AO, BO output.
** JSTART	Jog operation	When the signal is ON, Jog operation begins at a speed set by [0x2300].
** JDIR	Select jog rotation direction	Changes rotation direction for jog operation
** PCLR	Clear input pulse	When the signal is ON, the input pulse is not received and the position error becomes 0. Operation mode can be set at [0x3005].
** AOVR	Select speed override	When the AOVR signal is ON, the index operation speed is overridden in accordance with the voltage input into the A-OVR(AI2) The override value is 0% under -10V input, 100% under 0V input, and 200% under +10V input.

** SPD1	Digital Speed 1	Selecting command speed for Depending on Speed Digital Input contact, Speed command is changed as below			
		Input device			Speed
		SPD1	SPD2	SPD3	
		X	X	X	Speed Command 1 (Parameter 0x2312)
		O	X	X	Speed Command 2 (Parameter 0x2313)
		X	O	X	Speed Command 3 (Parameter 0x2314)
		O	O	X	Speed Command 4 (Parameter 0x2315)
		X	X	O	Speed Command 5 (Parameter 0x2316)
		O	X	O	Speed Command 6 (Parameter 0x2317)
X	O	O	Speed Command 7 (Parameter 0x2318)		
O	O	O	Speed Command 8 (Parameter 0x2319)		
** SPD2	Digital Speed 2	When the AOVR signal is ON, the index operation speed is overridden in accordance with the voltage input into the A-OVR(AI2) The override value is 0% under -10Vinput, 100% under 0V input, and 200% under + 10V input.			
** SPD3	Digital Speed 3	Selecting command speed for Depending on Speed Digital Input contact, Speed command is changed as below			
** MODE	Conversion of control mode				

	Input device			Speed
	SPD1	SPD2	SPD3	
	X	X	X	Speed Command 1 (Parameter 0x2312)
	O	X	X	Speed Command 2 (Parameter 0x2313)
	X	O	X	Speed Command 3 (Parameter 0x2314)
	O	O	X	Speed Command 4 (Parameter 0x2315)
	X	X	O	Speed Command 5 (Parameter 0x2316)
	O	X	O	Speed Command 6 (Parameter 0x2317)
	X	O	O	Speed Command 7 (Parameter 0x2318)
	O	O	O	Speed Command 8 (Parameter 0x2319)
To covert control mode during operation				

Note 5)**These signals are not allotted at the time of the product's release from the factory. You can change allotment by configuring the parameters. Please see 「10.2 Input/Output Signal Setting」 for further details.

Note 6)You may perform wiring by using the COMMON (DC 24V) of the input signal as GND.

■ Names and Functions of Digital Input Signals(I/OConnector)

Pin No.	Name	Allotment	Description	Function Details
35	DO1+	ALARM+	Servo alarm	This signal is displayed when the servo alarm sets off.
36	DO1-	ALARM-		
37	DO2+	RDY+	Servoready	This signal is displayed when the main power is on and the servo is operational.
38	DO2-	RDY-		
39	DO3+	BRAKE+	Brake	This signal is for controlling brakes installed inside or outside the motor. It is displayed when the SVON contact is off.
40	DO3-	BRAKE-		
41	DO4+	INPOS1+	Position reached 1	This signal is displayed when the command position is reached. You can set the display conditions by adjusting the [0x2401], [0x2402] values.
42	DO4-	INPOS1-		
43	DO5+	ORG+	Original position reached	This signal is displayed when origin operation is complete.
44	DO5-	ORG-		
45	DO6+	EOS+	Operation complete	This signal is displayed when index operation is complete.
46	DO6-	EOS-		
47	DO7+	TGON+	Rotation detection	This signal is displayed when the motor rotates faster than the set [0x2405] value.
48	DO7-	TGON-		
49	DO8+	TLMT+	Torque limit	This signal is displayed when the drive output is limited within the set torque limit value.
50	DO8-	TLMT-		
** VLMT			Speed limit	This signal is displayed when the motor reaches the speed limit. The speed limit can be adjusted by setting the [0x230D], [0x230E] values.
** INSPD			Speed reached	This signal is displayed when the difference between the command speed and the current speed is under the set [0x2406] value.
** WARN			Servo warning	This signal is displayed when a warning sets off.
** INPOS2			Position reached 2	This signal is displayed when the command position is reached. You can set the display conditions by adjusting the [0x2401], [0x2402] values.
** IOUT0			Index output0	This signal displays the number of the index currently performed (0~63)
** IOUT1			Index output1	
** IOUT2			Index output2	
** IOUT3			Index output3	
** IOUT4			Index output4	
** IOUT5			Index output5	

**These signals are not allotted at the time of the product's release from the factory. You can change allotment by configuring the parameters. Please see 「10.2 Input/Output Signal Setting」 for further details.

2.5.2 Names and Functions of Analog Input/Output Signals

■ Names and Functions of Analog Input Signals (I/OConnector)

Pin No.	Name	Description	Function Details
7	A-TLMT	Analog Torque Input(Command/ Limit)	<p>Index operation mode :</p> <p>-10~ + 10V is connected between A-TLMT(AI1) and AGND to limit the motor's output torque. The relationship between input voltage and torque limit varies depending on the set [0x221C] value.</p> <p>Torque operation mode :</p> <p>-10~ + 10V is connected between A-TLMT(AI1) and AGND to operate torque command. The relationship between input voltage and torque command varies depending on the set [0x221C] value.</p>
9	A-OVR	Analog Speed Input(Command/Override)	<p>Index operation mode :</p> <p>-10~ + 10V is connected between A-OVR(AI2) and AGND to override index operation speed. The override value is 0% under -10V input, 100% under 0V input, and 200% under +10V input. You can choose whether to use this function by [0x221E] or AVOR contact input.</p> <p>Speed operation mode :</p> <p>-10~ + 10V is connected between A-OVR(AI2) and AGND to operate Analog speed mode. The relationship between input voltage and speed command varies depending on the set [0x2229] value.</p>
8	AGND	AGND(0V)	Analog ground
10	AGND	AGND(0V)	Analog ground

■ Names and Functions of Analog Output Signals(Analog Monitoring Connector)

Pin No.	Name	Description	Function Details
1	AMON1	Analog monitor 1	Analog monitor output(-10V ~ +10V)
2	AMON2	Analog monitor 2	Analog monitor output(-10V ~ +10V)
3	AGND	AGND(0V)	Analog ground

4	AGND	AGND(0V)	Analog ground
---	------	----------	---------------

You can change the output variables to monitor through analog monitor output by adjusting the parameters. Please see 「11.4 Analog Monitor」 for further details.

2.5.3 Names and Functions of Pulse train Input Signals

■ Pulse train Input Signals(I/OConnector)

Pin No.	Name	Description	Function Details
30	PULCOM	+24[V] power input	Inputs command pulse train. Inputs forward pulse train between PF+ and PF-, and inputs reverse pulse train between PR+ and PR-. The action is performed when the Pulse Input Position is selected at [0x3000]. Pulse logic can be configured at [0x3003], and the pulse input filter can be configured at [0x3004]. When using the line drive method, the maximum input frequency is 1Mpps. When using the open collector method, the maximum input frequency is 200kpps.
31	PF+		
32	PF-		
33	PR+		
34	PR-		

2.5.4 Names and Functions of Encoder Output Signals

■ Encoder Output Signal (I/OConnector)

Pin No.	명칭	Description	Function Details
1	AO	Ebcider A Signal	Encoder signals A, B, Z are displayed in line drive forms. The number of pulses displayed can be set at [0x3006].
2	/AO		
3	BO	Ebcider B Signal	
4	/BO		
5	ZO	Ebcider Z Signal	
6	/ZO		

2.5.5 Example of Input/Output Signal Wiring

■ Example of Digital Input Signal Wiring

⚠ Caution

1. Input contact point can be set at Contact Point A or B, depending on the characteristics of each signal.
2. Each input contact point can be allotted to 28 functions.
3. Please see 「10.2 Input/Output Signals Setting」 for signal allotment and contact point change of input contact points.
4. The service rating is DC12V~ DC 24V.

Servo Drive

Inner Circuit

Inner Circuit

R1 : 3.3K Ω , R2 : 680 Ω

■ Example of Digital Output Signal Wiring

⚠ Caution

1. Input contact point can be set at Contact Point A or B, depending on the characteristics of each signal.
2. Each input contact point can be allotted to 19 functions.
3. Please see 「10.2 Input/Output Signals Setting」 for signal allotment and contact point change of input contact points.
4. As transistor switches are used, over voltages/current may cause damage. Please exercise caution.
5. The service rating is DC 24V \pm 10%, 120[mA].

Servo Drive

Inner
Circuit

Inner
Circuit

Note 1) For output signals DO1~ DO8, GND24 terminal is disconnected GND24.

■ Example of Analog Input Signal Wiring

⚠ Caution

1. Please see 「4.5 Analog Speed Override」 and 「10.8 Torque Limit Function 」 for operation of analog input signals.
2. The window if analog input signal is -10V ~ 10V.
3. Impedence of the input signals is appr. 22KΩ.

Servo Drive

(servoDrive: Servo Drive)

4. Example of Resistance Selection

No	R1	R2
1	5KΩ	6KΩ
2	10KΩ	12KΩ

■ Example of Analog Output Signal Wiring

⚠ Caution

5. Please see 「11.4 Analog Monitor」 for setting and scale adjustment of monitoring signals.
6. The window of analog output signal is -10V ~ 10V.
7. The resolution of analog output signals is 12bit.
8. The permissible maximum load current is 2.5[mA] or below.
9. The stabilization time is 15[us].

Servo Drive

(servoDrive:Servo Drive)

2.5.6 Pulse Train Input Signal

Line Drive (5[V]) Pulse Input

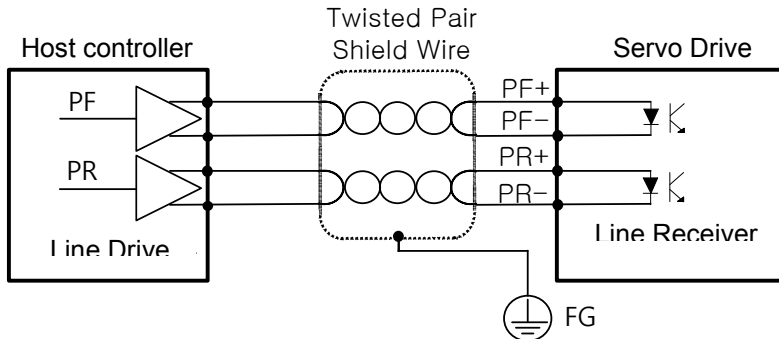

Open Collector (24[V]) Pulse Input

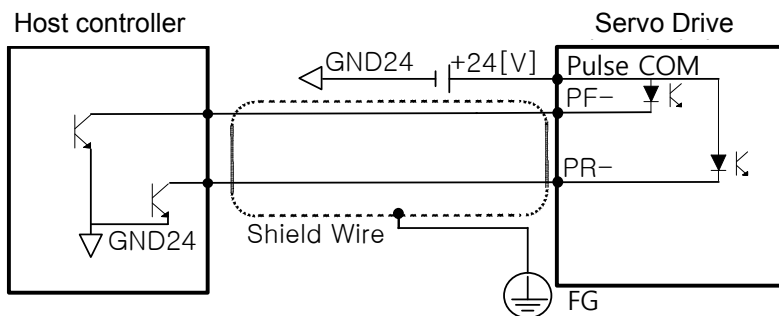

12[V] or 5[V] NPN Open Collector Pulse Command

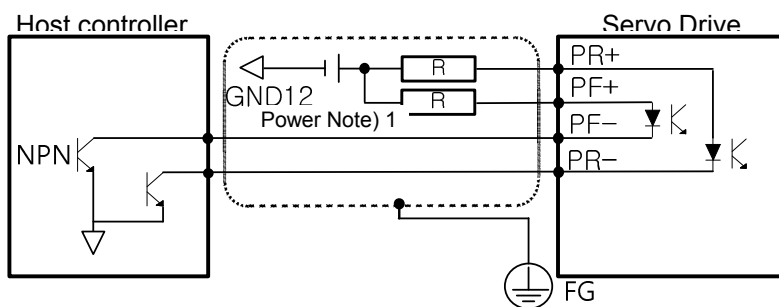

Note 1) When using 5[V] power: resistance $R=100\sim150[\Omega]$, $1/2[W]$

When using 12[V] power: resistance $R=560\sim680[\Omega]$, $1/2[W]$

When using 24[V] power: resistance $R=1.5[k\Omega]$, $1/2[W]$

2.5.7 Input/Output Signal Wiring

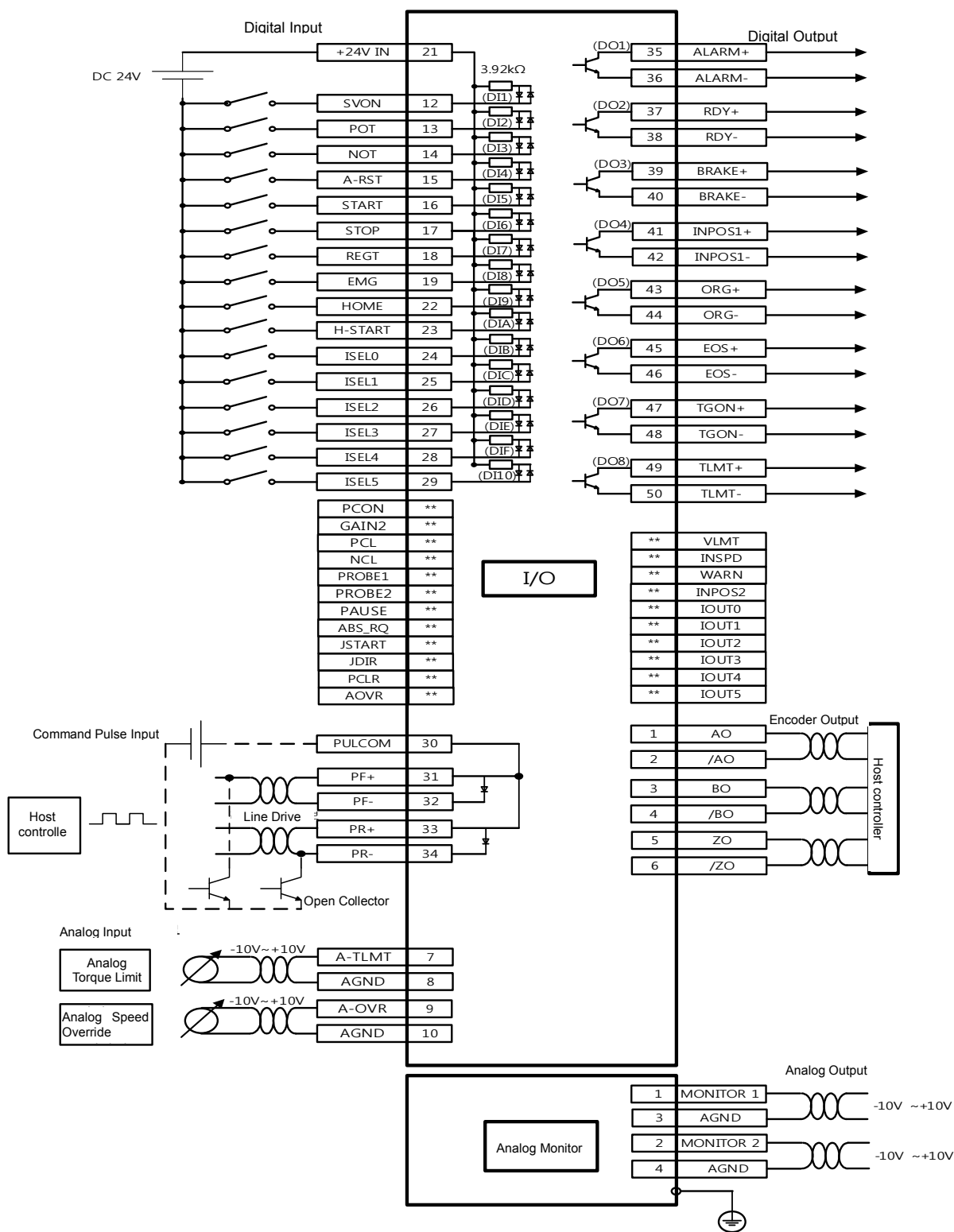

Input signals DI1~DI10 and output signals DO1~DO8 are the signals allotted at the time of being released from the factory.

Note) Digital output DO06, DP07 cannot be used as other functions when they are set encoder output mode[0x3007] as line drive and open collector.

2.6 Encoder Signal Unit (Connector) Wiring

ENCODER Connector Specifications: 10114-3000VE (3M)

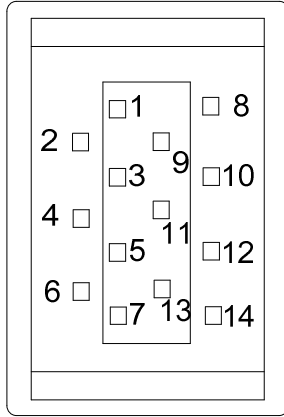

2.6.1 Option Specifications Connection Example

APCS-E ASCable (Quadrature Type)

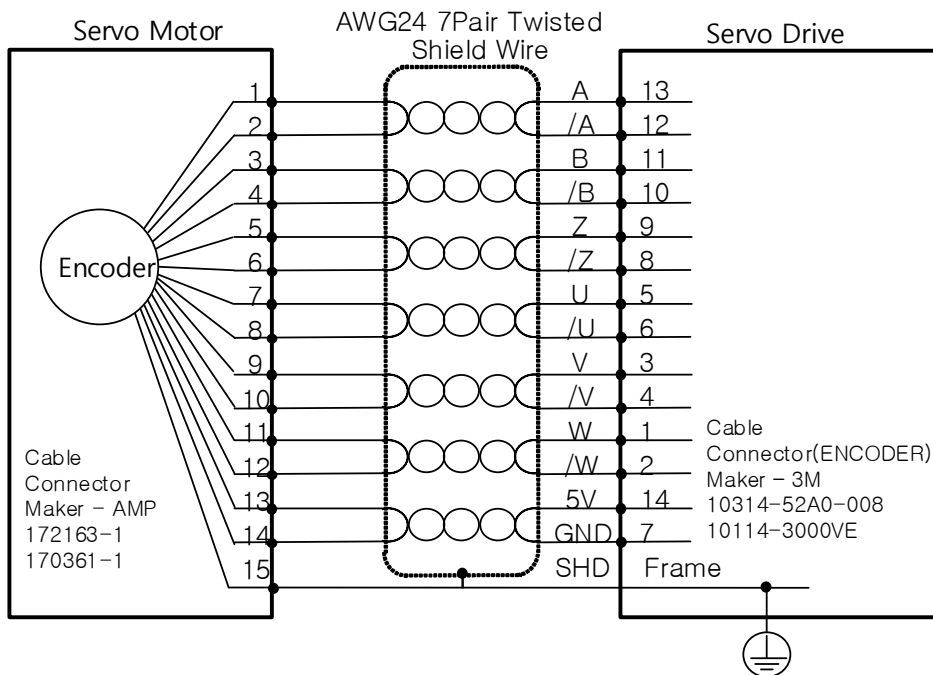

■ APCS-E BSCable (Quadrature Type)

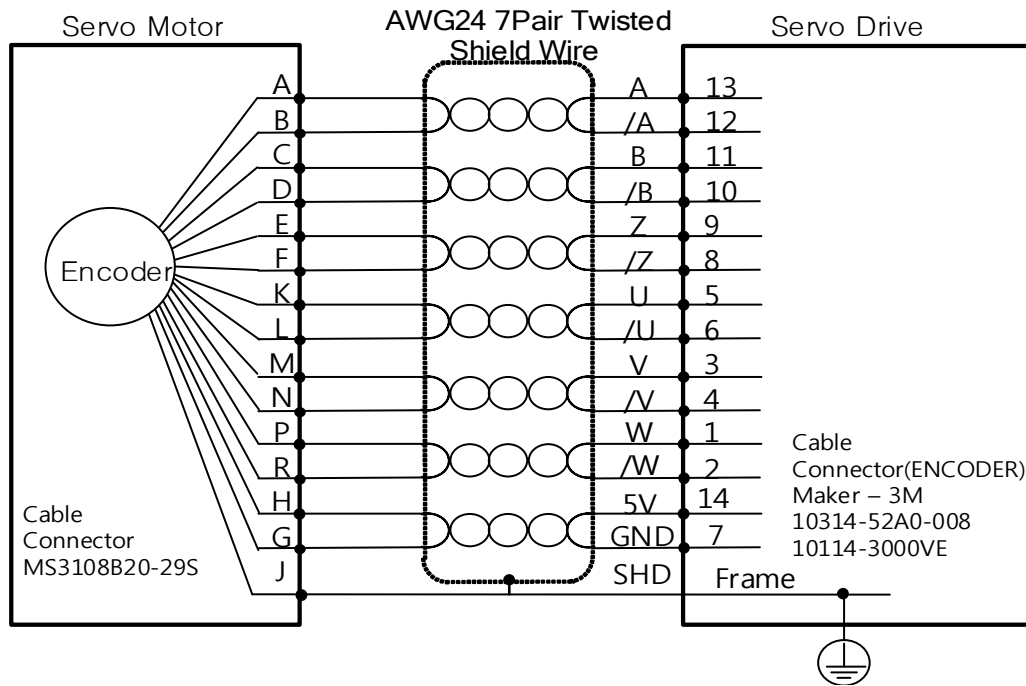

■ APCS-E CSCable (Serial-singleturn Type)

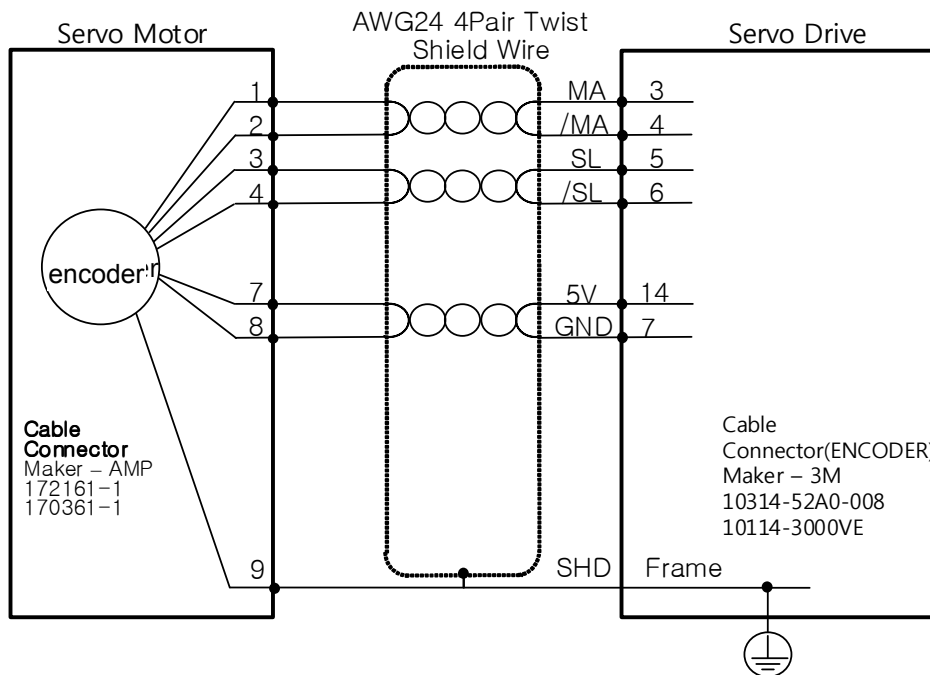

■ APCS-E DSCable (Serial-singleturn Type)

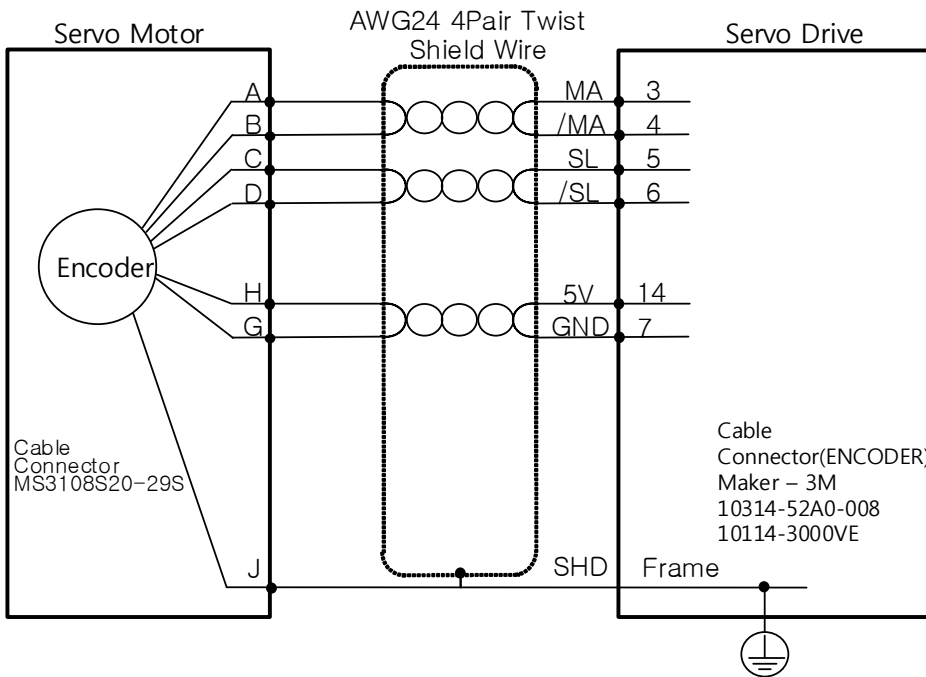

■ APCS-E ESCable (Serial-singleturn Type)

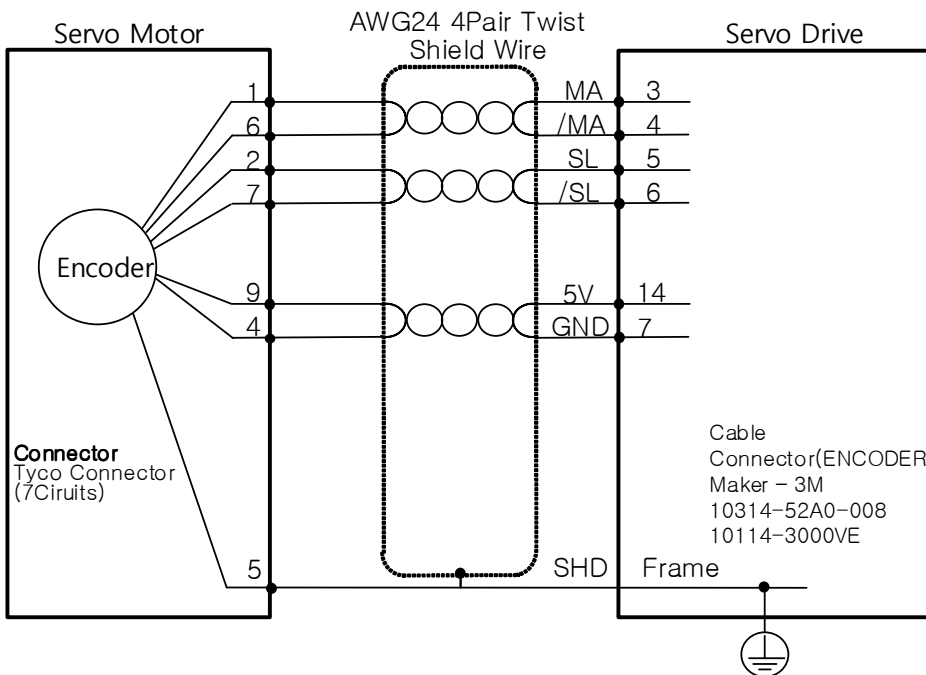

■ APCS-E CS1Cable (Serial-Multiturn Type)

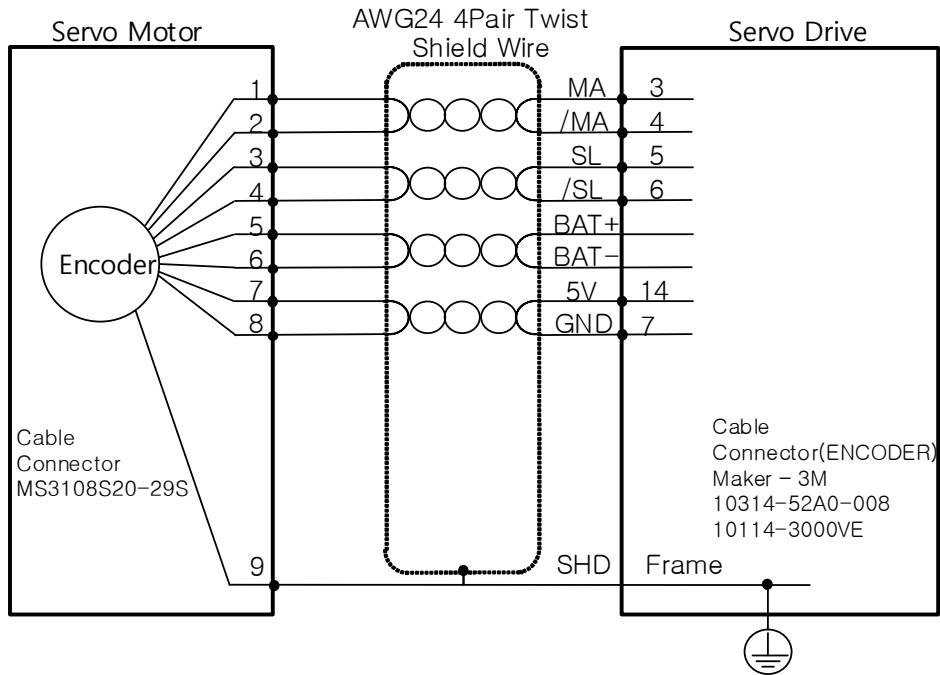

■ APCS-E DS1Cable (Serial-Multiturn Type)

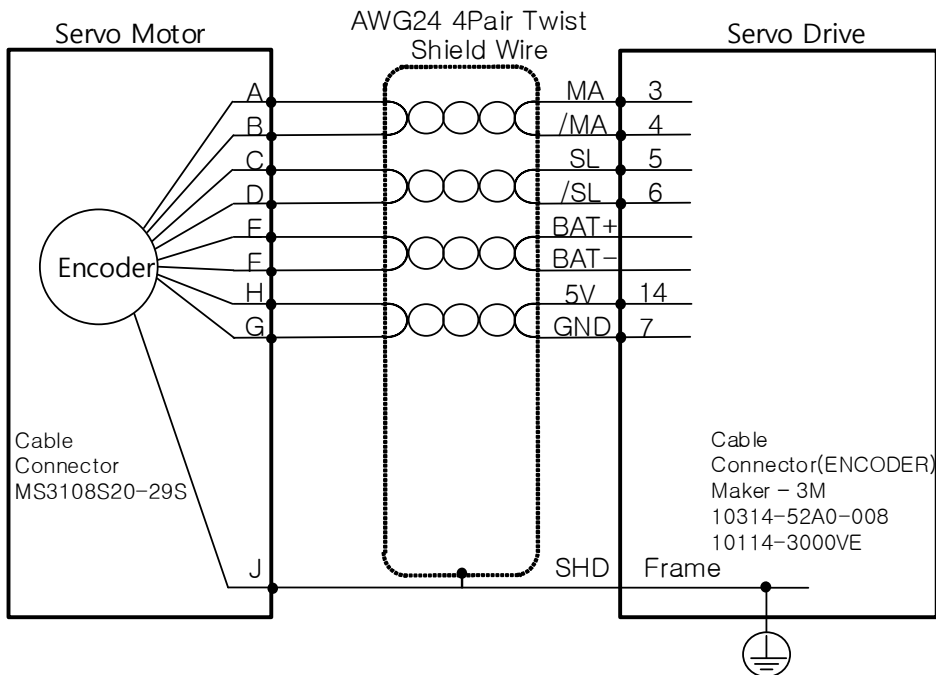

■ APCS-E ES1Cable (Serial-Multiturn Type)

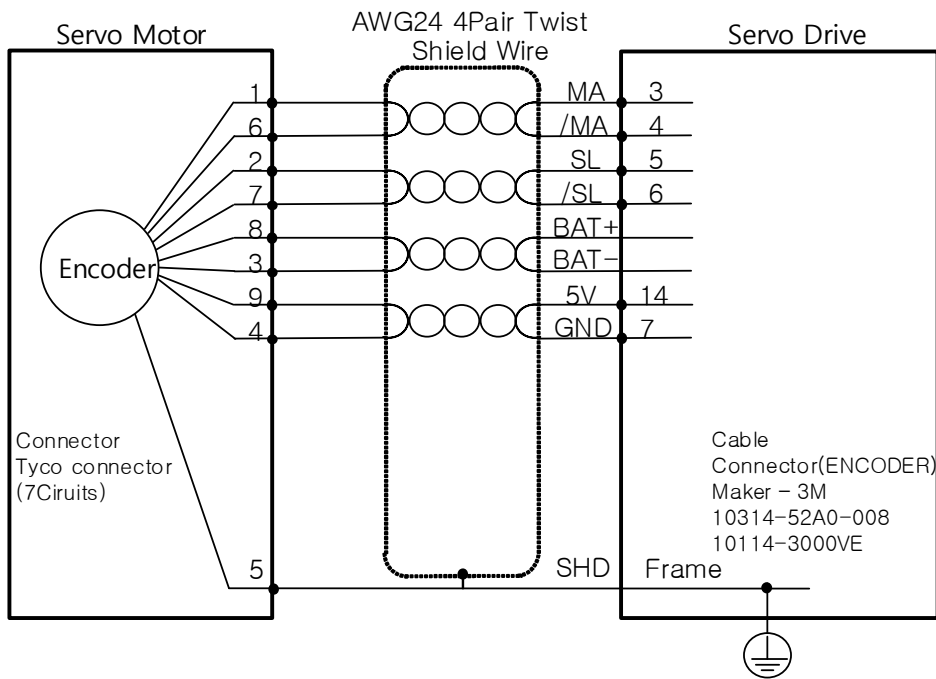

2.6.2 Linear Scale and Third party Encoder Connection Example

■ Wiring when Tamagawa Encoder(17bit incremental) is Applied

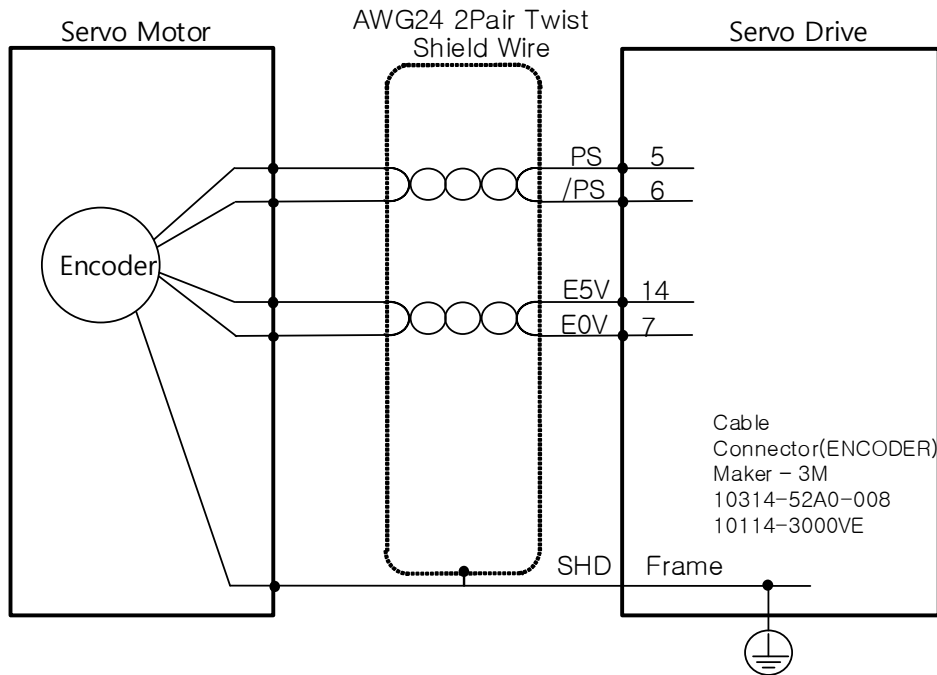

■ Wiring when EnDat 2.2 Encoder is Applied

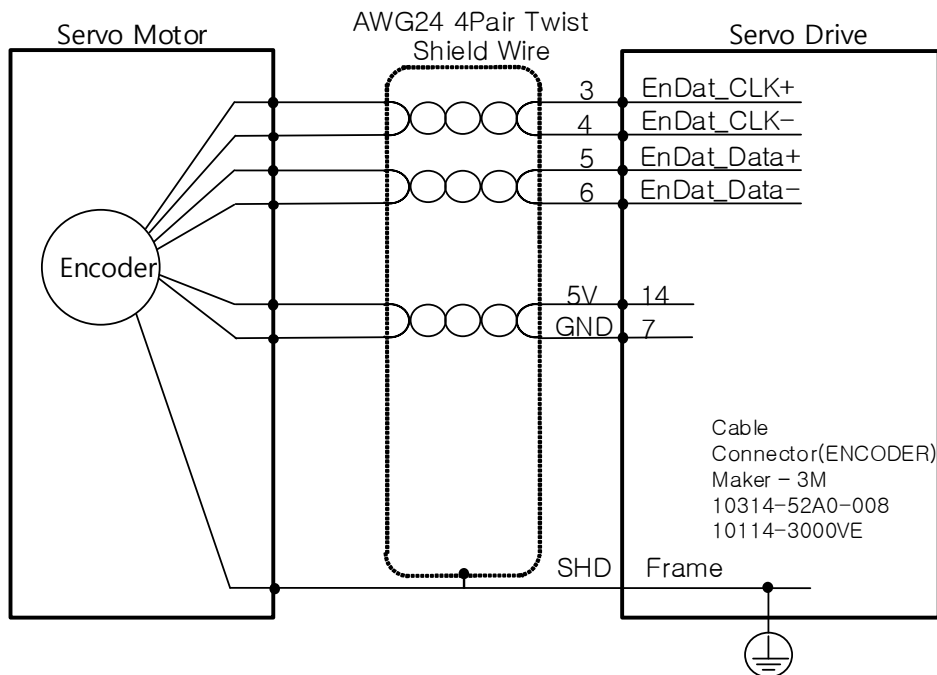

■ Quadrature Type without hall sensor

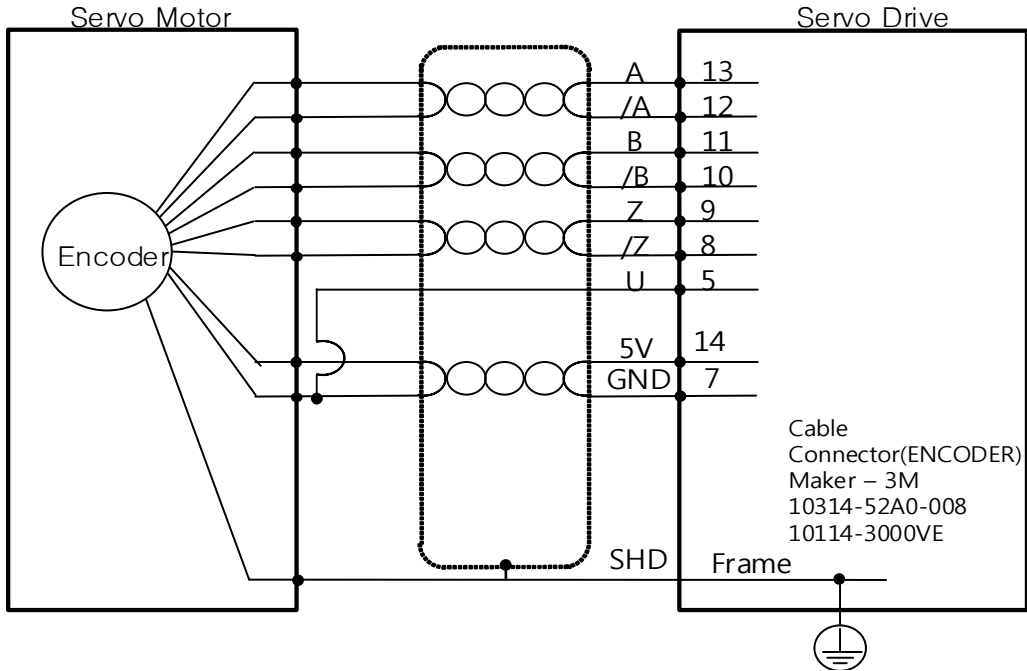

3. L7P Indexer Overview

3.1 Control Methods

L7Pdrive supports Indexing Position method and Pulse Input Position modes. The former internally generates and controls position command to determine position, and the latter receives pulse trains from outside and controls them.

Also, L7P drive supports Verocity control mode to control velocity by analog voltage and digital velocity using servo drive parameter, torque control mode to control torque by analog voltage

3.2 Indexing Position Operation

Indexing Position mode is a position control mode that internally generates position profiles without external Host controller. To use index function, set the control mode (0x3000)to 'Index Mode.'

The block diagram of the Indexing Position mode is as follows.

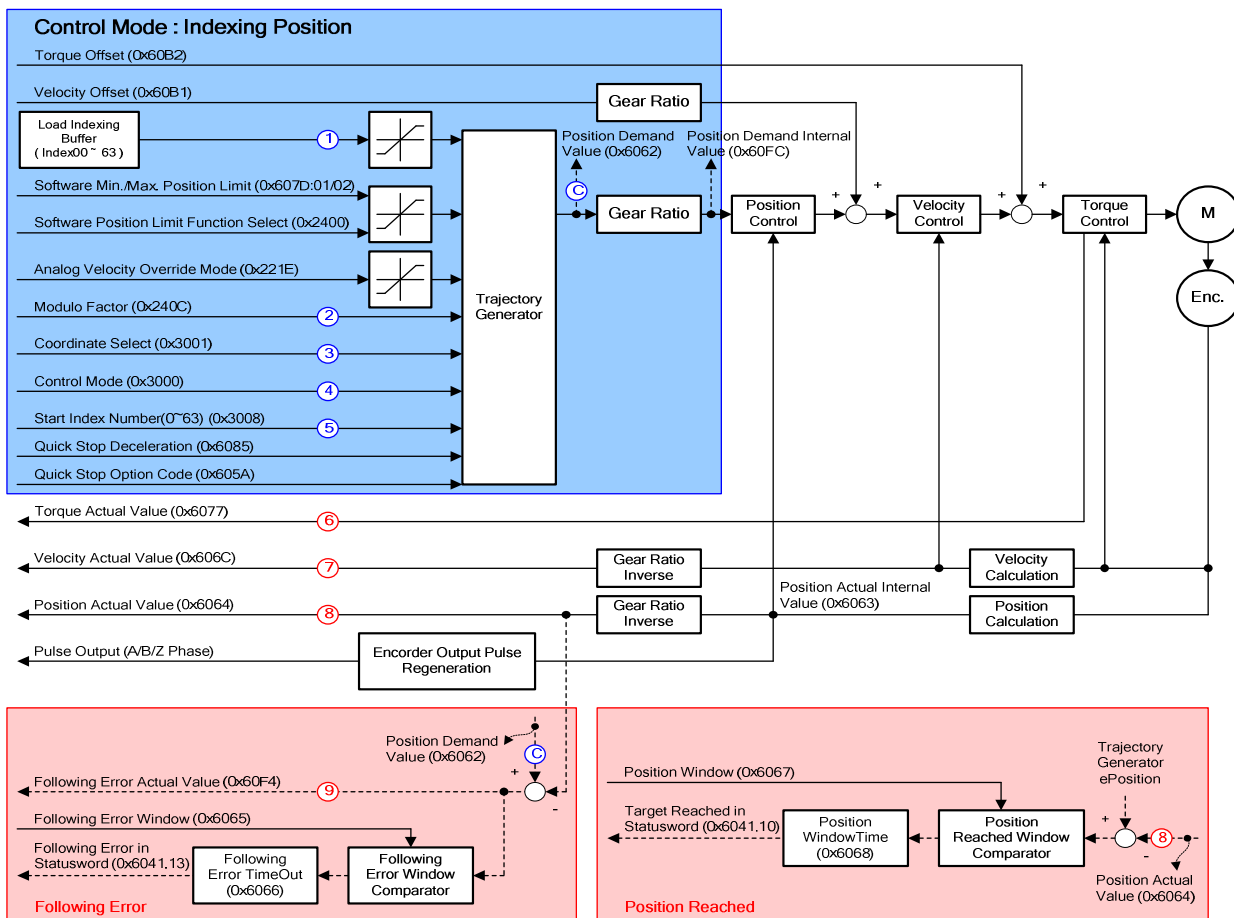

■ Related Objects

Index	Sub Index	Name	Format	Accessibility	PDO Allotment	Unit
0x6041	-	Statusword	UINT	RO	Yes	-
0x6062	-	Position Demand Value	DINT	RO	Yes	UU
0x60FC	-	Position Demand Internal Value	DINT	RO	Yes	pulse
0x6063	-	Position Actual Internal Value	DINT	RO	Yes	pulse
0x6064	-	Position Actual Value	DINT	RO	Yes	UU
0x607D	-	Software Position Limit	-	-	-	-
	0	Number of entries	USINT	RO	No	-
	1	Min position limit	DINT	RW	No	UU
	2	Max position limit	DINT	RW	No	UU
0x6085	-	Quick Stop Deceleration	UDINT	RW	No	UU/s ²
0x605A	-	Quick Stop Option Code	INT	RW	No	-
0x60B1	-	Speed Offset	DINT	RW	Yes	UU/s
0x60B2	-	Torque Offset	INT	RW	Yes	0.1%
0x606C	-	Speed Actual Value	DINT	RO	Yes	UU/s
0x6077	-	Torque Actual Value	INT	RO	Yes	0.1%
0x6065	-	Following Error Window	UDINT	RW	No	UU
0x6066	-	Following Error Timeout	UINT	RW	No	ms
0x6067	-	Position Window	UDINT	RW	No	UU
0x6068	-	Position Window Time	UINT	RW	No	ms
0x6091	-	Gear Ratio	-	-	-	-
	0	Number of entries	USINT	RO	No	-
	1	Motor Revolutions	UDINT	RW	No	-
	2	Shaft Revolutions	UDINT	RW	No	-
0x240C	-	Modulo Factor	DINT	RW	No	UU
0x3000	-	Control Mode	UINT	RW	No	-
0x3001	-	Coordinate Select	UINT	RW	No	-
0x3002	-	Baud Rate Select	UINT	RW	No	-

0x3006	-	Encoder Output Pulse	UDINT	RW	No	Pulse
0x3007	-	Encoder Output Mode	UINT	RW	No	
0x3008	-	Start Index Number(0~63)	UINT	RW	No	-
0x3100	-	Index 00	-	-	-	-
	0	Number of entries	USINT	RO	No	-
	1	Index Type	UINT	RW	No	-
	2	Distance	DINT	RW	No	UU
	3	Speed	DINT	RW	No	UU/s
	4	Acceleration	DINT	RW	No	UU/s ²
	5	Deceleration	DINT	RW	No	UU/s ²
	6	Registration Distance	DINT	RW	No	UU
	7	Registration Speed	DINT	RW	No	UU/s
	8	Repeat Count	UINT	RW	No	-
	9	Dwell Time	UINT	RW	No	ms
	10	Next Index	UINT	RW	No	-
11	Action	UINT	RW	No	-	
~		~				
0x313F	-	Index 63	-	-	-	-
0x221C	-	Analog Torque Input(command/limit) Scale	UINT	RW	Yes	0.1%/V
0x221D	-	Analog Torque Input(command/limit) Offset	INT	RW	Yes	mV
0x221E	-	Analog Speed Override Mode	UINT	RW	Yes	-
0x221F	-	Analog Speed Override Offset	INT	RW	Yes	mV

Internal Blocks of Indexing Position Mode

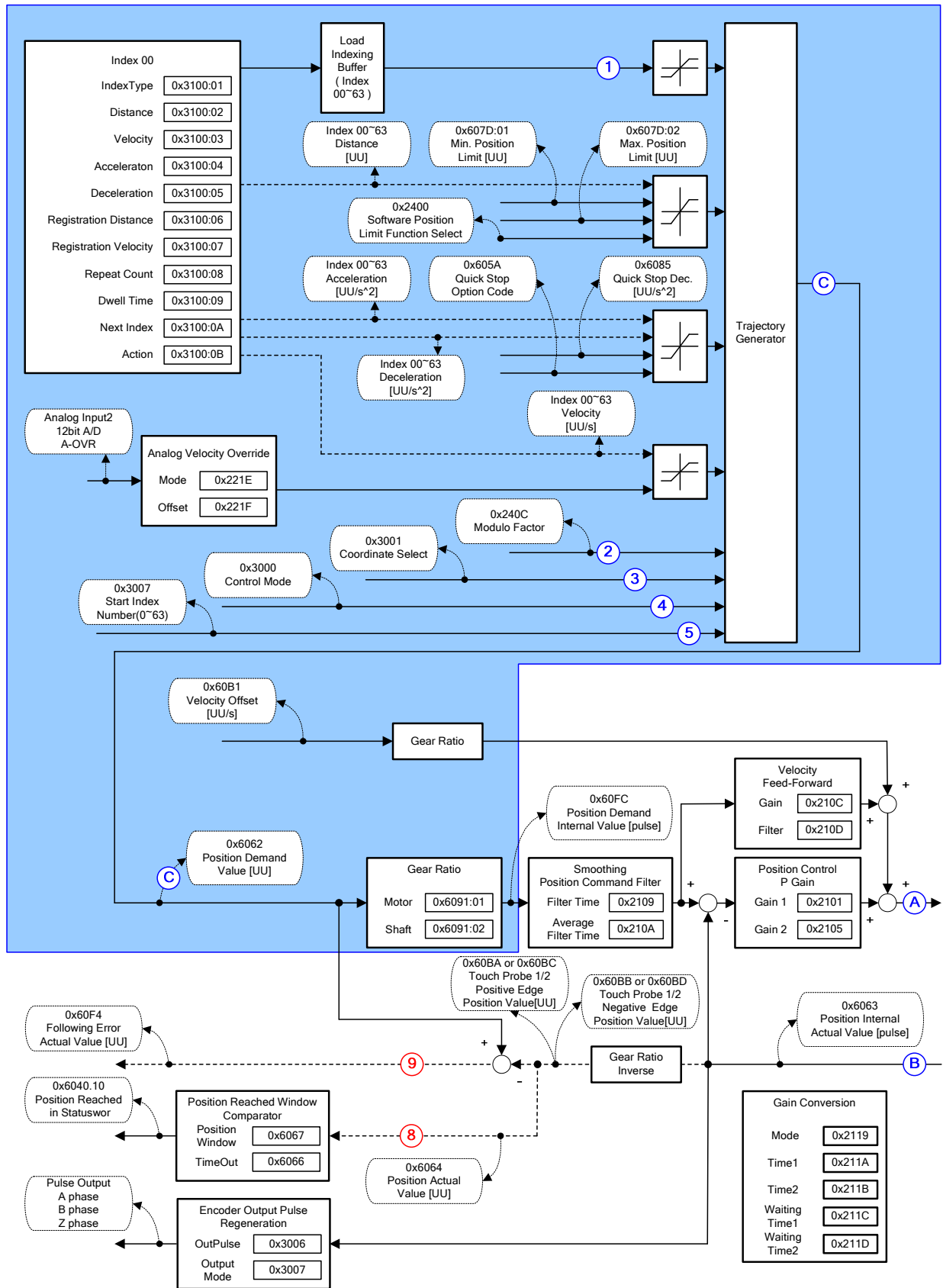

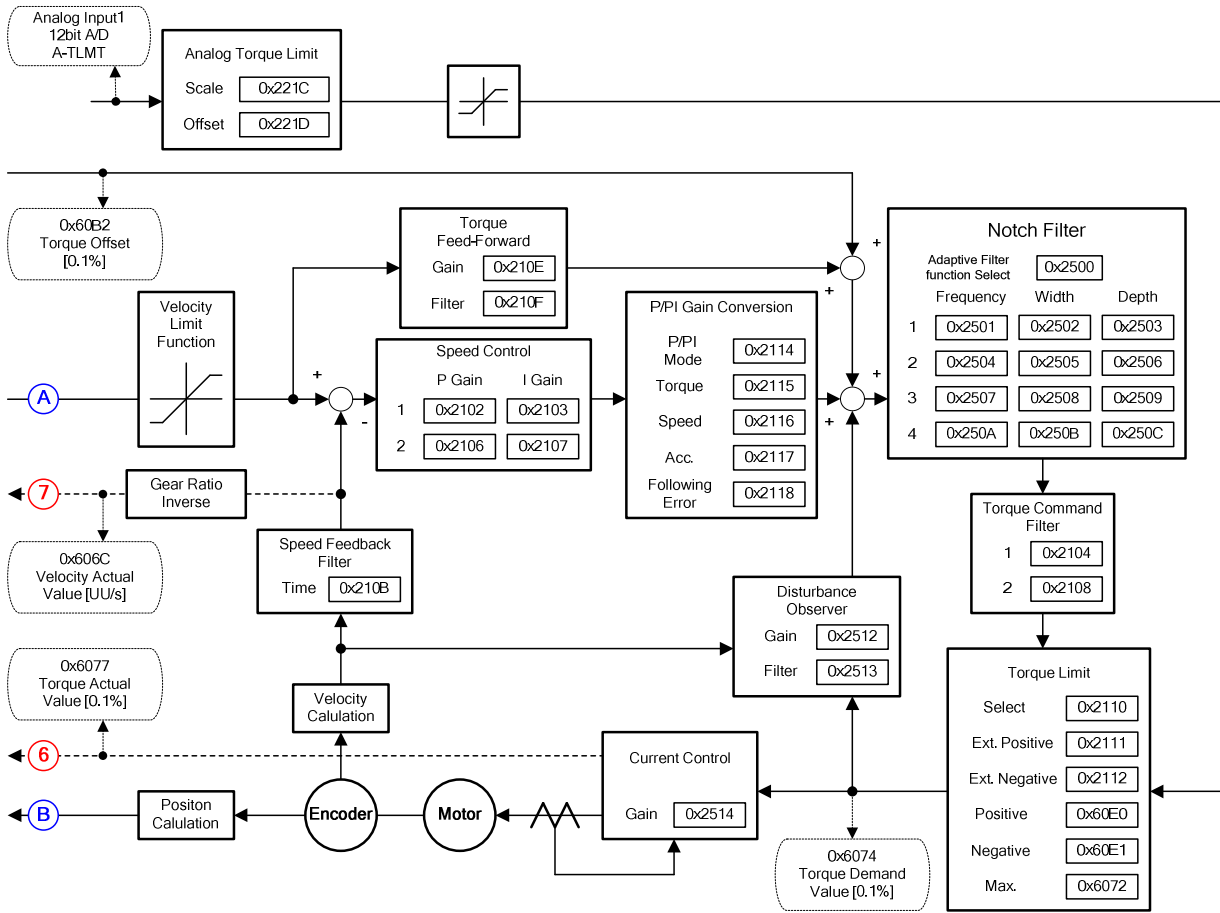

3.2.1 Coordinate Setting

Under the indexing mode, the two coordinate methods below can be used.

■ Linear Coordinate Method

Linear coordinate expresses the position value within the range from -2147483648 to $+2147483647$. If the value exceeds $+2147483647$ when rotating forward, the lowest value (-2147483648) is displayed. If the value exceeds -2147483648 when rotating reverses, the highest value ($+2147483647$) is displayed.

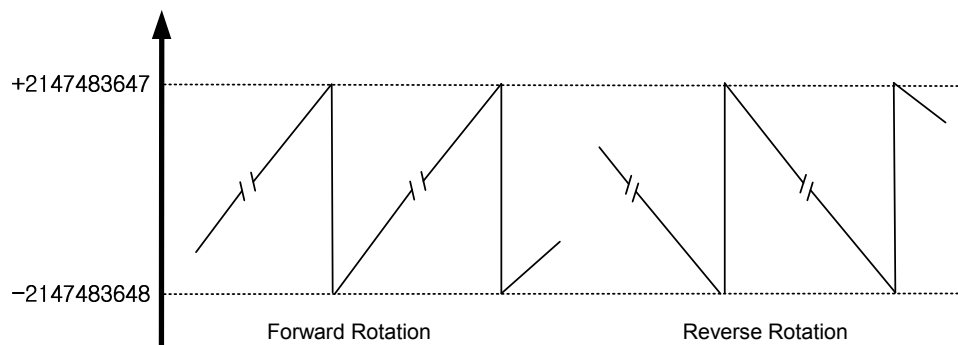

The control mode (0x3000) must be set to linear coordinate when performing the 6 PTP position controls below.

- Absolute Move

The final moving distance under the absolute move mode is the difference between the current position and the target distance.

- Relative Move

The final moving distance under the relative move mode is the target distance.

- Registration Absolute Move

The speed and distance changes to the registration speed and speed by the REGT signal input from outside during operation to the target position: the target position (absolute value) changes to the new target position during operation to the existing target position.

- Registration Relative Move

- The speed and distance changes to the registration speed and speed by the REGT signal input from outside during operation to the target position: the target position (relative value) changes to the new target position during operation to the existing target position.

- Blending Absolute Move

When receiving a new position command during operation to the target position, the operation to the new target position (absolute value) begins after reaching the original position

- Blending Relative Move

- When receiving a new position command during operation to the target position, the operation to the new target position (relative value) begins after reaching the original position

■ Rotary Coordinate Method

The rotary coordinate expresses position values only in positive values. The expressed range depends on the set value of the modulo factor, within the range of 0 ~ (Modulo Factor-1).

If the value exceeds (Modulo Factor-1) during forward rotation, the lowest value (0) is displayed. If the value exceeds 0 during reverse rotation, the lowest value (Modulo Factor-1) is displayed.

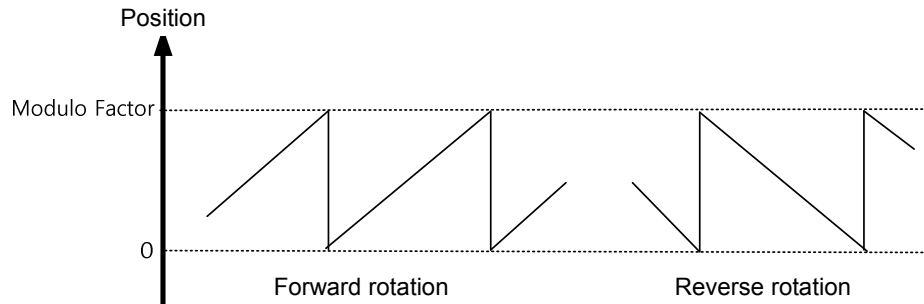

The control mode (0x3000) must be set to rotary coordinate when performing the 5 PTP position controls below, under the precondition that the Modulo Factor is set properly.

- Rotary Absolute Move

The direction is determined based on the relationship between the current position and the distance value. The direction is not necessarily determined based on shorter movement. Depending on the distance value, the motor rotates within one cycle (the value set at the Modulo Factor)

- Rotary Relative Move

Position operation is performed in the positive direction when the distance value is +, in the negative direction when the distance value is -. Depending on the distance value, the motor may rotate more than one cycle (the value set at the Modulo Factor)

- Rotary Shortest Move

The direction is determined based on the shorter distance from the current position. Depending on the distance value, the motor rotates within one cycle (the value set at the Modulo Factor). The distance value is handled as absolute value.

- Rotary Positive Move

The motor is operated always in the + direction. Depending on the distance value, the motor rotates within one cycle (the value set at the Modulo Factor). The distance value is handled as absolute value.

- Rotary Negative Move

- The motor is operated always in the - direction. Depending on the distance value, the motor rotates within one cycle (the value set at the Modulo Factor). The distance value is handled as absolute value.

3.2.2 Index Structure

The index structure is composed as follows.

Item		Description
Index Type	Linear Coordinate	0 : Absolute Move
		1 : Relative Move
		2 : Registration Absolute Move
		3 : Registration Relative Move
		4 : Blending Absolute Move
	5 : Blending Relative Move	
	Rotary Coordinate	6 : Rotary Absolute Move
		7 : Rotary Relative Move
		8 : Rotary Shortest Move
		9 : Rotary Positive Move
10 : Rotary Negative Move		
Distance	-2147483648 ~ +2147483647 (Unit: UU')	
Speed	1 ~ 2147483647(Unit: UU/s)	
Acceleration	1 ~ 2147483647(Unit: UU/s ²)	
Deceleration	1 ~ 2147483647(Unit: UU/s ²)	
Registration Distance	-2147483648 ~ 2147483647(Unit: UU)	
Registration Speed	1 ~ 2147483647(Unit: UU/s)	
Repeat Count	1 ~ 65535	
Dwell Time	0 ~ 65535(Unit: ms)	
Next Index	0 ~ 63	
Action	0 : Stop 1 : Wait for Start 2 : Next Index	

*UU: User Unit

3.3 Pulse Input Position Operation

L7P Servodrive provides a mode that determines position using pulse train inputs from external controller. To use the pulse input position control mode, set the control mode (0x3000) to 'pulse input position control mode.'

The following is the block diagram for the pulse input position mode.

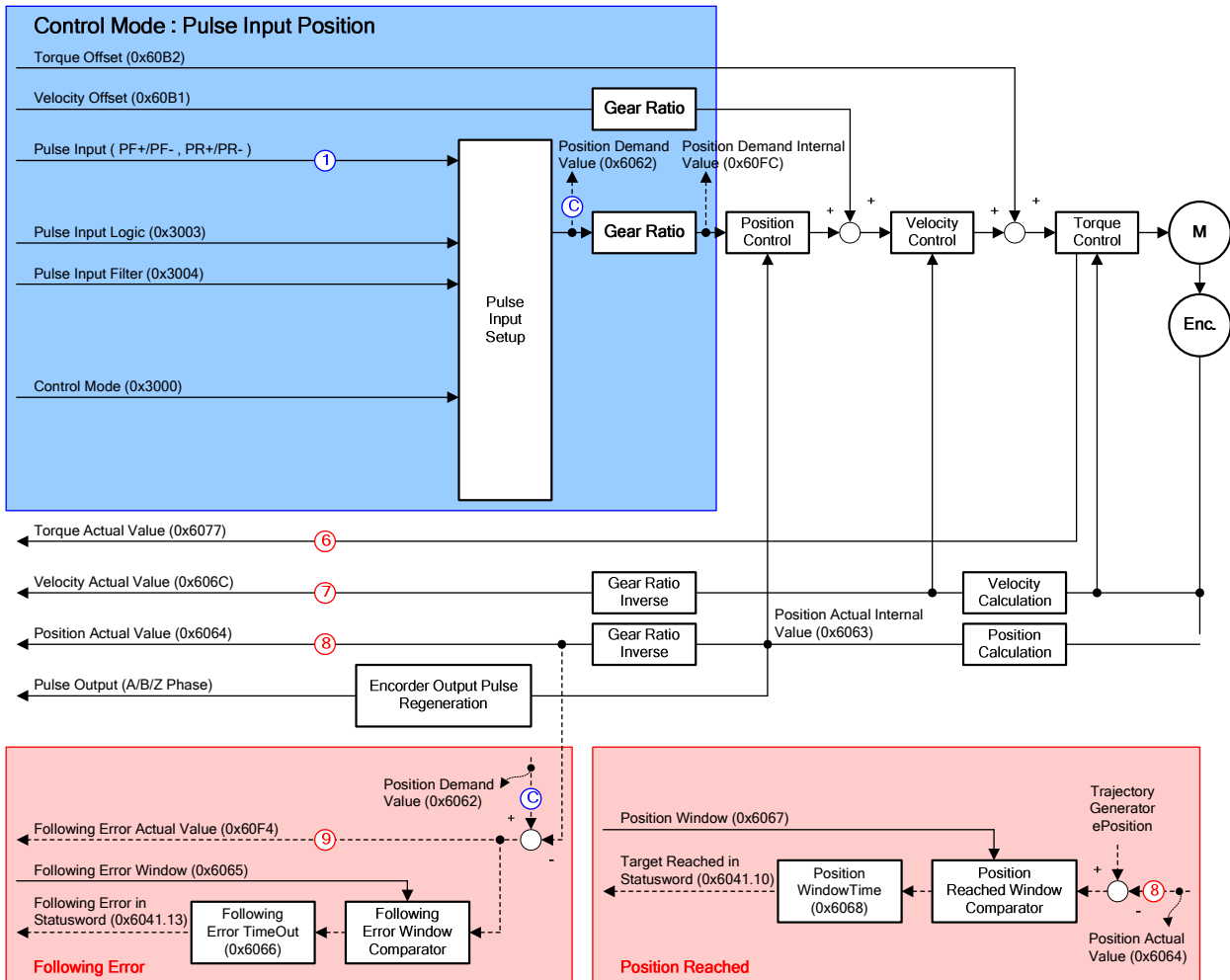

■ Related Objects

Index	Sub Index	Name	Variable Format	Accessibility	PDO Allotment	Unit
0x6041	-	Statusword	UINT	RO	Yes	-
0x6062	-	Position Demand Value	DINT	RO	Yes	UU
0x60FC	-	Position Demand Internal Value	DINT	RO	Yes	pulse
0x6063	-	Position Actual Internal Value	DINT	RO	Yes	pulse
0x6064	-	Position Actual Value	DINT	RO	Yes	UU
0x60B1	-	Speed Offset	DINT	RW	Yes	UU/s
0x60B2	-	Torque Offset	INT	RW	Yes	0.1%
0x606C	-	Speed Actual Value	DINT	RO	Yes	UU/s
0x6077	-	Torque Actual Value	INT	RO	Yes	0.1%
0x6065	-	Following Error Window	UDINT	RW	No	UU
0x6066	-	Following Error Timeout	UINT	RW	No	ms
0x6067	-	Position Window	UDINT	RW	No	UU
0x6068	-	Position Window Time	UINT	RW	No	ms
0x6091	-	Gear Ratio	-	-	-	-
	0	Number of entries	USINT	RO	No	-
	1	Motor Revolutions	UDINT	RW	No	-
	2	Shaft Revolutions	UDINT	RW	No	-
0x240C	-	Modulo Factor	DINT	RW	No	UU
0x3000	-	Control Mode	UINT	RW	No	-
0x3001	-	Coordinate Select	UINT	RW	No	-
0x3002	-	Baud Rate Select	UINT	RW	No	-
0x3003	-	Pulse Input Logic Select	UINT	RW	No	-
0x3004	-	Pulse Input Filter Select	UINT	RW	No	-
0x3005	-	PCLEAR Mode Select	UINT	RW	No	-
0x3006	-	Encoder Output Pulse	UDINT	RW	No	Pulse
0x3007	-	Encoder Output Mode	UINT	RW	No	
0x3008	-	Start Index Number(0~63)	UINT	RW	No	-

0x221C	-	Analog Torque Input(command/limit) Scale	UINT	RW	Yes	0.1%/V
0x221D	-	Analog Torque Input(command/limit) Offset	INT	RW	Yes	mV

Inner Block Diagram under the Pulse Input Position

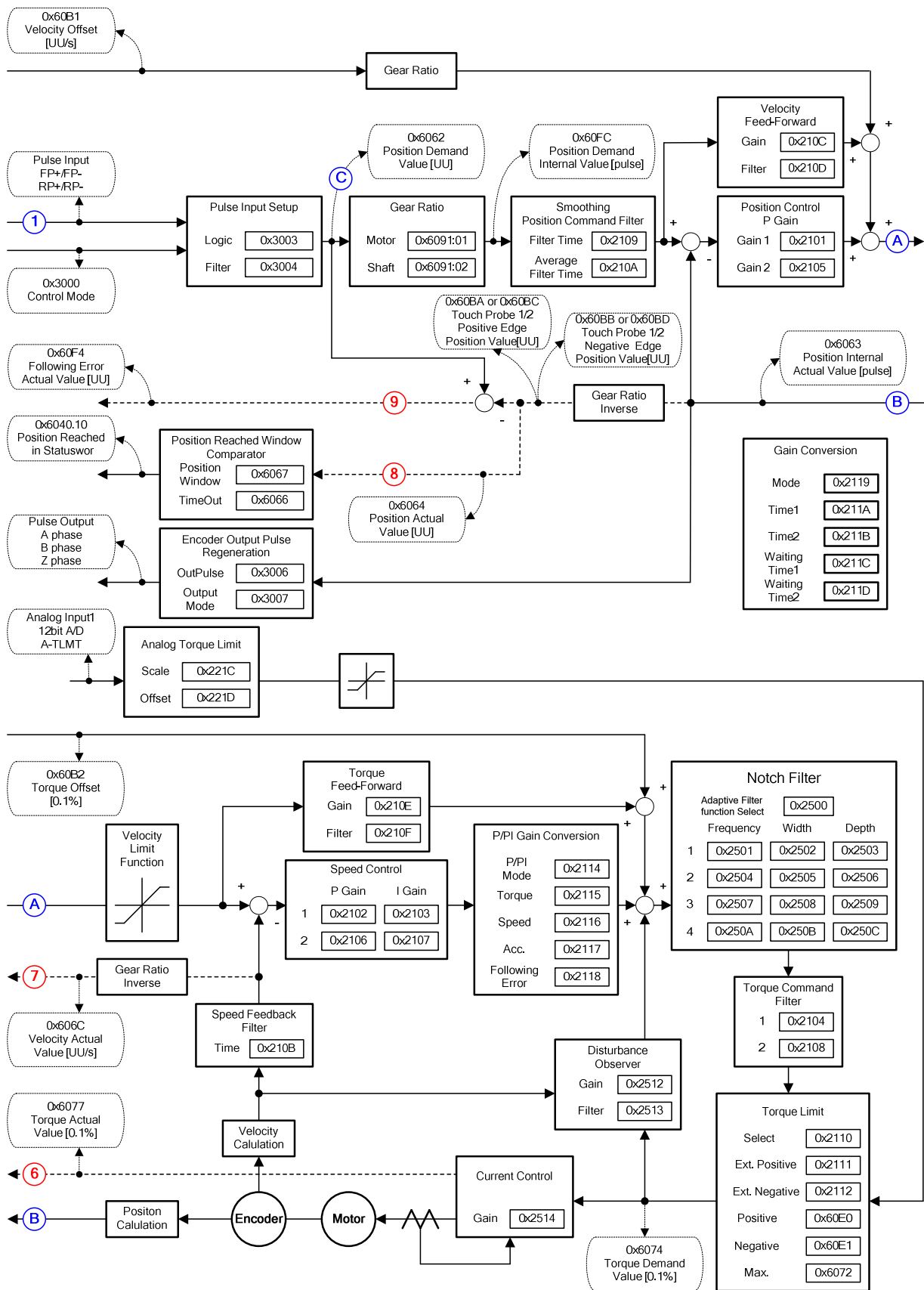

3.4 Velocity Control

The purpose of Velocity control mode is to control velocity by analog voltage from upper controller and digital velocity using servo drive parameter

After setting '2' in control mode[0x3000], choose the selection of speed command switch[0x231A] depending on command method to servo drive.

The Block diagram of velocity control mode is as below

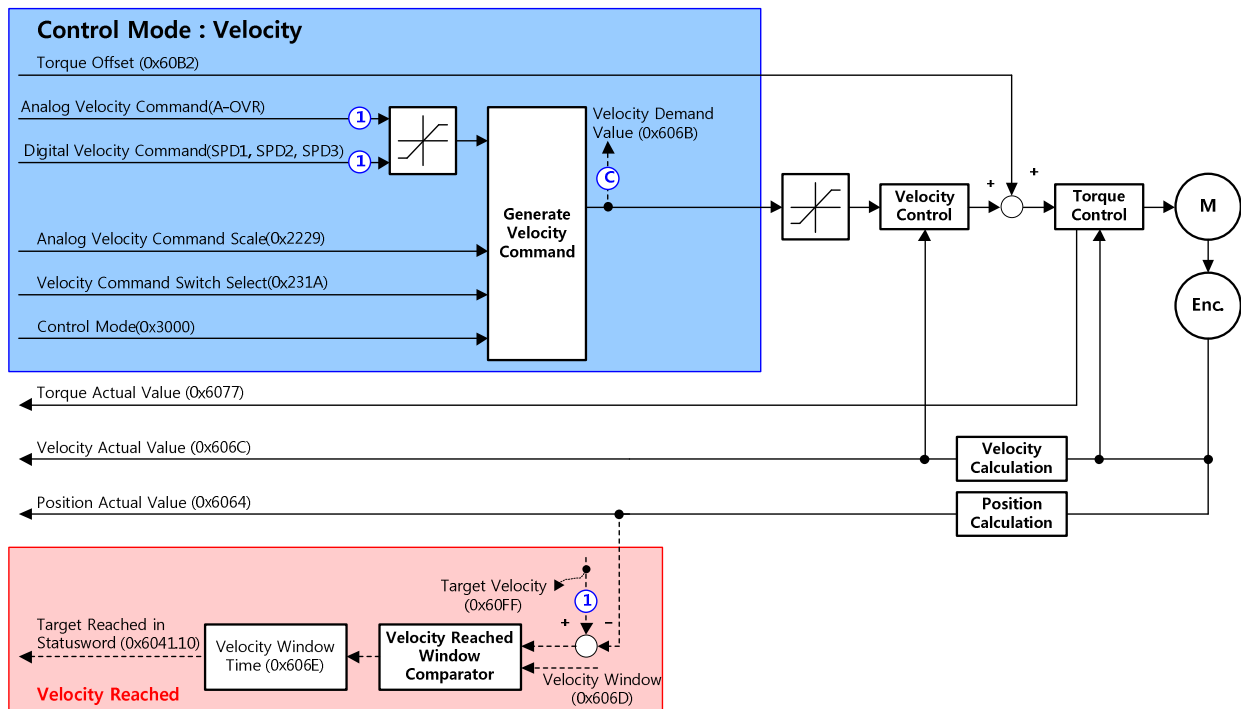

■ Related objects

Index	Sub Index	Name	Variable Format	Accessibility	PDO Allocation	Unit
0x2121	-	Drive Status Output1	UINT	RO	Yes	-
0x2122	-	Drive Status Output2	UINT	RO	Yes	-
0x6062	-	Position Demand Value	DINT	RO	Yes	UU
0x60FC	-	Position Demand Internal Value	DINT	RO	Yes	pulse
0x6063	-	Position Actual Internal Value	DINT	RO	Yes	pulse
0x6064	-	Position Actual Value	DINT	RO	Yes	UU
0x60B1	-	Velocity Offset	DINT	RW	Yes	UU/s
0x60B2	-	Torque Offset	INT	RW	Yes	0.1%
0x606C	-	Velocity Actual Value	DINT	RO	Yes	UU/s
0x6077	-	Torque Actual Value	INT	RO	Yes	0.1%
0x6065	-	Following Error Window	UDINT	RW	No	UU
0x6066	-	Following Error Timeout	UINT	RW	No	ms
0x6067	-	Position Window	UDINT	RW	No	UU
0x6068	-	Position Window Time	UINT	RW	No	ms
0x3000	-	Control Mode	UINT	RW	No	-
0x3002	-	Baud Rate Select	UINT	RW	No	-
0x3006	-	Encoder Output Pulse	UDINT	RW	No	Pulse
0x3007	-	Encoder Output Mode	UINT	RW	No	
0x221C	-	Analog Torque Input(command/limit) Scale	UINT	RW	Yes	0.1%/V
0x221D	-	Analog Torque Input(command/limit) Offset	INT	RW	Yes	mV
0x3007	-	Digital Input Signal 1 Selection	UINT	RW	No	-
0x2201	-	Digital Input Signal 2 Selection	UINT	RW	No	-
0x2202	-	Digital Input Signal 3 Selection	UINT	RW	No	-
0x2203	-	Digital Input Signal 4 Selection	UINT	RW	No	-
0x2204	-	Digital Input Signal 5 Selection	UINT	RW	No	-
0x2205	-	Digital Input Signal 6 Selection	UINT	RW	No	-
0x2206	-	Digital Input Signal 7 Selection	UINT	RW	No	-
0x2207	-	Digital Input Signal 8 Selection	UINT	RW	No	-

0x2208	-	Digital Input Signal 9 Selection	UINT	RW	No	-
0x2209	-	Digital Input Signal 10 Selection	UINT	RW	No	-
0x220A	-	Digital Input Signal 11 Selection	UINT	RW	No	-
0x220B	-	Digital Input Signal 12 Selection	UINT	RW	No	-
0x220C	-	Digital Input Signal 13 Selection	UINT	RW	No	-
0x220D	-	Digital Input Signal 14 Selection	UINT	RW	No	-
0x220E	-	Digital Input Signal 15 Selection	UINT	RW	No	-
0x220F	-	Digital Input Signal 16 Selection	UINT	RW	No	-
0x2312	-	Multi-Step Operation Speed 1	INT	RW	No	-
0x2313	-	Multi-Step Operation Speed 2	INT	RW	No	-
0x2314	-	Multi-Step Operation Speed 3	INT	RW	No	-
0x2315	-	Multi-Step Operation Speed 4	INT	RW	No	-
0x2316	-	Multi-Step Operation Speed 5	INT	RW	No	-
0x2317	-	Multi-Step Operation Speed 6	INT	RW	No	-
0x2318	-	Multi-Step Operation Speed 7	INT	RW	No	-
0x2319	-	Multi-Step Operation Speed 8	INT	RW	No	-
0x231A	-	Velocity Command Switch Select	UINT	RW	No	-
0x2227	-	Analog Velocity Command Filter Time Constant	UINT	RW	No	-
0x2229	-	Analog Velocity Command Scale	INT	RW	No	-
0x222A	-	Analog Velocity Command Clamp Level	UINT	RW	No	-

3.5 Torque Control

The purpose of torque control is to control such as tension or pressure of machine part by voltage desired torque from upper controller

Select '3' in the control mode[0x3000]

For command torque, Enter -10[V] ~ +10[V] voltage to no.7 and no.8 on I/O connector

The Block diagram of velocity control mode is as below

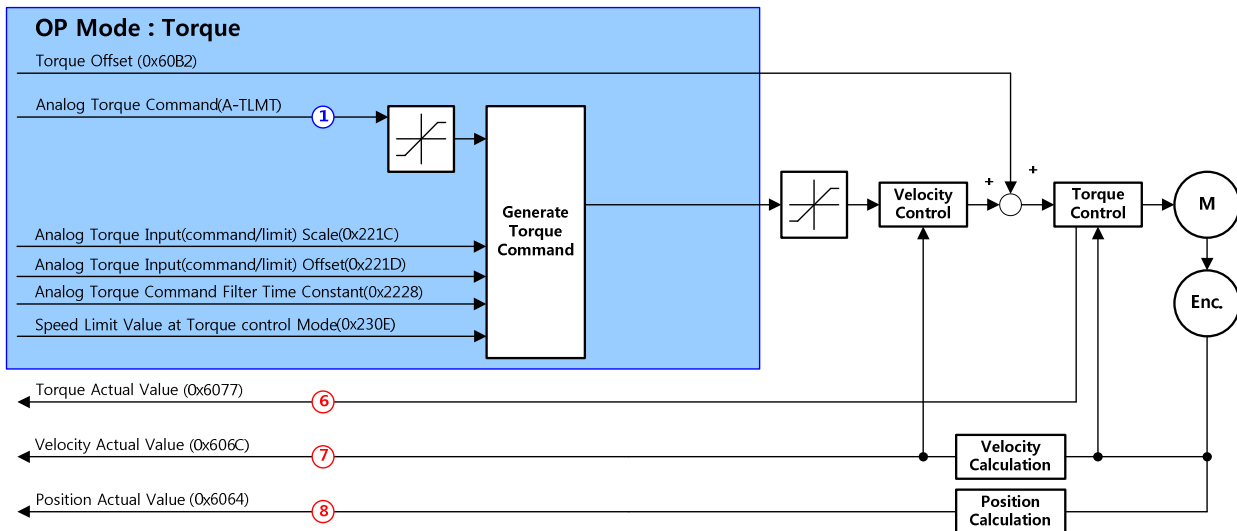

■ Related objects

Index	Sub Index	Name	Variable Format	Accessibility	PDO Allocation	Unit
0x2121	-	Drive Status Output1	UINT	RO	Yes	-
0x2122	-	Drive Status Output2	UINT	RO	Yes	-
0x6062	-	Position Demand Value	DINT	RO	Yes	UU
0x60FC	-	Position Demand Internal Value	DINT	RO	Yes	pulse
0x6063	-	Position Actual Internal Value	DINT	RO	Yes	pulse
0x6064	-	Position Actual Value	DINT	RO	Yes	UU
0x60B1	-	Velocity Offset	DINT	RW	Yes	UU/s
0x60B2	-	Torque Offset	INT	RW	Yes	0.1%
0x606C	-	Velocity Actual Value	DINT	RO	Yes	UU/s
0x6077	-	Torque Actual Value	INT	RO	Yes	0.1%
0x6065	-	Following Error Window	UDINT	RW	No	UU

0x6066	-	Following Error Timeout	UINT	RW	No	ms
0x6067	-	Position Window	UDINT	RW	No	UU
0x6068	-	Position Window Time	UINT	RW	No	ms
0x3000	-	Control Mode	UINT	RW	No	-
0x3002	-	Baud Rate Select	UINT	RW	No	-
0x3006	-	Encoder Output Pulse	UDINT	RW	No	Pulse
0x3007	-	Encoder Output Mode	UINT	RW	No	
0x221C	-	Analog Torque Input(command/limit) Scale	UINT	RW	No	-
0x221D	-	Analog Torque Input(command/limit) Offset	INT	RW	No	-
0x2228	-	Analog Torque Command Filter Time Constant	UINT	RW	No	-
0x230E	-	Speed Limit Value at Torque Control Mode	UINT	RW	No	-

■ The Block diagram of Torque control mode

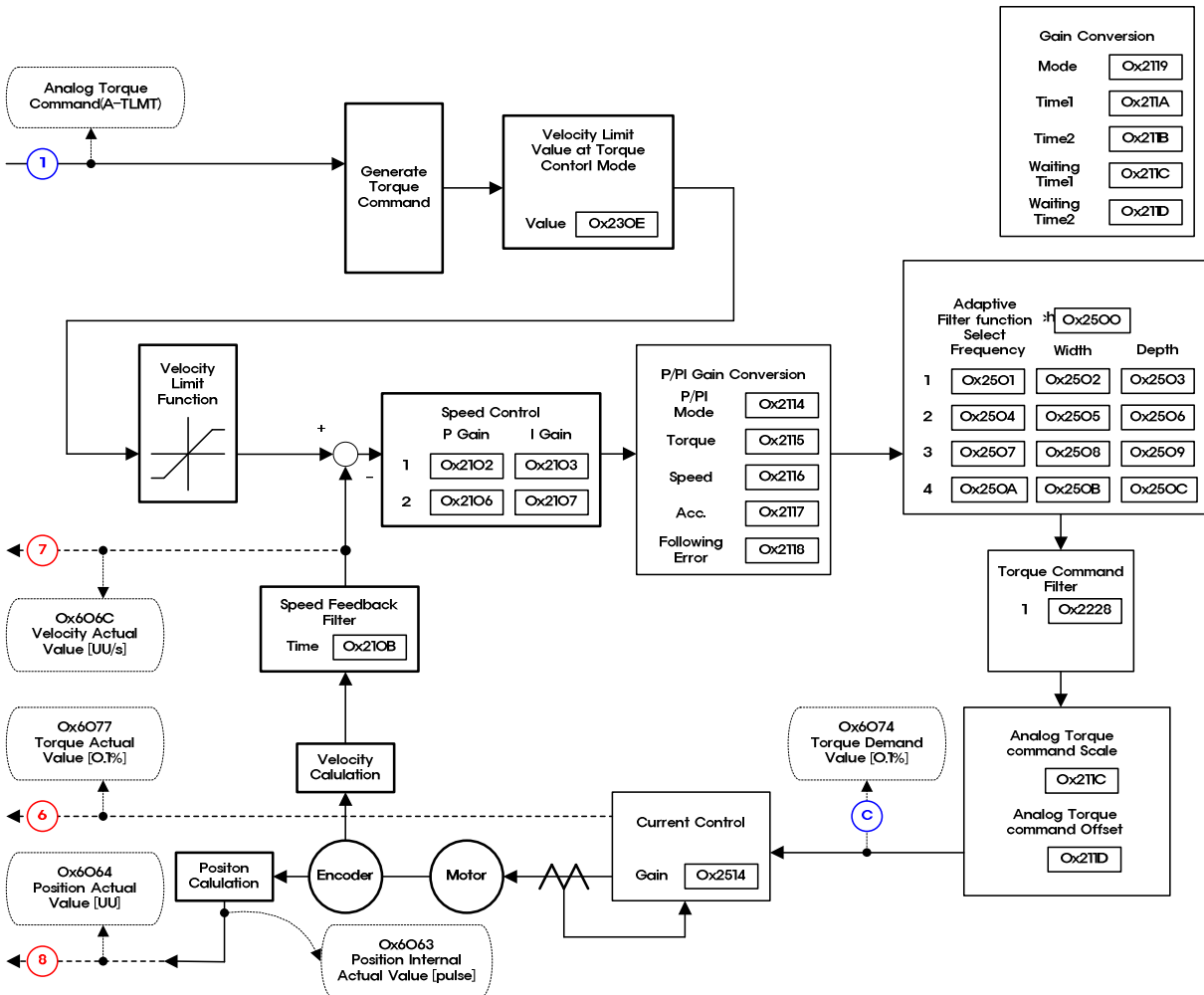

4. Indexing Position Operation

4.1 Concept of Index

An index consists of the following components: Distance, Speed, Acceleration, Deceleration, Registration Distance, Registration Speed, Repeat Count, Dwell Time, Next Index, Action. Below are descriptions of each of the components

■ Distance

Distance refers to the moving distance of each index (Unit: UU): it can be either absolute or relative.

The final distance for absolute movement is the difference between the moving distance and the current position. The final distance for relative movement is the movement distance.

The final moving distance is the size of the colored area under the acceleration/deceleration pattern below.

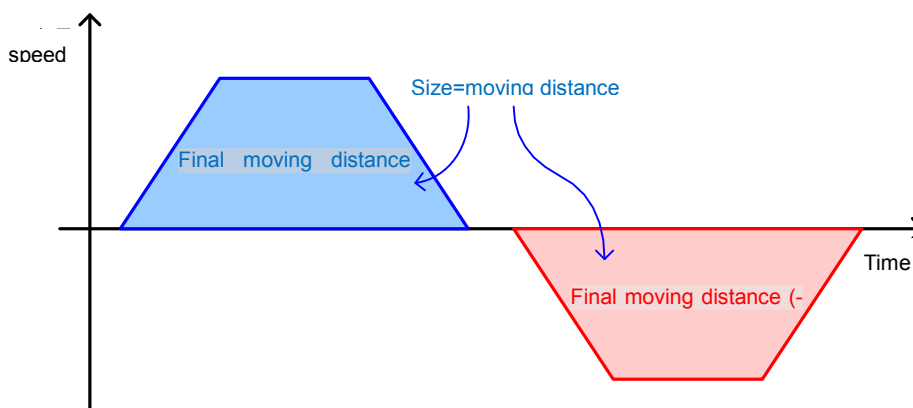

■ Speed

Speed determines the target speed for index operation (Unit: UU/s).

Speed always has positive value regardless of the movement distance. The positivity/negativity of the target speed is determined based on the positivity/negativity of the movement distance.

When the moving distance is not sufficient compared with the set value of speed and acceleration/deceleration, a triangular pattern may be generated, which means the speed failed to reach the target speed.

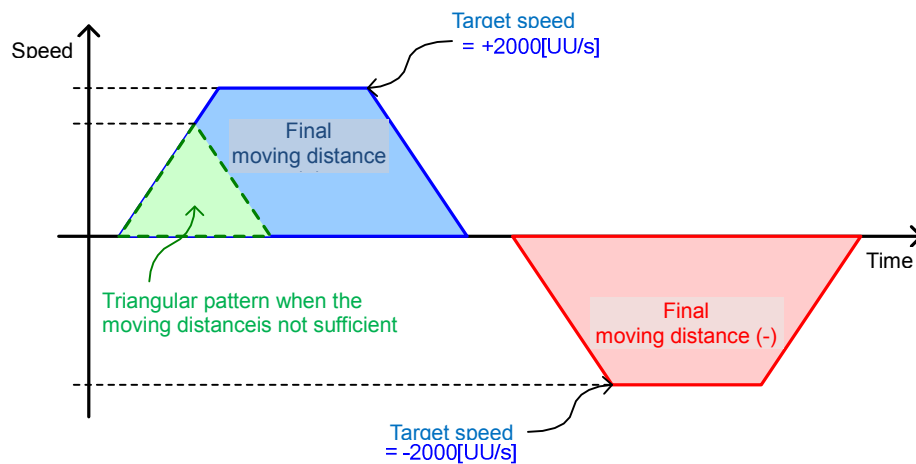

■ Acceleration, Deceleration

This sets the acceleration and deceleration when operating index. The product supports assymetrical acceleration/deceleration operation, where the acceleration and deceleration are different from each other.

As shown in the figure below, when Speed = 1000[UU/s], Acceleration = 10000[UU/s²], Deceleration = 20000[UU/s²], the time to accelerate to the target speed is 100[ms] (=1000[UU/s]/10000[UU/s²]), and the deceleration time is 50[ms] (= 1000[UU/s] /20000[UU/s²]).

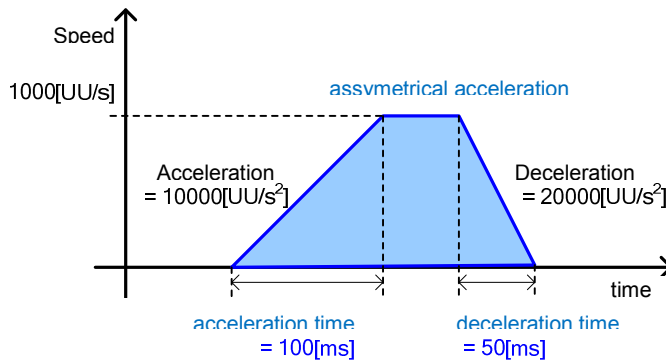

■ Registration Distance, Registration Speed

If the index type is Registration Absolute or Registration Relative, the operation speed and distance can be changed by REGT signal input from outside.

The distance after REGT signal input is determined by the Registration Distance.

The meaning of registration distance and registration speed is as follows.

- Registration Distance

Means the distance (Unit: UU) after the REGT signal input.

- Registration Speed

Means the target speed (Unit: UU/s) for movement after the REGT signal input.

The acceleration/deceleration when the speed changes due to registration, the acceleration/deceleration is based on the preset acceleration/deceleration.

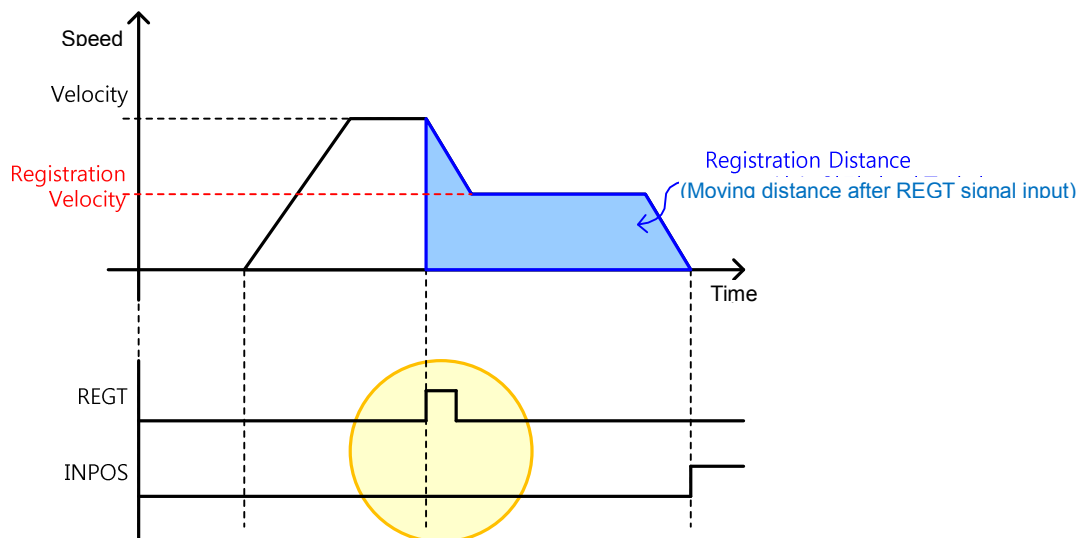

■ Repeat Count

The index is repeatedly operated as many times as the set value of the repeat count.

The set value of dwell time does not apply to repeated index operation.

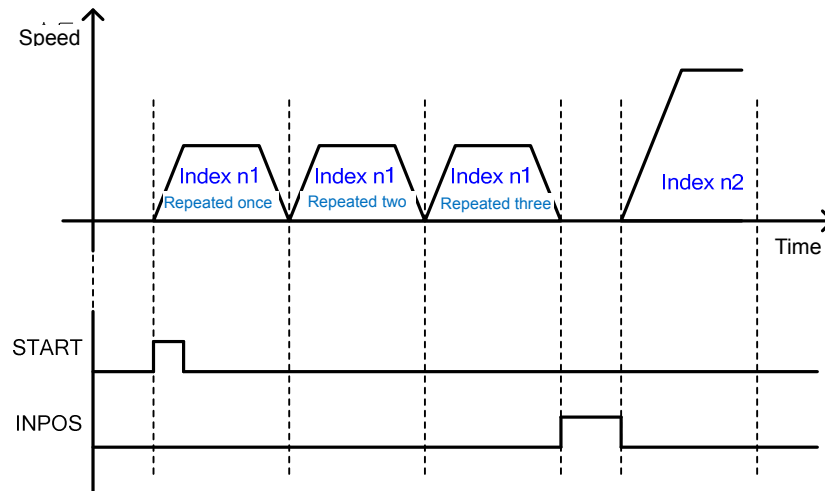

■ Dwell Time

It sets the dwell time for index operation (Unit: ms).

The set dwell time value is applied after the operation pattern of the index is generated.

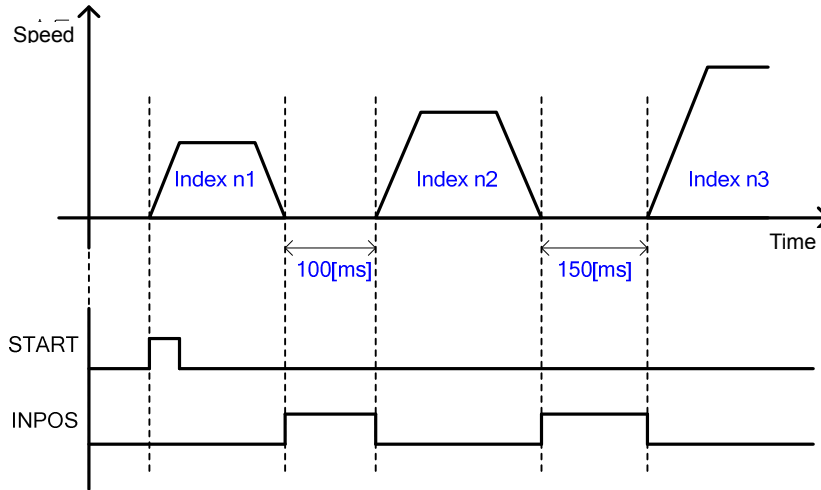

■ Next Index

It sets the number of the next index to automatically perform after the existing index is complete, If the action of the existing index is set to Next Index(set value 2).

Please see the explanation of 'Next Index' for further details.

■ Action

Under the Indexing Position mode, one of the three methods can be used depending on the action of the index.

- Stop

If the action of the index is set to Stop (set value 0), the overall sequence is completed after the relevant index is complete.

When the start signal is input from outside, the indexing position operation begins from the index (0~63) set as the start index (0x3008).

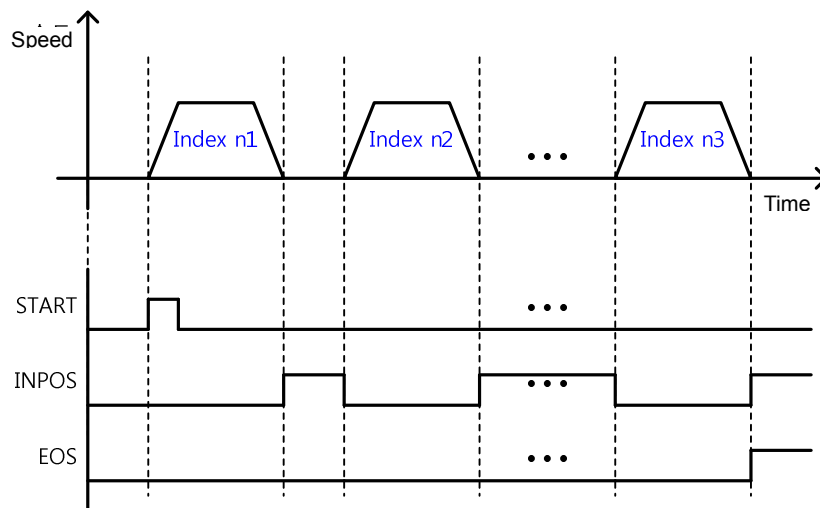

- Wait for Start

When the action of the index is set to Wait for Start (set value 1), the next index is performed by input of the Start signal after the relevant index is complete.

The index performed upon input of the start signal is determined by the ISEL0 ~ 5 (Index Select) signal. This is regardless of the value set for the next index.

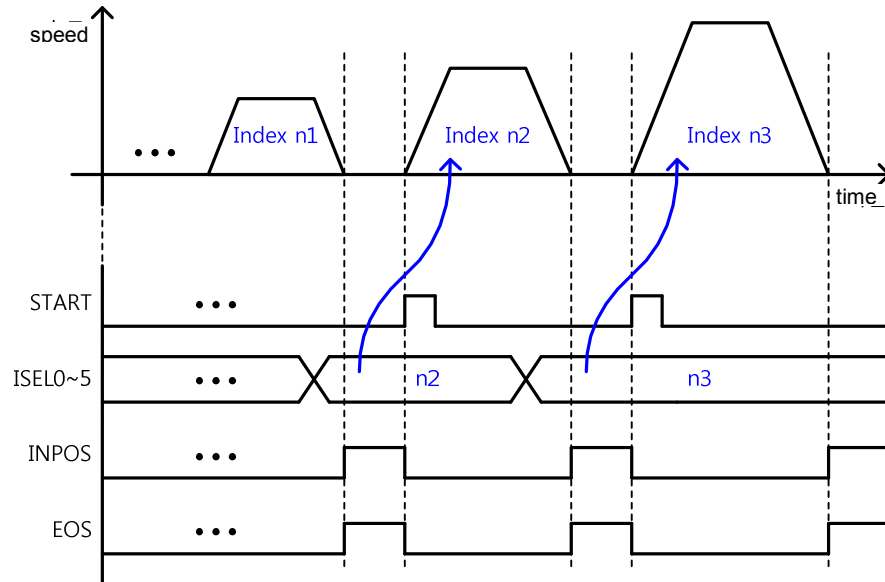

- Next Index

If the action of the index is set to Next Index(set value 2), the index set as the next index automatically begins after the end of the relevant index.

The preset index automatically begins without input of the digital input signal (START, ISEL0 ~ 5).

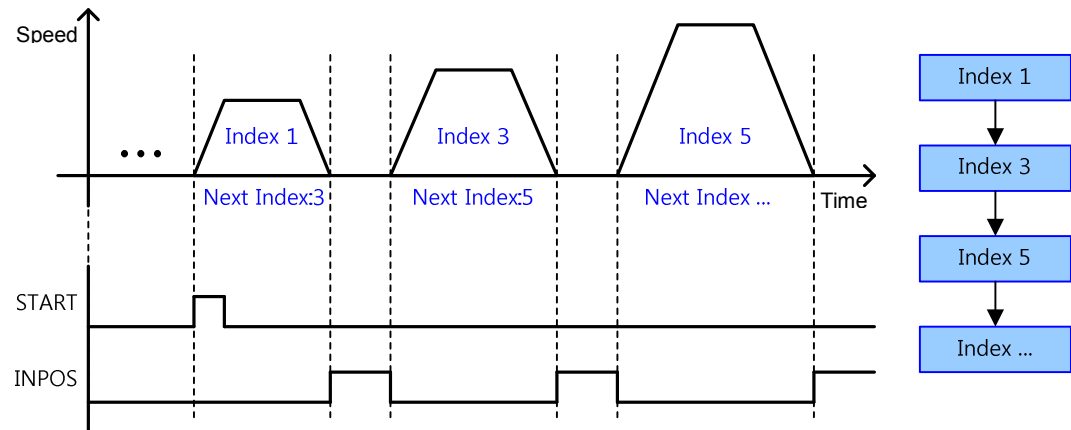

- Example of Action Setting

By combining the Wait for Start signal and the Next Index signal, a bifurcation structure shown in the figure below can be constructed.

To do this, the action of the index 3 should be set to Wait for Start.

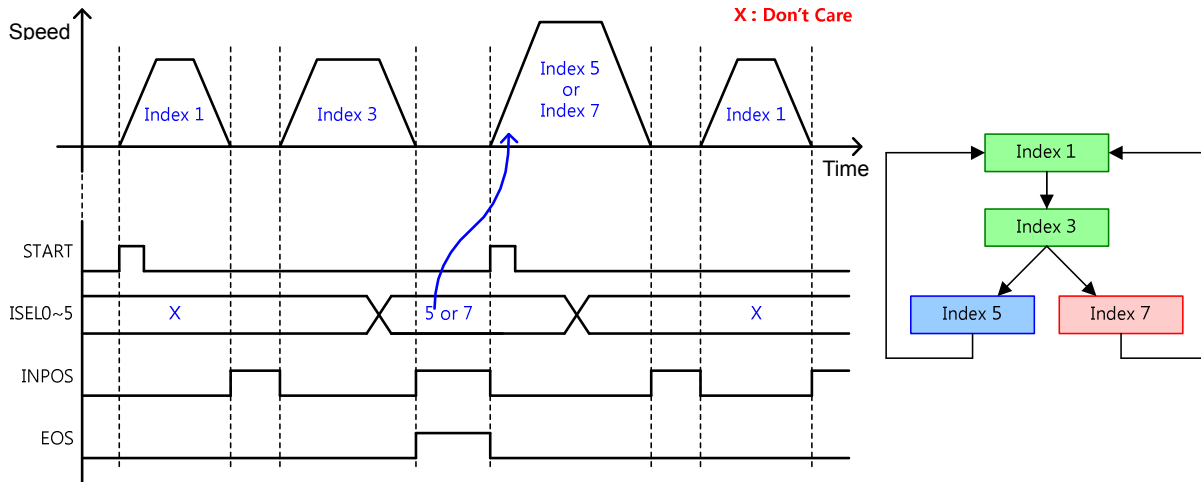

4.2 Index Type

L7P drive supports the 11 index types below for the Indexing Position mode.

4.2.1 Absolute / Relative Move

This is the most basic Point-to-Point (PTP) operation method where the motor rotates to the absolute or relative position based on the set speed and acceleration.

■ Absolute Move

The final distance is the difference between the distance and the current position.

Example) Absolute move when current position = 500 and Distance = 1000

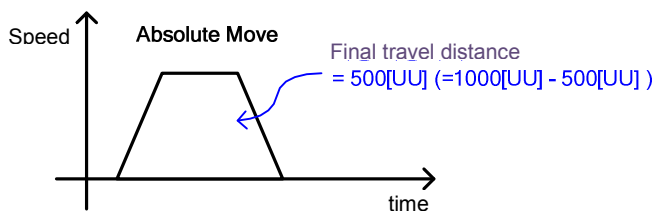

■ Relative Move

The final distance is the input value of the distance.

Example) Relative move when current position = 500 and Distance = 1000

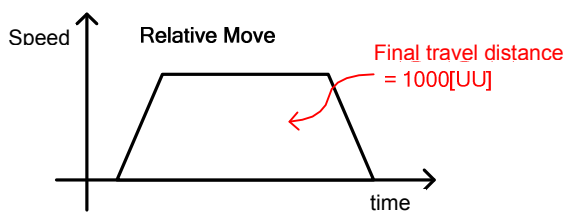

4.2.2 Registration Absolute / Relative Move

The operation speed and distance can be changed by REGT signal input from outside.

This function is similar to the motion pattern generation function of the VP-3, our previous model.

■ Registration Absolute Move

Performs absolute move to the set value of the. The motor is rotated to the set registration position at the set registration speed. The distance after REGT signal input is the set registration distance.

■ Registration Relative Move

Performs relative move to the set value of the. The motor is rotated to the set registration position at the set registration speed. The distance after REGT signal input is the set registration distance

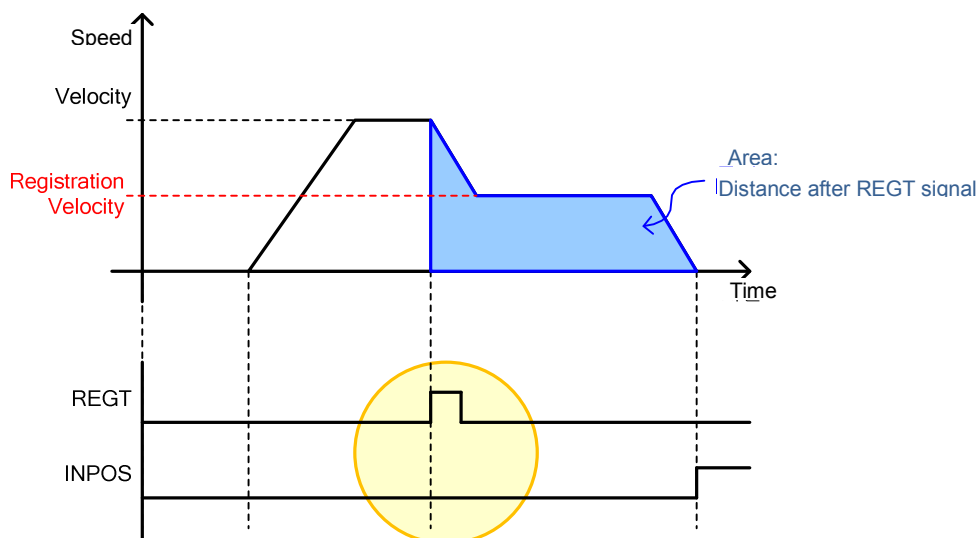

4.2.3 Blending Absolute / Relative Move

Performs a single operation pattern by combining consecutive indexes

After end of each index, moves on to the next index without stopping at 0 speed

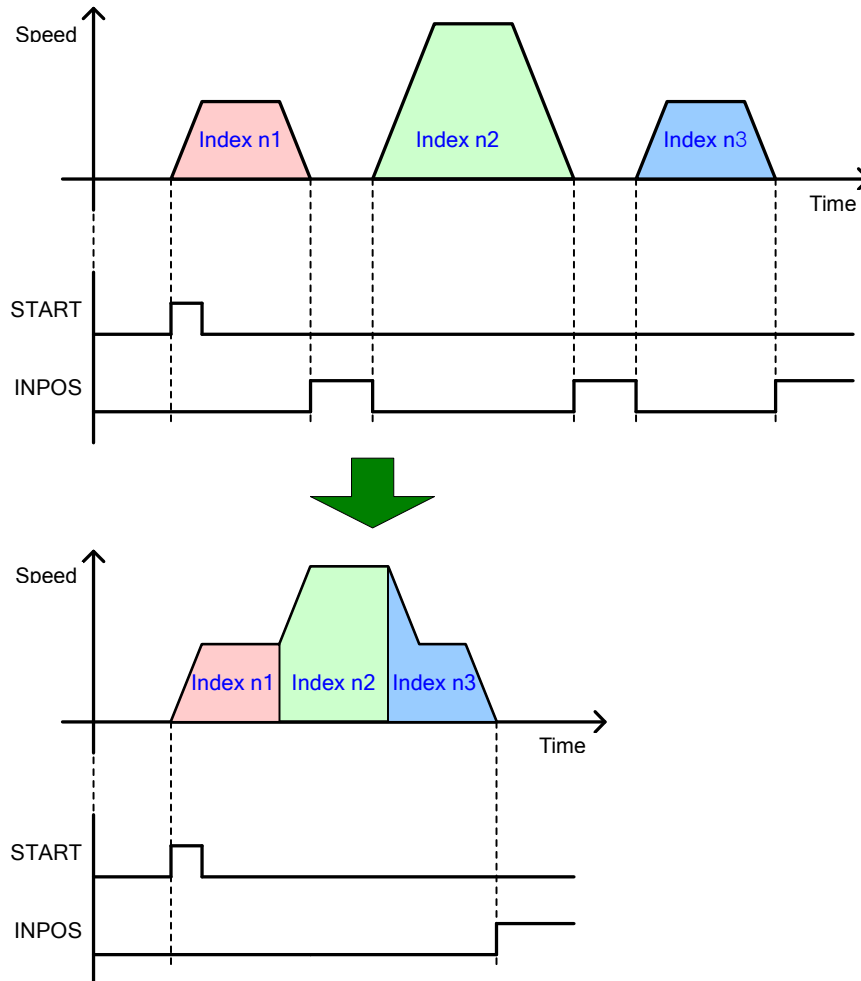

4.2.4 Rotary Absolute / Relative Move

■ Rotary Absolute Move

This mode can be used only when the coordinate is set to rotary coordinate.

The direction of rotation is determined based on the relationship between the start position and the command position. If the start position is less than the command position, the motor rotates forward. In the opposite case, the motor rotates counter-clock wise. The direction is not necessarily determined based on shorter movement.

Distance may be set to above one cycle (the value set for Modulo Factor: 0x240C), and negative values can be input (if Modulo Factor is 360°, -90° is the same as 270°). In this case, the final position is determined considering the Modulo Factor. Inputting a negative value is a useful way to make the motor rotate reverse past the 0 position.

Depending on the command value, the motor may rotate more than 1 cycle.

The figure below shows forward rotation from 30° to 240° and reverse rotation from 300° to 240°.

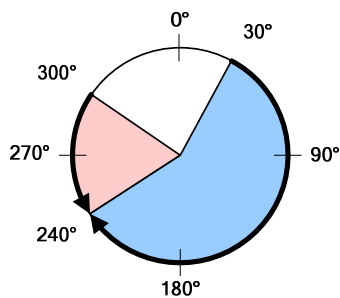

■ Rotary Relative Move

This mode can be used only when the coordinate is set to rotary coordinate.

If the distance has a positive value, the motor rotates in the positive direction, and if the distance has a negative value, the motor rotates in the negative direction. Distance may be set to above one cycle (the value set for Modulo Factor: 0x240C), and depending on the command value, the motor may rotate more than 1 cycle.

The figure below shows rotating +180° from 30° to 210° and rotating -120° from 30° to -90°.

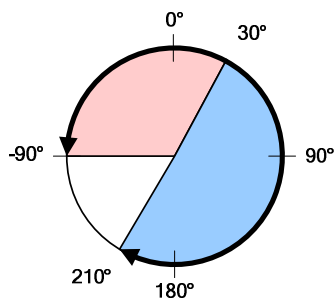

4.2.5 Rotary Shortest Move

This mode can be used only when the coordinate is set to rotary coordinate.

The direction is determined based on the shorter distance from the current position.

The motor rotates within one cycle (value set for Modulo Factor: 0x240C). The set distance value is processed as absolute value.

The figure below shows reverse rotation (the direction with the shorter distance) from 30° to 310°, and forward rotation from 30° to 180°.

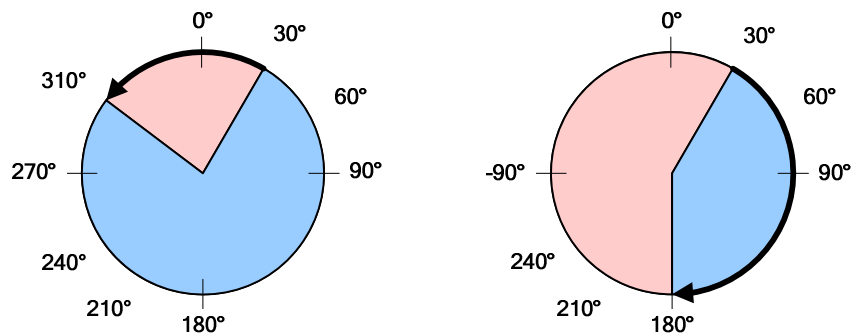

4.2.6 Rotary Positive / Negative Move

■ Rotary Positive Move

This mode can be used only when the coordinate is set to rotary coordinate.

The motor rotates always forward regardless of the start position and the command position (Distance).

The motor rotates within one cycle (value set for Modulo Factor: 0x240C). The set distance value is processed as absolute value.

The figure below shows forward rotation from 300° to 30° and from 30° to 180°.

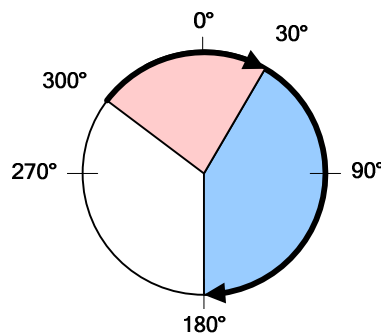

■ Rotary Negative Move

This mode can be used only when the coordinate is set to rotary coordinate.

The motor rotates always reverse regardless of the start position and the command position (Distance).

The motor rotates within one cycle (value set for Modulo Factor: 0x240C). The set distance value is processed as absolute value.

The figure below shows reverse rotation from 60° to 340° and from 340° to 180°.

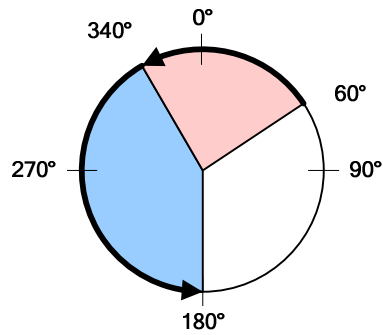

4.3 Functions of the Index Input Signals

■ Pause

When the pause signal (rising edge) is input during index operation, the current index is paused.

The remaining distance is rotated when the pause signal (rising edge) is input again

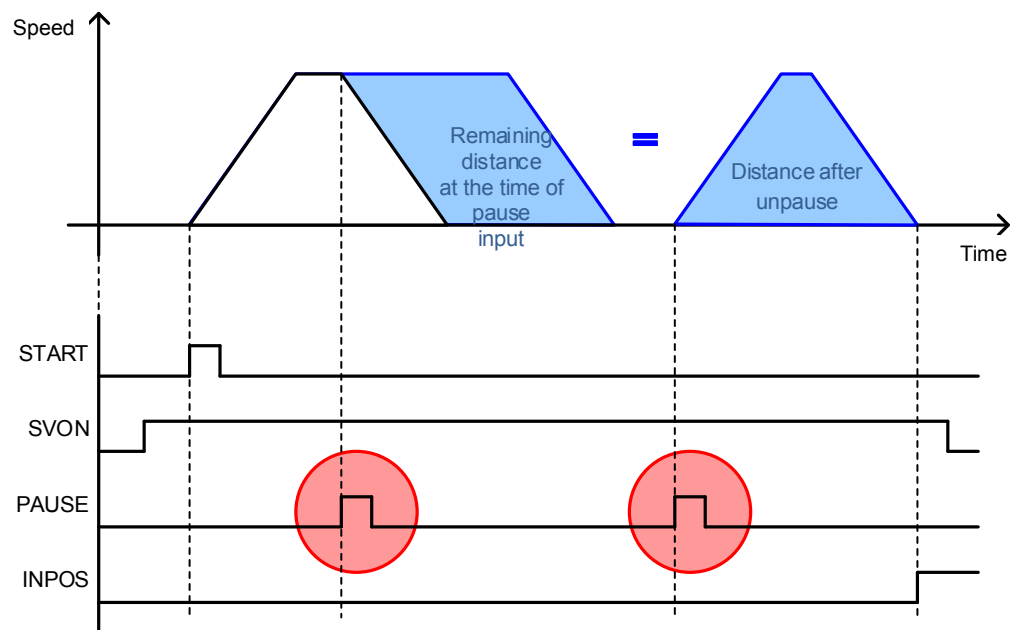

■ STOP

When the stop signal (Rising Edge) is input, the motor stops at the set deceleration (0x6085), ending the index operation sequence.

When the start signal is input again, the operation resumes from the index set as the start index (0x3008).

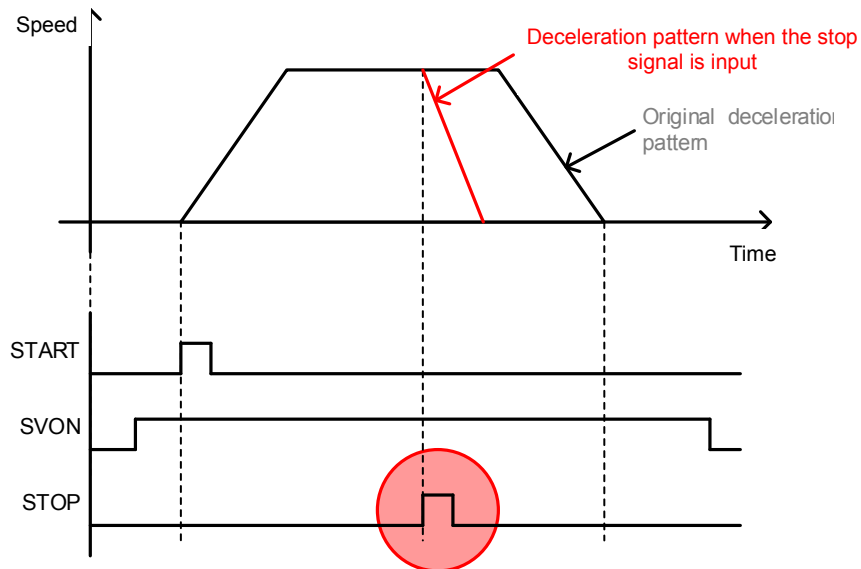

■ HSTART, ORG

When the HSTART signal (Rising Edge) is input, the motor returns to the original position. Hstart signal input during the return is disregarded.

After returning to the original position, the ORG (origin) signal is displayed. At the start of the return to the origin, the ORG signal is rest to 0.

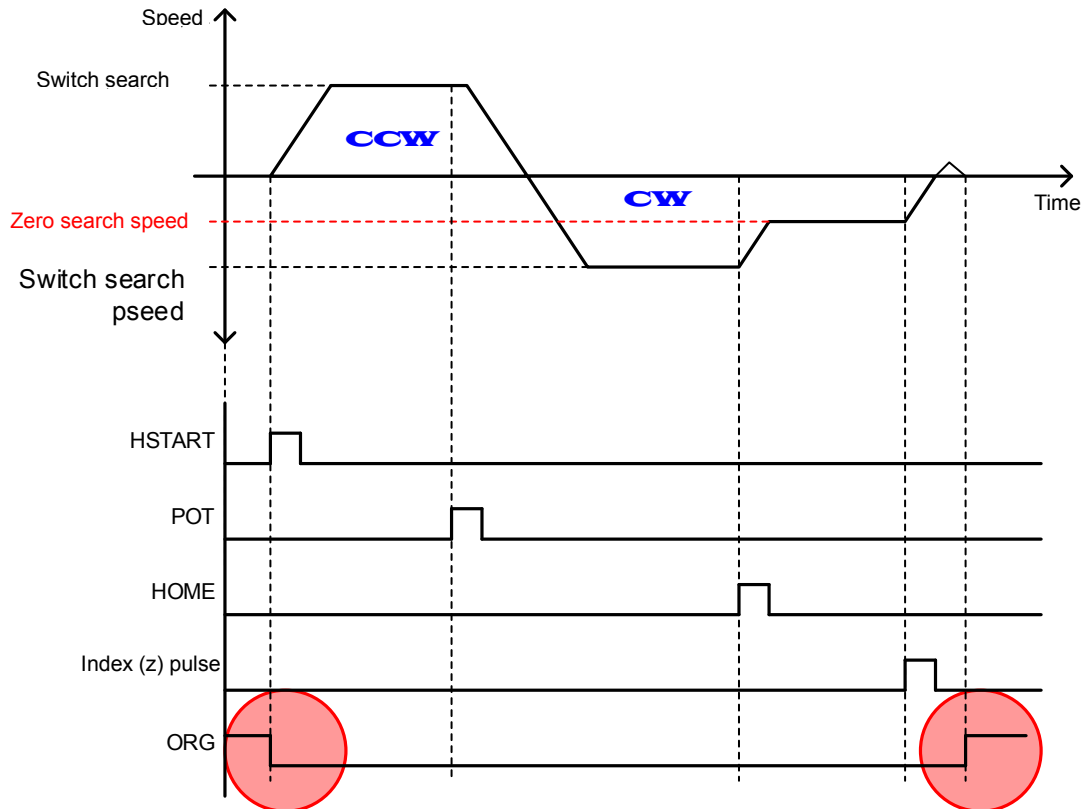

■ JSTART / JDIR

For tuning the machine or setting the original position, the motor can be roated to any position by JOG operation. The JSTART signal input from outside enables or suspends JOG operation, and the JDIR signal input from outside changes the rotation direction of the servo motor. JOG operation is performed using the speed control mode.

Related Objects	Description
JOG operation speed (0x2300)	See 10.4Speed Control-related Setting.
Speed command acceleration time (0x2301)	
Speed command deceleration time(0x2302)	
Speed command S-curve time (0x2303)	

- Servomotor rotation direction.

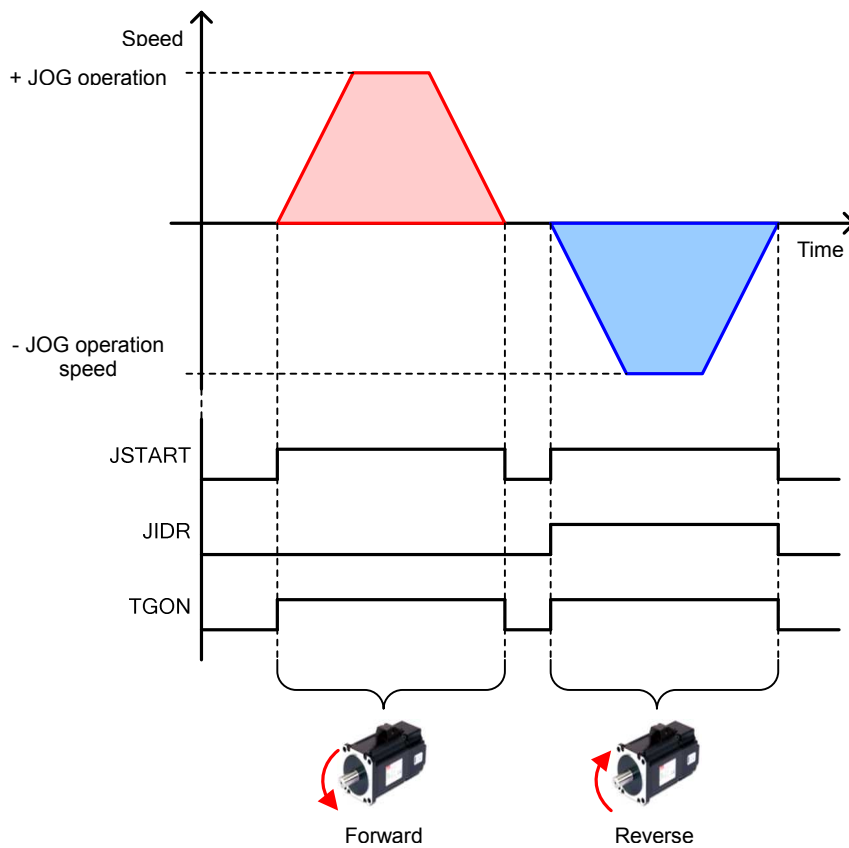

4.4 Functions of the Index Output Signal

■ EOS(End of Index Sequence)

When the indexation is Stop or Wait for Start, the EOS(End of Sequence) signal is displayed.

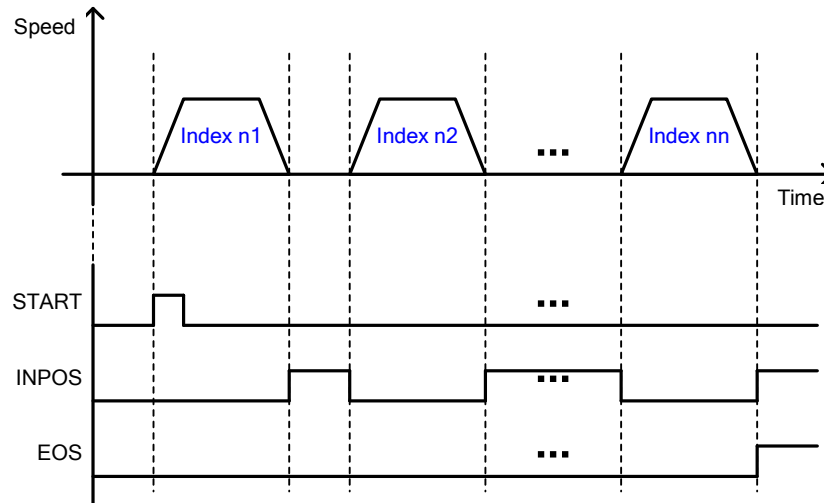

■ IOUT0~5(IndexOutput 0~5)

The number of index currently performed is displayed (IOUT0~5)

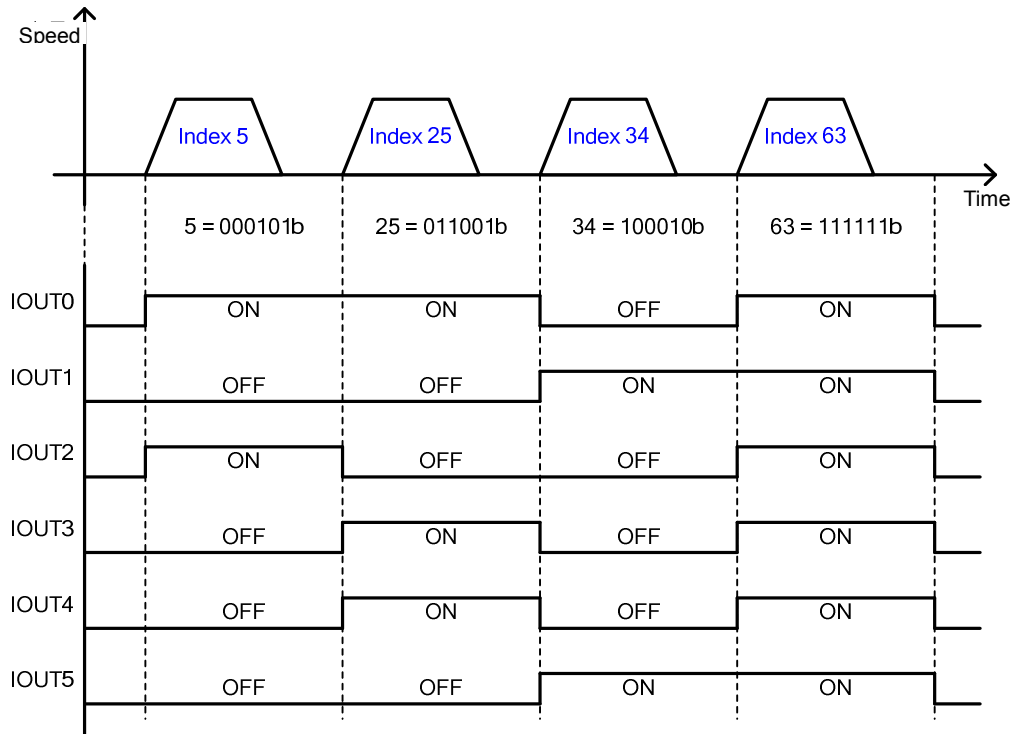

As for Index output, the output signals of the current position is initialized when control mode is changed or SVON is OFF. As Intialized output state is the same state as the operation output state of Index0, Please use as much as possible from index1

4.5 Analog Speed Override

As shown in the figure below, you can override the index speed depending on the analog input when operating index position. This function applies when the analog speed override mode (0x221E) is set to 'Use'. By setting the analog speed override offset(0x221F), you can adjust the offset of the input voltage. The unit is [mV].

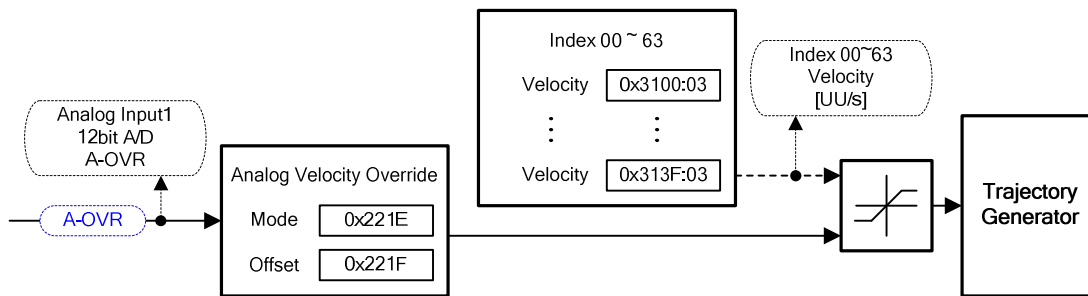

■ A-OVR(analogspeedoverride)

The relationship between analogspeedoverrideand input voltage is as shown below. When the input voltage is -10[V], 0[V] and 10[V] , the applied speed override is 0[%],100[%], and 200[%], respectively.

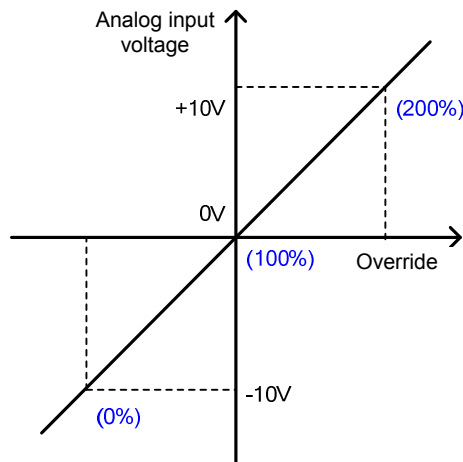

■ Related Objects

Index	Sub Index	Name	Variable Format	Access	PDO Allotcation	Unit
0x221E	-	analogspeedoverridemode (Analog Speed Override Mode)	UINT	RW	Yes	-
0x221F	-	analogspeedoverrideoffset (Analog Speed Override Offset)	INT	RW	Yes	mV

5. Pulse Input Position Operation

You can operate pulse input-type position control using a host controller with position determination function.

To do this, the contro lmode [0x3000] should be set to 1.

The figure below shows the internal block diagram of pulse input-type position control mode.

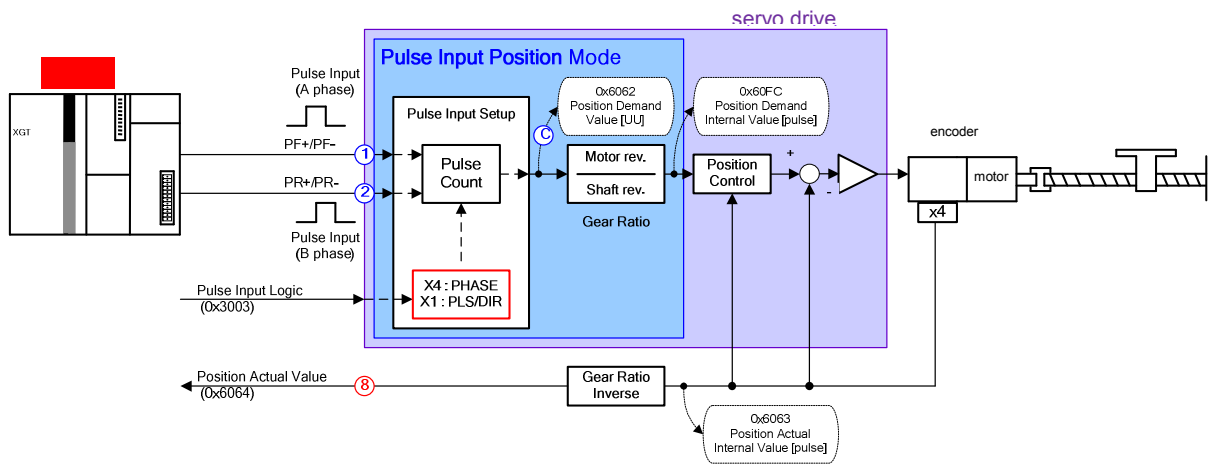

5.1 Function Setting of Pulse Input Logic

You can set the logic of the pulse strings from the host controller. The shapes of the input pulses and the direction of rotation for each logic are as follows.

Set Values	Details
0	PHASE A+PHASE B,Positive Logic
1	CW+CCW,Positive Logic
2	Pulse+sign,Positive Logic
3	PHASE A+PHASE B,Negative Logic
4	CW+CCW,Negative Logic
5	Pulse+Sign,Negative Logic

PF + PR		Forward rotation	Reverse rotation
Phase A +Phase B positive logic	0	PULS (I/O-31) SIGN (I/O-33)	PULS (I/O-31) SIGN (I/O-33)
CW +CCW positive logic	1	PULS (I/O-31) SIGN (I/O-33)	PULS (I/O-31) SIGN (I/O-33)
Pulse+ direction positive logic	2	PULS (I/O-31) SIGN (I/O-33)	PULS (I/O-31) SIGN (I/O-33)

PF + PR		Forward rotation	Reverse rotation
Phase A +Phase B negative logic	3	PULS (I/O-31) SIGN (I/O-33)	PULS (I/O-31) SIGN (I/O-33)
CW +CCW negative logic	4	PULS (I/O-31) SIGN (I/O-33)	PULS (I/O-31) SIGN (I/O-33)
Pulse+ direction negative logic	5	PULS (I/O-31) SIGN (I/O-33)	PULS (I/O-31) SIGN (I/O-33)

■ Related Objects

Index	Sub Index	Name	Variable Format	Accessibility	PDO Allocation	Unit
0x3003	-	Pulse Input Logic Select	UINT	RW	No	-

5.2 Function Setting of Pulse Input Filter

You can set the bandwidth of the digital filter of the pulse input unit. This can be used for the purpose of reducing the wire noises.

The bandwidths were calculated based on the width of the input pulses, considering the characteristics of digital filters.

Set Value	Details
0	No Filter
1	500Khz (Min)
2	750Khz
3	1Mhz (Default)
4	1.25Mhz

■ Related Objects

Index	Sub Index	Name	Variable Format	Accessibility	PDO Allocation	Unit
0x3004	-	(Pulse Input Filter Select)	UINT	RW	No	-

5.3 Function Setting of PCLEAR

You can set the action mode for when the position pulse clear (PCLR) signal is input. When the PCLR signal is input, the position error within the drive becomes 0.

Set Value	Setting Details
0	Edge mode
1	Operates in Level mode (Torque: maintained)
2	Operates in Level mode (Torque: 0)

■ Related Objects

Index	Sub Index	Name	Variable Format	Accessibility	PDO Allocation	Unit
0x3005	-	PCLEAR Mode Select	UINT	RW	No	-

6. Velocity Control

6.1 Fuction Set of Velocity command swtich

Mode set of velocity command for Velocity control

Index	Sub Index	Name	Variable Format	Accessibility	PDO	Variable Format
0x231A	-	Velocity Command Switch Select	UINT	RW	No	-

Set Value	Setting Details
0	Use Analoge speed command
1	Use input contact SPD1, SPD2 and Analog command speed.
2	Use input contact SPD1, SPD2, SPD3 and Analog speed command
3	Use input contact SPD1, SPD2, SPD3 Speed

Analog speed command when the contact is on after setting the vlaule, 1 or 2.

Ex 1) Set value is 2 and, Inpt Analog command 10[V] in the state that SPD1 and SPD2 are on

Operating motor speed is 100[rpm] and not available analog input command speed

Operating speed is operated by multistep command speed in the set value of parameter

0x2315

Ex 2) Set value is 2 and, Inpt Analog command 10[V] in the state that SPD1, SPD2 and SPD3 are on

Operating motor speed is 1000[rpm] and not available digital input command speed

Operating speed is operated by analog speed command voltage in the set value of parameter

0x2229

6.2 Analog Velocity Command

When selected 0, 1, 2 in velocity command switch, possible to use velocity control by external analog voltage,

To input command, Input -10[V] ~ +10[V] to I/O connector no.9 and no.10

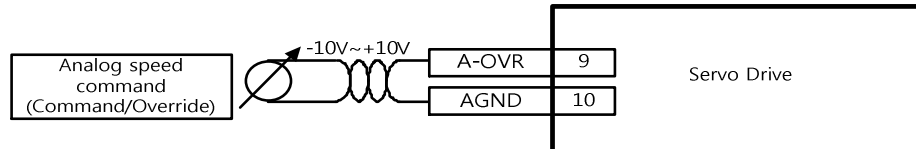

■ Related objects

Index	Sub Index	Name	Variable Format	Accessibility	PDO Allocation	Unit
0x2227	-	Analog Velocity Command Filter Time Constant	UINT	RW	No	-
0x2229	-	Analog Velocity Command Scale	INT	RW	No	-
0x222A	-	Analog Velocity Command Clamp Level	UINT	RW	No	-

■ Analog velocity command scale

1[rpm] unit set for analog velocity command per 1[V]

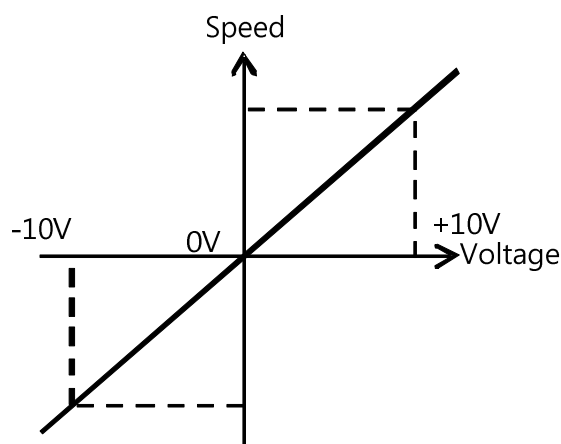

■ Analog velocity command clamp level

Even if speed command on analog signal contact circuit is 0, some voltage may remain. For that

case, possible to keep zero speed for the voltage command as much as setting speed

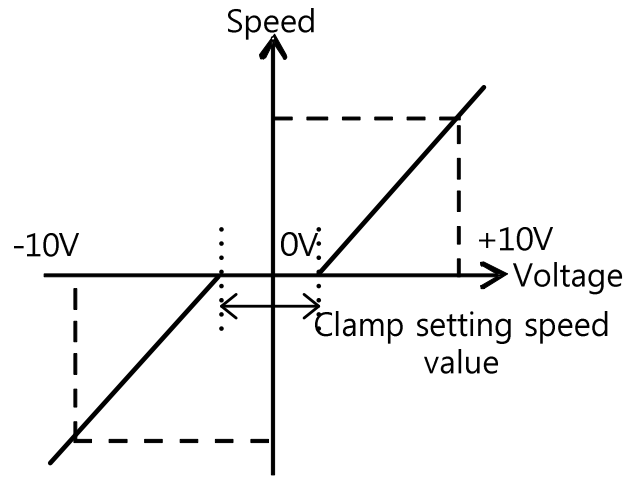

6.3 Digital Speed Command

When selected 1, 2, 3 in speed command switch, possible to use speed control by Servo Drive digital speed command

To use digital speed command, allocate digital input signal SPD1, SPD2, SPD3 in I/O connector or control digital input signal SPD1, SPD2, SPD3 by communication.

■ Speed setting by Digital input signal

Input Device			Speed
SPD1	SPD2	SPD3	
X	X	X	Speed command 1 (Parameter 0x2312)
O	X	X	Speed command 2 (Parameter 0x2313)
X	O	X	Speed command 3 (Parameter 0x2314)
O	O	X	Speed command 4 (Parameter 0x2315)
X	X	O	Speed command 5 (Parameter 0x2316)
O	X	O	Speed command 6 (Parameter 0x2317)
X	O	O	Speed command 7 (Parameter 0x2318)
O	O	O	Speed command 8 (Parameter 0x2319)

7. Torque Control

7.1 Analog Torque Command Scale

[%] unit set for analog torque command per 1[V]

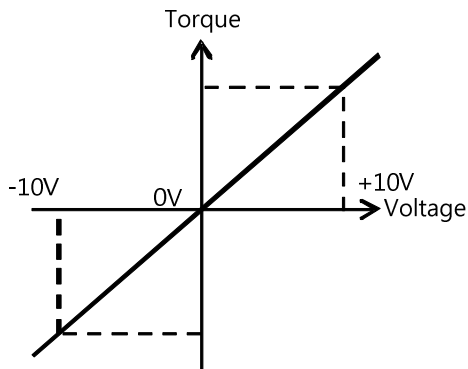

As related object is 0x221C analog torque input (Command/Limit) scale, this object has two functions.

0x221C		Analog Torque Input(command/limit) Scale					ALL
Index	Sub Index	Name	Variable Format	Accessability	PDO Allocation	Unit	Index
UINT	0 to 0xFFFF	100	0.1%/V	RW	No	Always	Yes

First, for not using torque control

When the set value of the torque limit function setting (0x2110) is 4(Analog torque limit), torque is limited by analog torque limit value.

Second, for using torque control

In the case of torque control, the parameter is used as analog torque command scale. Setting value, set on the percentage of the rated torque ratio by analog input voltage ratio

7.2 Speed Setting in Torque Control

In torque control, depending on the setting of 0x230D speed limit function, the motor speed is determined

Set Value	Setting Details
0	Limited by speed limit value(0x230E)
1	Limited by motor maximum speed

The default value of 230E is 1000[rpm]

Before operating, set operating speed value

■ Related objects

Index	Sub Index	Name	Variable Format	Accessibility	PDO Allocation	Unit
0x221C	-	Analog Torque Input(command/limit) Scale	UINT	RW	No	-
0x221D	-	Analog Torque Input(command/limit) Offset	INT	RW	No	-
0x2228	-	Analog Torque Command Filter Time Constant	UINT	RW	No	-
0x230D	-	Speed Limit Function Select	UINT	RW	No	-
0x230E	-	Speed Limit Value at Torque Control Mode	UINT	RW	No	-

8. The conversion of control mode

L7P Drive supports the conversion of operation mode depending on the setting value of control mode (0x3000) and digital input mode signals.

■ Control mode (0x3000) setting value

Set Value	Setting Details
0	Indexing Position Mode
1	Pulse Input Position Mode
2	Velocity Mode
3	Torque Mode
4	Pulse input position mode or Indexing position mode
5	Pulse input position mode or Velocity mode
6	Pulse input position mode or Torque mode
7	Velocity mode or Torque mode
8	Indexing position mode or Velocity mode
9	Indexing position mode or Torque mode

■ Control mode setting value : 4

Pulse input position mode is basic operation in this mode and, when Digital input MODE signal is on, converted into indexing position mode

■ Control mode setting value : 5

Pulse input position mode is basic operation in this mode and, when Digital input MODE signal is on, converted into Velocity mode

■ Control mode setting value : 6

Pulse input position mode is basic operation in this mode and, when Digital input MODE signal is on, converted into Torque mode

■ Control mode setting value : 7

Velocity mode is basic operation in this mode and, when Digital input MODE signal is on, converted into Torque mode

■ Control mode setting value : 8

Indexing position mode is basic operation in this mode and, when Digital input MODE signal is on, converted into Velocity mode

■ Control mode setting value : 9

Indexing position mode is basic operation in this mode and, when Digital input MODE signal is on, converted into Torque mode

9. Homing

This drive provides built-in homing function (return to origin). The figure below shows the relationship of input/out parameters to the homing mode. You can select speed, acceleration, offset and homing methods..

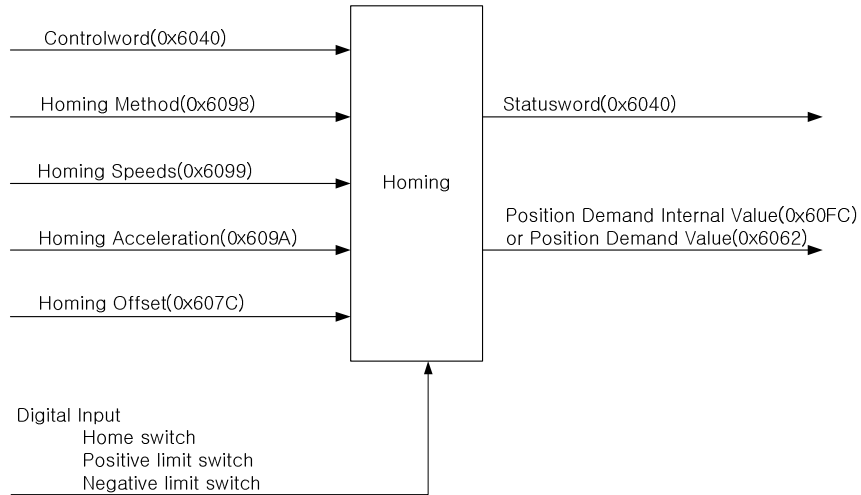

Using Home Offset, you can set the offset between the home position and the zero position of the machine, where 'zero position' means the position where the Position Actual Value (0x6064) is 0.

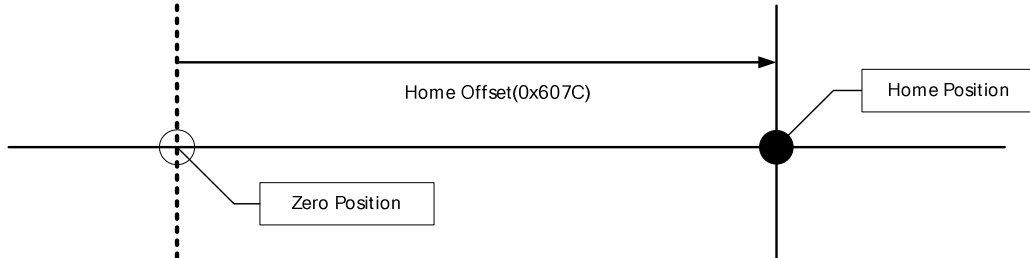

9.1 Homing Methods

This drive supports the following homing methods (0x6098).

Homing Methods (0x6098)	Description
1	During reverse operation, the motor is returned to origin by negative limit switch (NOT) and index (Z) pulse.
2	During forward operation, the motor is returned to origin by positive limit switch (POT) and index (Z) pulse.
7,8,9,10	During forward operation, the motor is returned to origin by homing switch (POT) and index (Z) pulse. While returning to origin, when positive limit switch (POT) is input, the direction changes.
11,12,13,14	During reverse operation, the motor is returned to origin by homing switch (POT) and index (Z) pulse. While returning to origin, when negative limit switch (NOT) is input, the direction changes.
24	During forward operation, the motor is returned to origin by homing switch (POT). While returning to origin, when positive limit switch (POT) is input, the direction changes.
28	During reverse operation, the motor is returned to origin by homing switch (POT). While returning to origin, when negative limit switch (NOT) is input, the direction changes.
33	During reverse operation, the motor is returned to origin by index (Z) pulse.
34	During forward operation, the motor is returned to origin by index (Z) pulse.
35	The current position is set as origin.
-1	During reverse operation, the motor is returned to the origin by reverse stopper and index (Z) pulse.
-2	During forward operation, the motor is returned to the origin by forward stopper and index (Z) pulse.
-3	During reverse operation, the motor is returned to the origin by reverse stopper
-4	During forward operation, the motor is returned to origin by forward stopper

■ Related Objects

Index	Sub Index	Name	Variable Format	Accessibility	PDO Allocation	Unit
0x6040	-	Controlword	UINT	RW	Yes	-
0x6041	-	Statusword	UINT	RO	Yes	-
0x607C	-	Home Offset	DINT	RW	No	UU
0x6098	-	Homing Method	SINT	RW	Yes	-
0x6099	-	Homing speed	-	-	-	-
	0	Number of entries	USINT	RO	No	-
	1	Speed during search for switch	UDINT	RW	Yes	UU/s
	2	Speed during search for zero	UDINT	RW	Yes	UU/s
0x609A	-	Homing Acceleration	UDINT	RW	Yes	UU/s ²

■ Homing Methods 1, 2

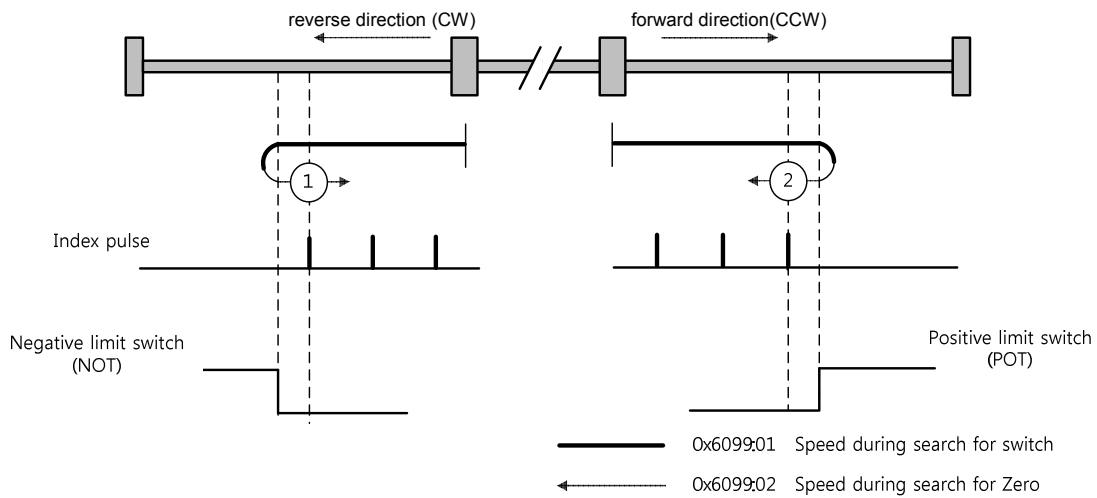

The speed profile for each sequence in case of using Homing Method 1 is as shown below. Please see the explanations below for further details.

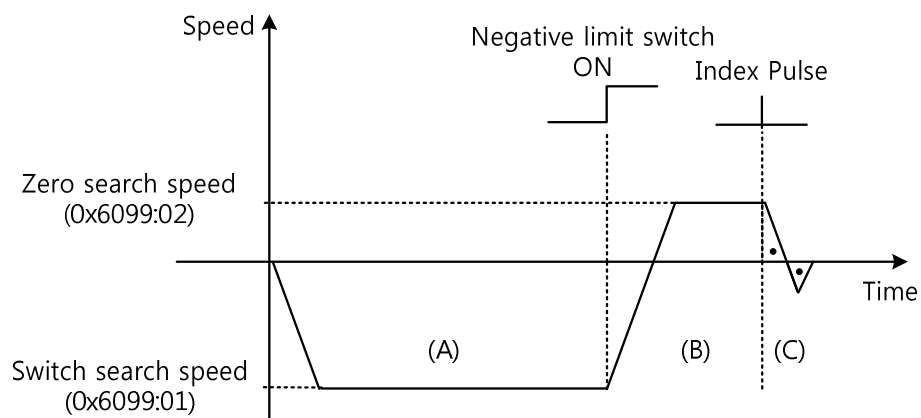
Homing Method ①

- (A) The initial direction is reverse (CW). The motor operates at the switch search speed.
- (B) When the negative limit switch (NOT) is on, the direction changes to forward (CCW). The motor decelerates to Zero search speed.
- (C) While operating at Zero search speed, the first index pulse is detected, and the motor rotates to the index position (Home).

■ **Methods 7, 8, 9, 10**

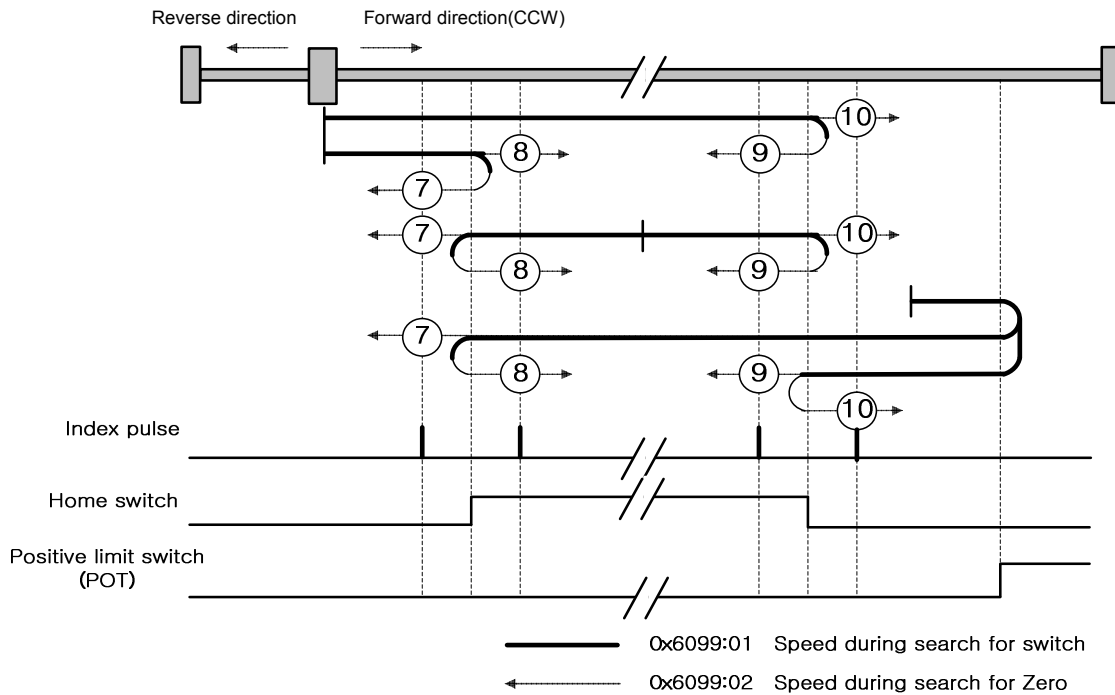

The speed profile for each sequence in case of using Homing Method 7 is as shown below. Please see the explanations below. The sequence varies in each of the three cases below, depending on the load position at the time of homing and the relationship of home switches. Please see the explanations below. Please see the explanations below for further details.

- (1) Cases where the home switch is off when homing begins, and the limit is not met in the process

Homing Method ⑦

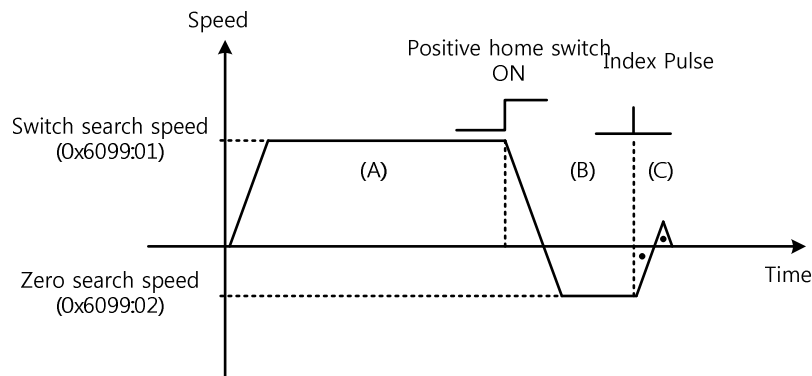

- (A) The initial direction is forward (CCW). The motor operates at the switch search speed.
- (B) When the positive limit switch (POT) is on, the motor decelerates to Zero search speed, and the direction changes to reverse (CW).
- (C) While operating at Zero search speed, the first index pulse is detected, and the motor rotates to the index position (Home).

(2) Cases where the home switch is on when homing begins

Homing Method ⑦

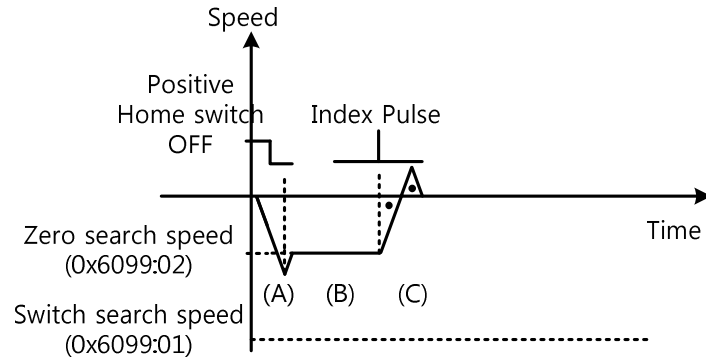

- (A) Since the home signal is on, the motor operates at the switch search speed in the positive home switch direction (CCW). Depending on the starting position, the switch search speed may not be reached.
- (B) When the Home Switch is off, the motor decelerates to Zero search speed.
- (C) While operating at Zero search speed, the first index pulse is detected, and the motor rotates to the index position (Home).

(3) Cases where the home switch is off when homing begins, and the limit is met in the process

Homing Method ⑦

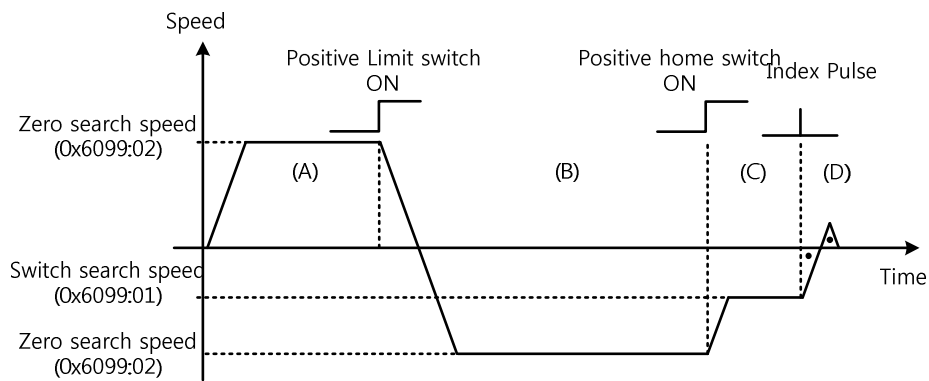

- (A) The initial direction is forward (CCW). The motor operates at the switch search speed.
- (B) When the positive limit switch (POT) is on, the motor decelerates and stops. Then, the motor operates reverse (CW) at the switch search speed.
- (C) When the Positive Home Switch is off, the motor decelerates to Zero search speed.
- (D) While operating at Zero search speed, the first index pulse is detected, and the motor rotates to the index position (Home).

The homing sequences of Methods 8, 9, 10 above are almost identical to those of Method 7 explained above, except for differences in initial direction and actions pertaining to Home switch positivity/negativity.

Positive Home Switch is determined based on the initial direction. The home switch first met while operating in the initial direction becomes the Positive Home Switch.

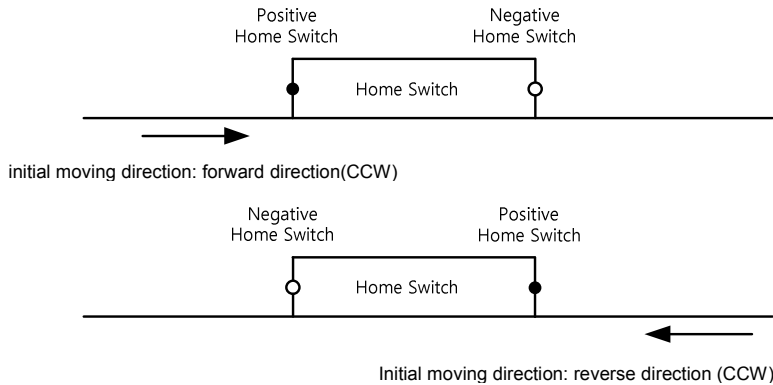

■ Methods 11, 12, 13, 14

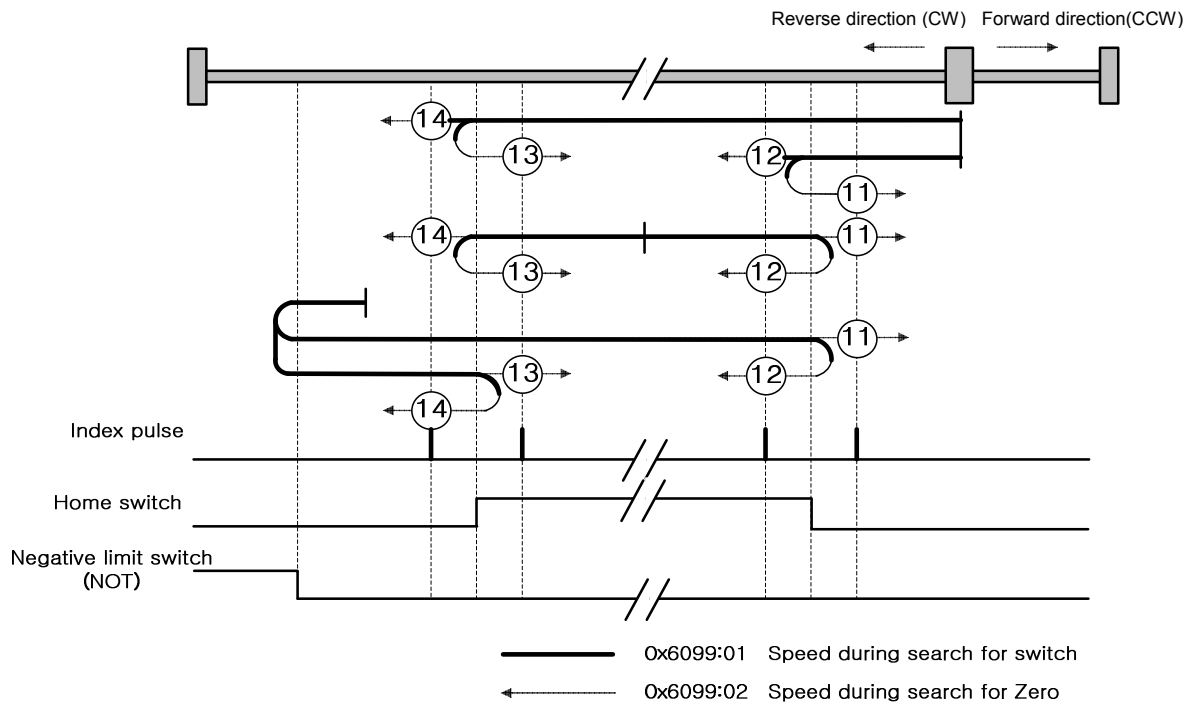

The speed profile for each sequence in case of using Homing Method 14 is as shown below. Please see the explanations below. The sequence varies in each of the three cases below, depending on the load position at the time of homing and the relationship of home switches. Please see the explanations below. Please see the explanations below for further details.Homing.

(1) Cases where the home witch is off when homing begins, and the limit is not met in the process

Homing Method ⑭

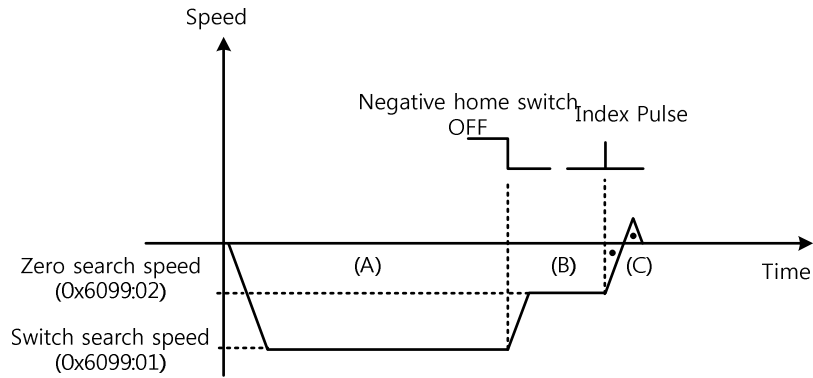

- (A) The initial direction is reverse (CW). The motor operates at the switch search speed.
- (B) When the negative limit switch (NOT) is off, the motor decelerates to Zero search speed, and the direction changes to reverse (CW).
- (C) While operating at Zero searchspeed, the first index pulse is detected, and the motor rotates to the index position (Home).

(2) Cases where the home switch is on when homing begins

Homing Method ⑭

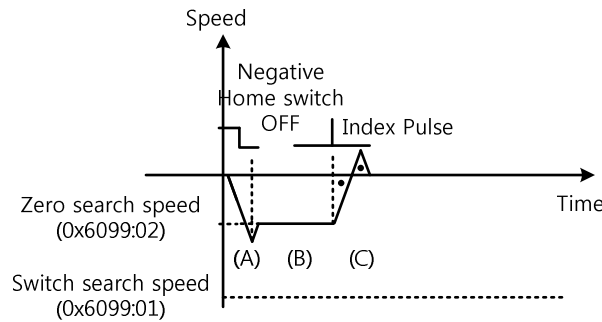

- (A) Since the home signal is on, the motor operates at the switch search speed in the negative home switch direction (CW). Depending on the starting position, the switch search speed may not be reached.
- (B) When the Home Switch is off, the motor decelerates to Zero search speed.
- (C) While operating at Zero searchspeed, the first index pulse is detected, and the motor rotates to the index position (Home).

(3) Cases where the home witch is off when homing begins, and the limit is met in the process

Homing Method 14

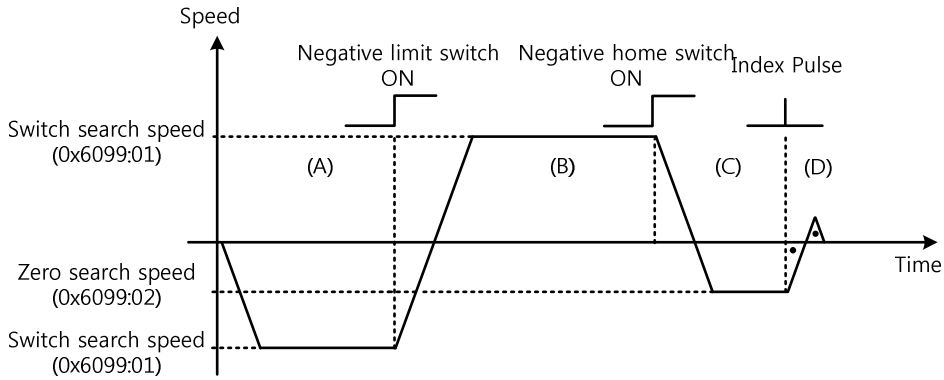

- (A) The initial direction is reverse (CW). The motor operates at the switch search speed.
- (B) When the negative limit switch (NOT) is on, the motor decelerates and stops. Then, the motor operates forward (CCW) at the switch search speed.
- (C) When the Negative Home Switch is on, the motor decelerates to Zero search speed. Then the direction changes to reverse (CW).
- (D) While operating at Zero search speed, the first index pulse is detected, and the motor rotates to the index position (Home).

The homing sequences of Methods 11, 12, 13 above are almost identical to those of Method 14 explained above, except for differences in initial direction and actions pertaining to Home switch positivity/negativity.

Method 24

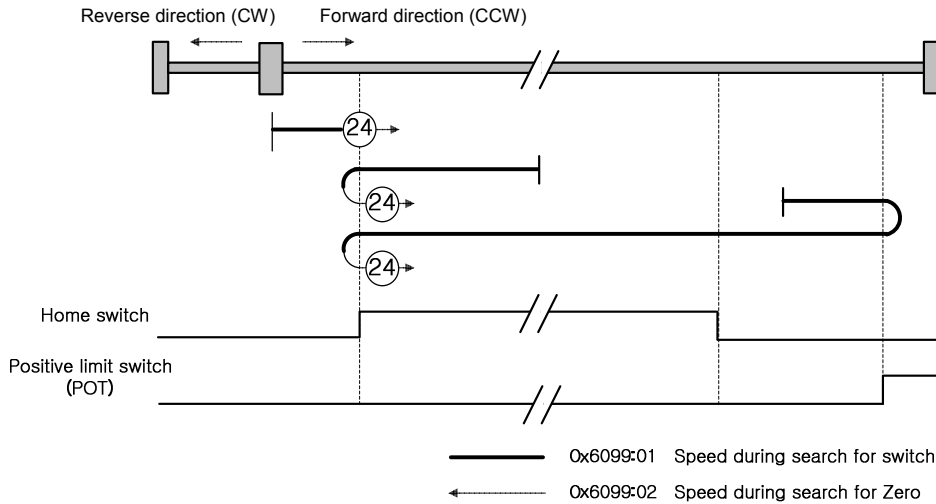

The initial direction is forward (CCW), and the position where the Positive Home Switch is on becomes the home position.

■ Method 28

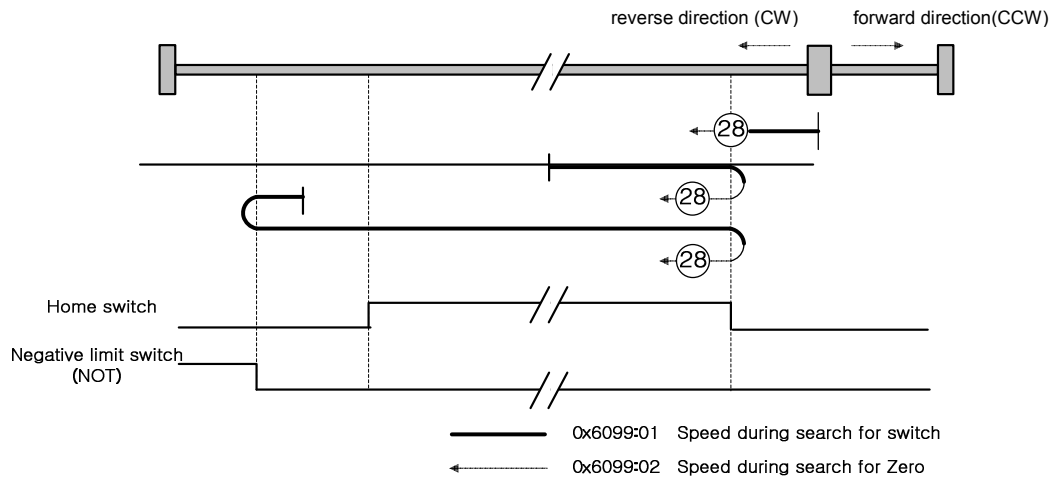

The initial direction is reverse (CW), and the position where the Positive Home Switch is on becomes the home position.

■ Methods 33, 34

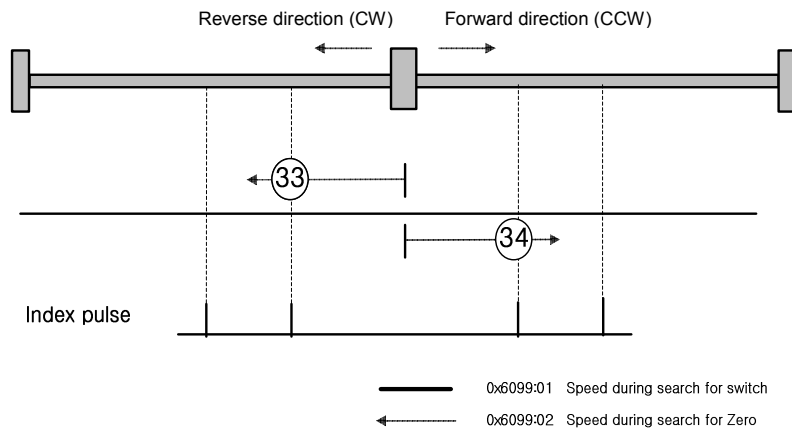

The initial position is reverse (CW) for Method 33 and forward (CCW) for Method 44. The index pulse is detected at Zero search speed.

■ **Method 35**

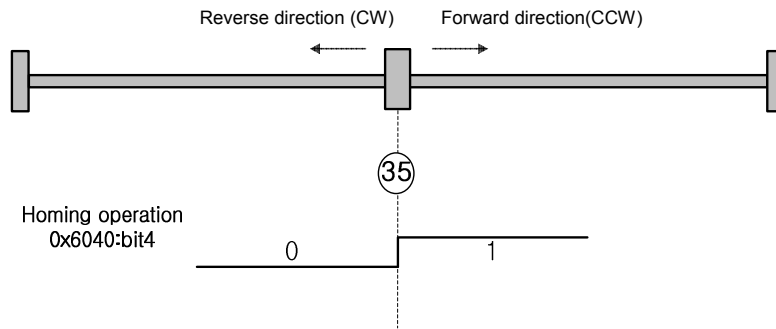

The current position when the homing begins becomes the home position. This method is used when changing the origin to the current position, as needed by the host controller.

Homing methods -1, -2, -3, -4 are homing methods supported by this drive other than the standard methods. You can use these methods when not using a separate home switch.

■ **Methods -1, -2**

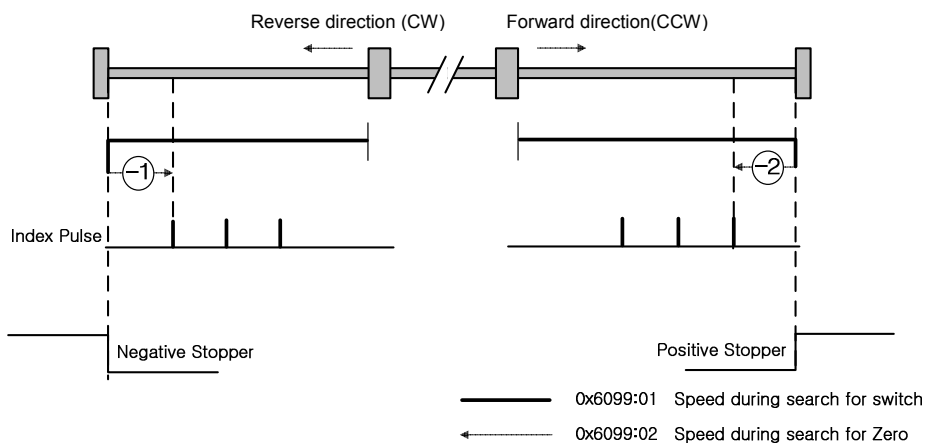

Homing Methods -1, -2 uses Stopper and Index(Z) pulse to return to origin. The speed profile of each sequence is as follows. Please see the explanations below for further details.

Homing Method ①

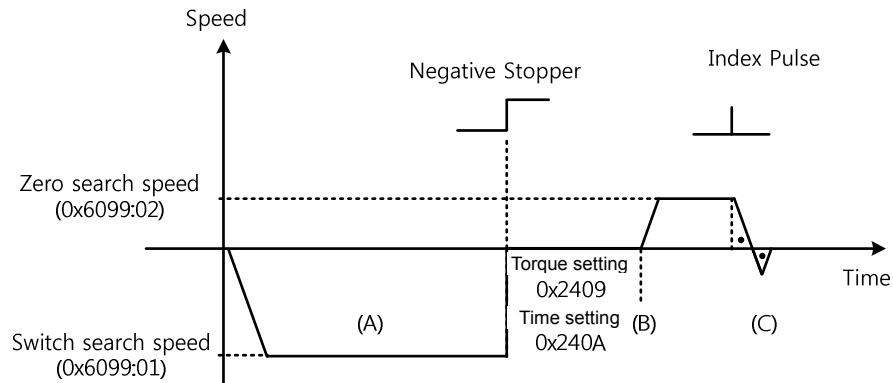

- (A) The initial direction is reverse (CW). The motor operates at the switch search speed.
- (B) When the motor hits the Negative Stopper, the motor stands by based on the torque limit for homing using stopper (0x2409) and set value of homing time (0x240A), and changes direction..
- (C) While operating at Zero search speed, the first index pulse is detected, and the motor rotates to the index position (Home).

Homing Method ②

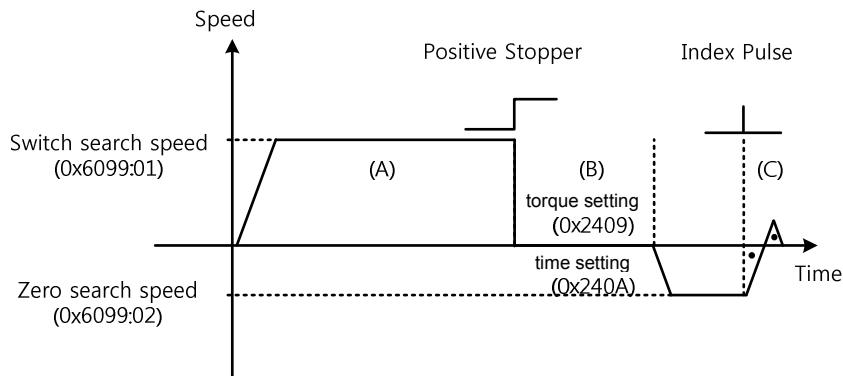

- (A) The initial direction is forward (CCW). The motor operates at the switch search speed.
- (B) When the motor hits the Positive Stopper, the motor stands by based on the torque limit for homing using stopper (0x2409) and set value of homing time (0x240A), and changes direction..
- (C) While operating at Zero search speed, the first index pulse is detected, and the motor rotates to the index position (Home).

■ Methods -3, -4

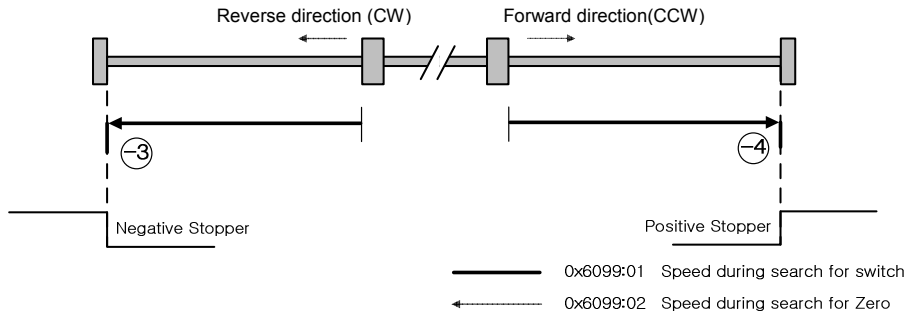

Homing Methods -1, -2 uses only Stopper to return to origin. The speed profile of each sequence is as follows. Please see the explanations below for further details.

Homing Method -3

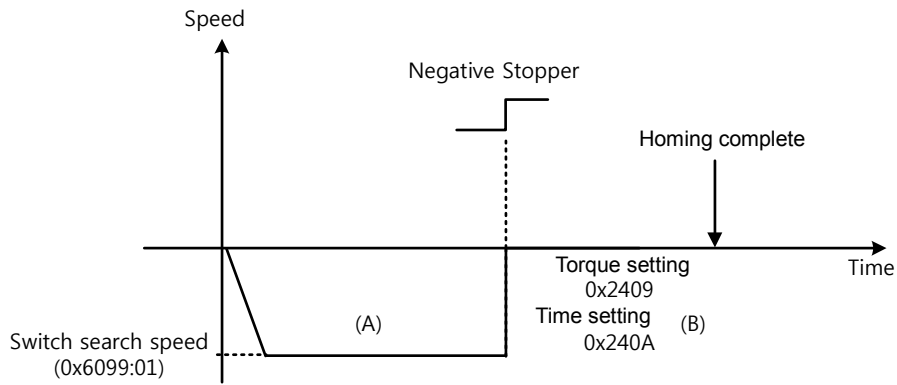

- (A) The initial direction is reverse (CW). The motor operates at the switch search speed.
- (B) When the motor hits the Negative Stopper, the motor stands by based on the torque limit for homing using stopper (0x2409) and set value of homing time (0x240A), and changes direction..

Homing Method ④

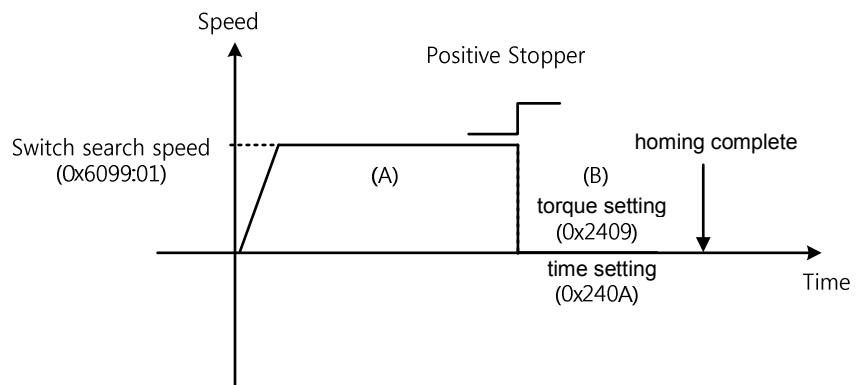

- (A) The initial direction is forward (CCW). The motor operates at the switch search speed.
- (B) When the motor hits the Positive Stopper, the motor stands by based on the torque limit for homing using stopper (0x2409) and set value of homing time (0x240A), and changes direction..

10. Application Functions

10.1 Drive Front Panel

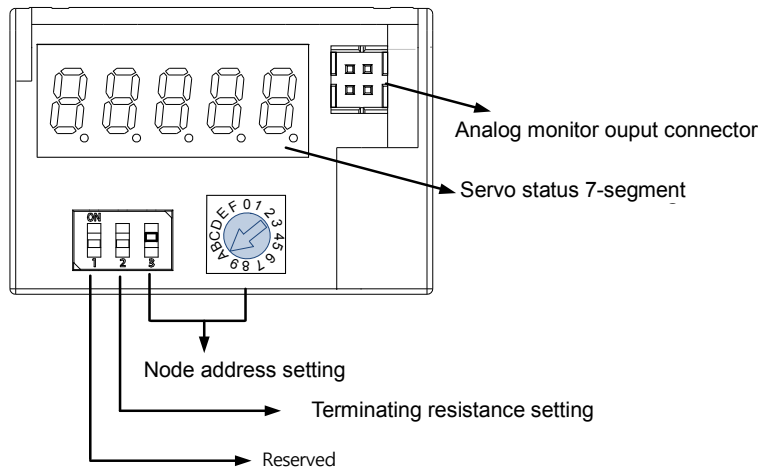

10.1.1 7-Segment for Servo Status Display

7-Segment for servo status display consist of the following 5 digits, from Digit 1 to Digit 5, starting from the right..

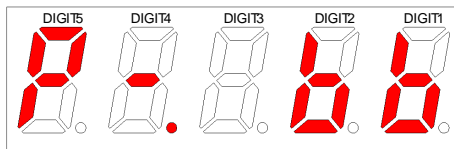

Digit 3~1 of 7 –Segment, unless the servo alarm is set off, displays the following drive statuses. Display of servo warning is given priority over other statuses.

Digit 3~Digit 1 Display	Status Description
<p>Servo off</p>	<p>Positive limit sensor input</p>
<p>Negative limit sensor input</p>	<p>Servo on</p>

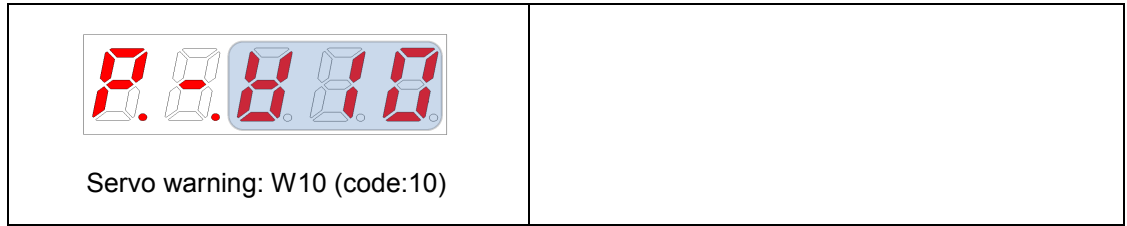

Digit4 displays the current operation status and the servo's READY status.

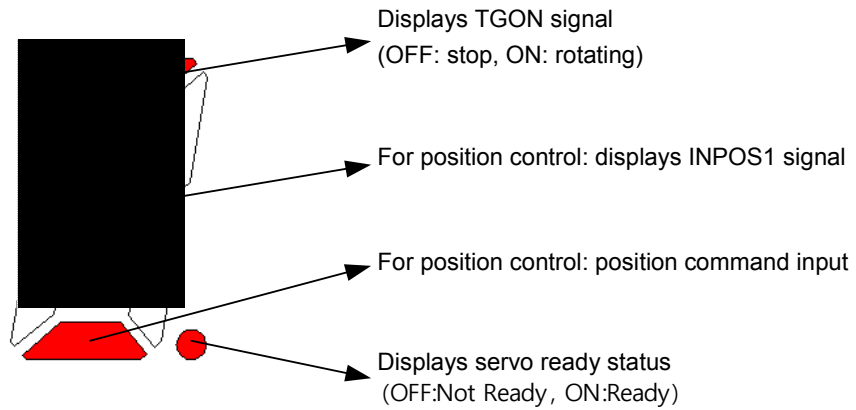

Digit5 displays the current control mode and the servo ON status.

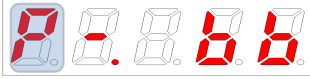
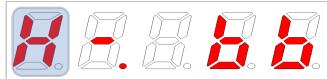
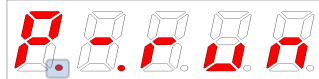
Displays operation mode and status		
 <p>Position control mode: Index, Pulse Input</p>	 <p>Homing mode</p>	 <p>(ON: Servo ON)</p>

In case of servo alarm, DIGIT 5~1 blinks and displays the following message, where DIGIT2 and 1 display the alarm code. Display of servo warning is given priority over other statuses

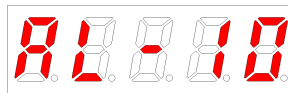

Example of alarm status display
AL-10 (IPM Fault)

Example 1) limit signal input	Example 2) servo warning
<p>Positive limit input</p> <p>INPOS1, servo READY</p> <p>Position control mode, servo READY</p>	<p>W01 (main power fail) + W40 (low-voltage warning) occurrence INSPD, speed command input, servo READY</p> <p>Speed control mode, servo ON</p>

10.1.2 Drove Node Address Setting

You can set the address of the drive's nodes. You can confirm the set addresses at node ID (0x2003). The value of the node switch is read only once when the power is turned on. The set value changed after that point applies when the power is turned on again next time.

The node switch of this drive consistof a rotary switch capable of setting values from 0 to 15 (F) and toggle switches that can be turned On or Off. In total, you can set node addresses from 0 to 31.

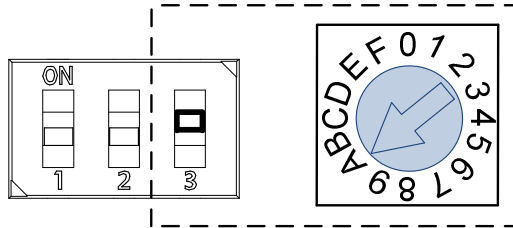

Rotary switch setting	0	1	2	3	4	5	6	7	8	9	A
Toggle switch setting	OFF	OFF	OFF	OFF	OFF	OFF	OFF	OFF	OFF	OFF	OFF
Node address	0	1	2	3	4	5	6	7	8	9	10

Rotary switch setting	B	C	D	E	F	0	1	2	3	4	5
Toggle switch setting	OFF	OFF	OFF	OFF	OFF	OFF	ON	ON	ON	ON	ON
Node address	11	12	13	14	15	16	17	18	19	20	21

Rotary switch setting	6	7	8	9	A	B	C	D	E	F	
Toggle switch setting	ON	ON	ON	ON	ON	ON	ON	ON	ON	ON	
Node address	22	23	24	25	26	27	28	29	30	31	

10.1.3 Terminating Resistance Setting

The terminating resistance used for RS-422 communication is configured within this drive.

The terminating resistance inside the drive is 120Ω. To use the terminating resistance, turn on the switch as shown in the figure below.

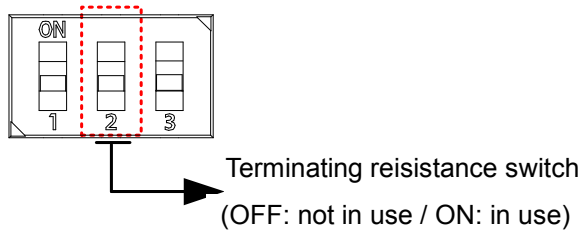

10.2 Input/Output Signal Setting

10.2.1 Allocating Digital Input Signals

You can set the functions of digital input signal of I/O connector and input signal level. Among the 28 input functions listed below, you can allocate the functions that you want to use to digital input signals 1 through 16 at your discretion.

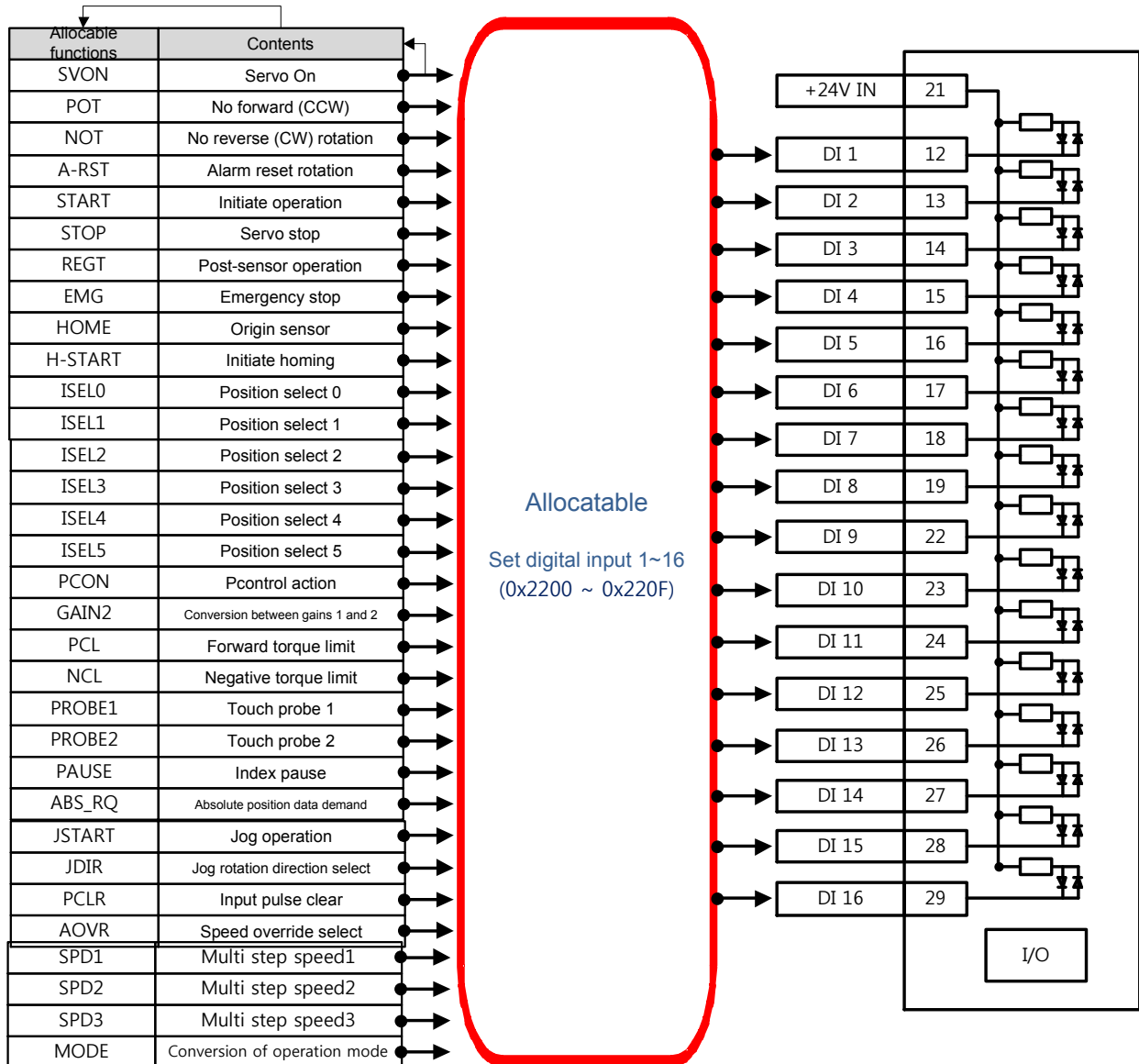

■ Related Objects

Index	Sub Index	Name	Variable Format	Accessibility	PDO Allocation	Unit
0x2200	-	Digital Input Signal 1 Selection	UINT	RW		-
0x2201	-	Digital Input Signal 2 Selection	UINT	RW		-
0x2202	-	Digital Input Signal 3 Selection	UINT	RW		-
0x2203	-	Digital Input Signal 4 Selection	UINT	RW		-
0x2204	-	Digital Input Signal 5 Selection	UINT	RW		-
0x2205	-	Digital Input Signal 6 Selection	UINT	RW		-
0x2206	-	Digital Input Signal 7 Selection	UINT	RW		-
0x2207	-	Digital Input Signal 8 Selection	UINT	RW		-
0x2208	-	Digital Input Signal 9 Selection	UINT	RW		-
0x2209	-	Digital Input Signal 10 Selection	UINT	RW		-
0x220A	-	Digital Input Signal 11 Selection	UINT	RW		-
0x220B	-	Digital Input Signal 12 Selection	UINT	RW		-
0x220C	-	Digital Input Signal 13 Selection	UINT	RW		-
0x220D	-	Digital Input Signal 14 Selection	UINT	RW		-
0x220E	-	Digital Input Signal 15 Selection	UINT	RW		-
0x220F	-	Digital Input Signal 16 Selection	UINT	RW		-

BIT	Details
15	Signal input level setting (0:CONTACT A, 1:CONTACT B)
14~8	Reserved
7~0	Input signal allocated

You can set the functions of digital input signal of I/O connector and input signal level. Choose the signals to allocate with bit 7~0, and set the signal level at bit 15.

Set Value	Allocated Signal
0x00	Not allocated
0x01	POT
0x02	NOT
0x03	HOME
0x04	STOP
0x05	PCON
0x06	GAIN2
0x07	P_CL
0x08	N_CL
0x09	MODE
0x0A	RESERVED
0x0B	EMG
0x0C	A_RST
0x0F	SV_ON
0x10	START

Example) When the set value is 0x0006

0	0	0	6
CONTACT A		GAIN2Allocation	

0x11	PAUSE
0x12	REGT
0x13	HSTART
0x14	ISEL0
0x15	ISEL1
0x16	ISEL2
0x17	ISEL3
0x18	ISEL4
0x19	ISEL5
0x1A	ABSRQ
0x1B	JSTART
0x1C	JDIR
0x1D	PCLR
0x1E	AOVR
0x20	SPD1
0x21	SPD2
0x22	SPD3
0x23	MODE

Contact A: Base status is 0(Low). Activates when input.(Active High)

1(High) is

Contact B: Base status is 1(High). Activates when 0(Low) is input (Active Low)

■ Example of Input SignalAllocation

The table below shows an example of allocating input signals. Please note the set values of 0x2200~0x220F.

DI1	DI2	DI3	DI4	DI 5	DI 6	DI 7	DI 8
SV_ON (CONTACT A)	POT (CONTACT A)	NOT (CONTACT A)	A-RST (CONTACT A)	START (CONTACT A)	STOP (CONTACT A)	REGT (CONTACT A)	EMG (CONTACT A)
DI 9	DI 10	DI 11	DI 12	DI 13	DI 14	DI 15	DI 16
HOME (CONTACT B)	HSTART (CONTACT B)	ISEL0 (CONTACT A)	ISEL1 (CONTACT A)	ISEL2 (CONTACT A)	ISEL3 (CONTACT A)	ISEL4 (CONTACT A)	ISEL5 (CONTACT A)

CN1 (Pin number)	Set parameter	Bit		Set value	Content
		15	7~0		
DI # 1 (12)	0x2200	0	0x0F	0x000F	SV_ON(A CP)
DI # 2 (13)	0x2201	0	0x01	0x0001	POT(A CP)
DI # 3 (14)	0x2202	0	0x02	0x0002	NOT(A CP)
DI # 4 (15)	0x2203	0	0x0C	0x000C	A-RST(A CP)
DI # 5 (16)	0x2204	0	0x10	0x0010	START(A CP)
DI # 6 (17)	0x2205	0	0x04	0x0004	STOP(A CP)
DI # 7 (18)	0x2206	0	0x12	0x0012	REGT(A CP)
DI # 8 (19)	0x2207	0	0x0B	0x000B	EMG(A CP)
DI # 9 (22)	0x2208	1	0x03	0x8003	HOME(B CP)
DI # A (23)	0x2209	1	0x13	0x8013	HSTART(B CP)
DI # B (24)	0x220A	0	0x14	0x0014	ISELO(A CP)
DI # C (25)	0x220B	0	0x15	0x0015	ISEL1(A CP)
DI # D (26)	0x220C	0	0x16	0x0016	ISEL2(A CP)
DI # E (27)	0x220D	0	0x17	0x0017	ISEL3(A CP)
DI # F (28)	0x220E	0	0x18	0x0018	ISEL4(A CP)
DI # 10 (29)	0x220F	0	0x19	0x0019	ISEL5(A CP)

10.2.2 Allocating Digital Output Signals

You can set the functions of digital output signal of I/O connector and output signal level. Among the 19 output functions listed below, you can allocate the functions that you want to use to digital input signals 1 through 8 at your discretion.

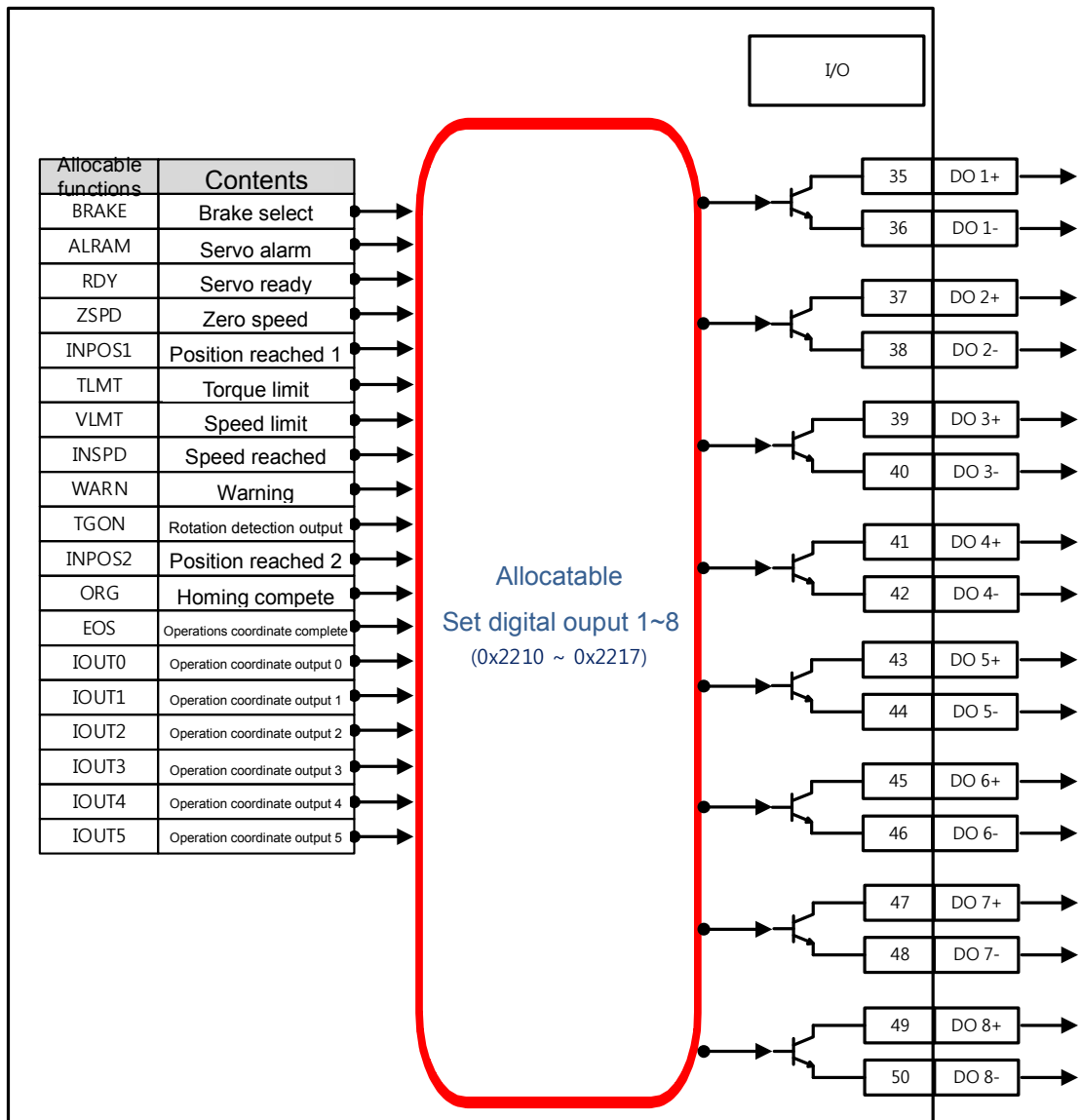

■ Related Objects

Index	Sub Index	Name	Variable Format	Accessibil ity	PDO Allocati on	Unit
0x2210	-	Digital Output Signal 1 Selection	UINT	RW		-
0x2211	-	Digital Output Signal 2 Selection	UINT	RW		-
0x2212	-	Digital Output Signal 3 Selection	UINT	RW		-
0x2213	-	Digital Output Signal 4 Selection	UINT	RW		-
0x2214	-	Digital Output Signal 4 Selection	UINT	RW		-
0x2215	-	Digital Output Signal 4 Selection	UINT	RW		-
0x2216	-	Digital Output Signal 4 Selection	UINT	RW		-
0x2217	-	Digital Output Signal 4 Selection	UINT	RW		-

You can set the output signal level by allocating functions of digital output signals of I/O connector. Choose the signals to allocate with bit 7~0, and set the signal level at bit 15.

Bit	Details
15	Signal output level setting (0:CONTACT A, 1:CONTACT B)
14~8	Reserved
7~0	Allocated output signal

Set Value	Allocatable Output Signals
0x00	Not Allocated
0x01	BRAKE
0x02	ALARM
0x03	RDY
0x04	ZSPD
0x05	INPOS1
0x06	TLMT
0x07	VLMT
0x08	INSPD
0x09	WARN
0x0A	TGON
0x0B	INPOS2
0x10	ORG
0x11	EOS
0x12	IOUT0
0x13	IOUT1
0x14	IOUT2
0x15	IOUT3
0x16	IOUT4
0x17	IOUT5

■ Example of Digital Output Allocation

The table below shows an example of allocating input signals. Please note the set values of 0x2210~0x2217.

DO#1	DO#2	DO#3	DO#4	DO#5	DO#6	DO#7	DO#8
ALARM (CONTACT B)	RDY (CONTACT A)	BRAKE (CONTACT B)	INPOS1 (CONTACT A)	ORG (CONTACT A)	EOS (CONTACT A)	TGON (CONTACT A)	TLMT (CONTACT A)

CN1 Pin number	Set parameter	Bit		Set value	Content
		15	7~0		
DO # 1 (35,36)	0x2210	1	0x02	0x8002	ALARM (Contact B)
DO # 2 (37,38)	0x2211	0	0x03	0x0003	RDY (Contact A)
DO # 3 (39,40)	0x2212	1	0x01	0x8001	BRAKE (Contact B)
DO # 4 (41,42)	0x2213	0	0x05	0x0005	INPOS1 (Contact A)
DO # 5 (43,44)	0x2214	0	0x10	0x0010	ORG (Contact A)
DO # 6 (45,46)	0x2215	0	0x11	0x0011	EOS (Contact A)
DO # 7 (47,48)	0x2216	0	0x0A	0x000A	TGON (Contact A)
DO # 8 (49,50)	0x2217	0	0x06	0x0006	TLMT (Contact A)

10.2.3 Using User I/O

User I/O refers to a portion of I/S provided by the drive used for user's purposes other than the purpose of controlling the drive. All contacts provided through I/O connector can be used as User I/O.

If the number of User I/O required is small, you can use the drive's I/O connector instead of using additional I/O modules, resulting in cost reduction.

This drive provides up to 16 input signals and 8 output signals as user I/O.

■ How to set user input

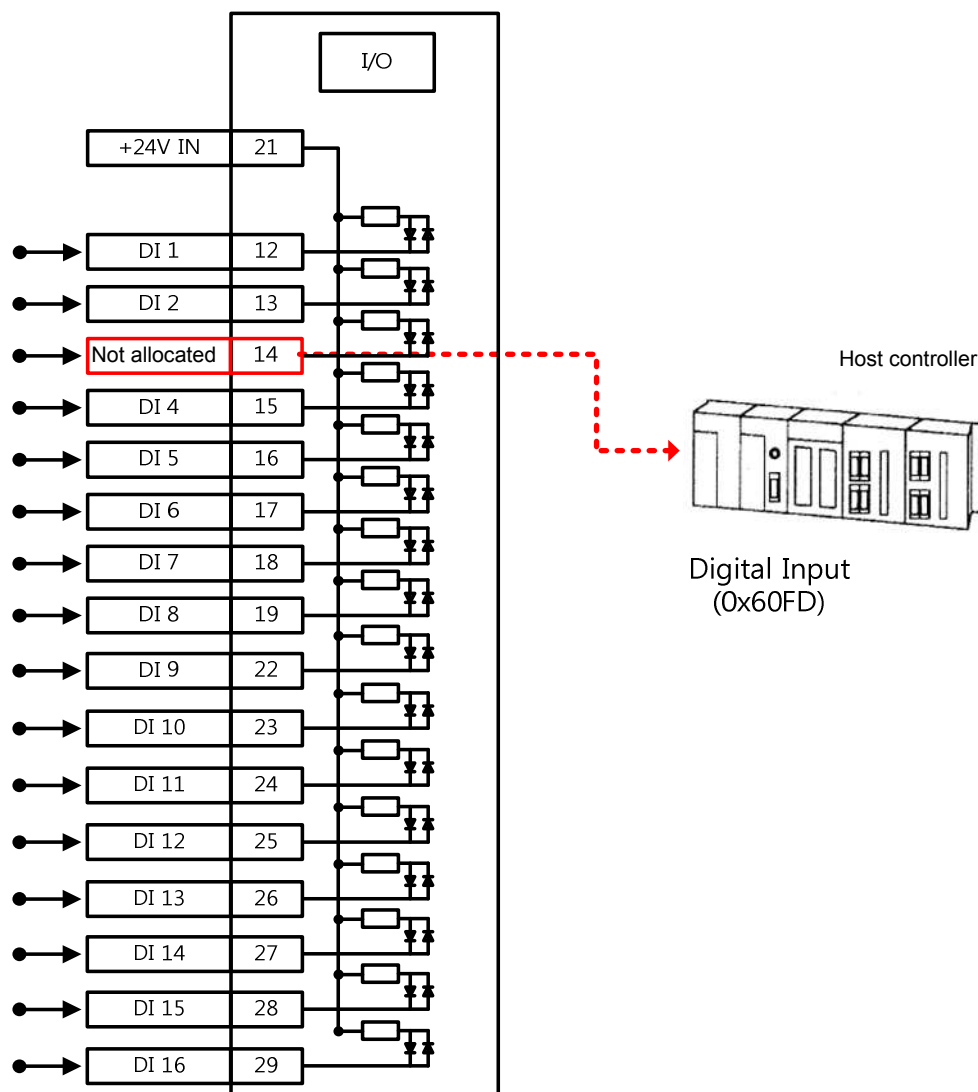

- 1) Set the function of the digital input port to use as user input to "Not Allocated (Set Value 0)". (See Allocating Input Signal)
- 2) The values of relevant bits (0x60FD.16~31) are read from digital input, to use as user input.

■ Related Objects

Index	Sub Index	Name	Variable Format	Accessibility	PDO Allocation	Unit
0x60FD	-	(Digital Inputs	UDINT	RO	Yes	-

bit	Descriptions
0	NOT(negative limit switch)
1	POT(positive limit switch)
2	HOME(origin sensor)
3 to 15	Reserved
16	DI#1(I/O pin 12), 0:Open, 1:Close
17	DI #2(I/O pin 13), 0:Open, 1:Close
18	DI #3(I/O pin 14), 0:Open, 1:Close
19	DI#4(I/O pin 15), 0:Open, 1:Close
20	DI #5(I/O pin 16), 0:Open, 1:Close
21	DI #6(I/O pin 17), 0:Open, 1:Close
22	DI #7(I/O pin 18), 0:Open, 1:Close
23	DI #8(I/O pin 19), 0:Open, 1:Close
24	DI #9(I/O pin 22), 0:Open, 1:Close
25	DI #A(I/O pin 23), 0:Open, 1:Close
26	DI #B(I/O pin 24), 0:Open, 1:Close
27	DI #C(I/O pin 25), 0:Open, 1:Close
28	DI #D(I/O pin 26), 0:Open, 1:Close
29	DI #E(I/O pin 27), 0:Open, 1:Close
30	DI #F(I/O pin 28), 0:Open, 1:Close
31	DI #10(I/O pin 29), 0:Open, 1:Close

■ How to set user output

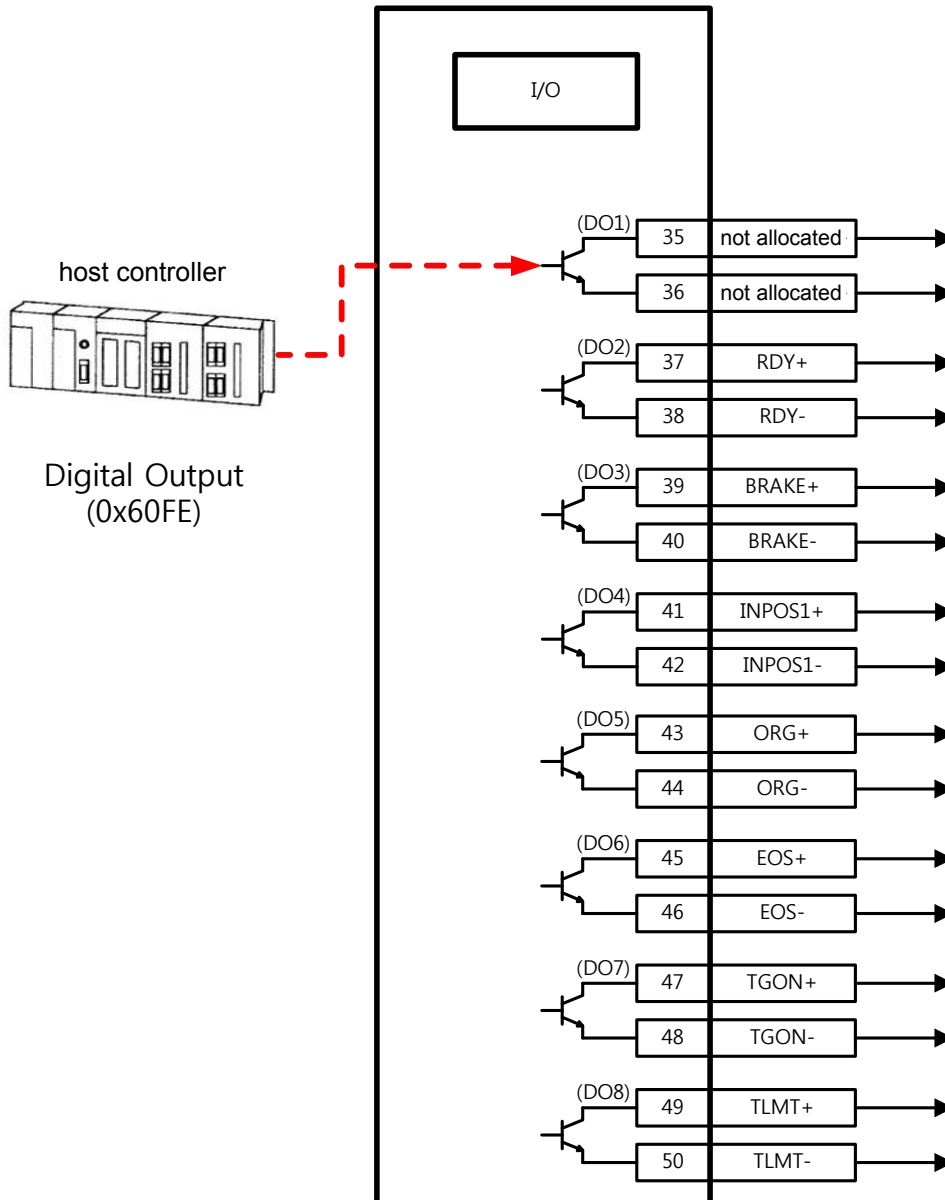

- 1) Set the function of the digital output port to use as user input to "Not Allocated (Set Value 0)". (See Allocating Input Signal)
- 2) At the Bit Mask (0x60FE:02), set the bit corresponding to the port to use as user output (bit 16~23) to 'Enable Forced Output' (Set Value: 1)
- 3) Using physical outputs(0x60FE:01), set the value corresponding to user output to 0 or 1, at the relevant port (bit 16~23)

■ Related Objects

Index	Sub Index	Name	Variable Format	Accessibility	PDO Allocation	Unit
0x60FE	-	Digital Outputs	-	-	-	-
	0	Number of entries	USINT	RO	No	
	1	Physical outputs	UDINT	RW	Yes	-
	2	Bit mask	UDINT	RW	No	-

It displays digital output status.

- Physical outputs descriptions

Bit	Description
0 to 15	Reserved
16	Forced output of DO#1(I/Opin 35, 36)(0:OFF, 1:ON) Provided that the relevant bit mask (0x60FE:02.16) is set to 1
17	Forced output of DO#1(I/Opin 37, 38) (0:OFF, 1:ON) Provided that the relevant bit mask (0x60FE:02.17) is set to 1
18	Forced output of DO#1(I/Opin 39, 40) (0:OFF, 1:ON) Provided that the relevant bit mask (0x60FE:02.18) is set to 1
19	Forced output of DO#1(I/Opin 41, 42) (0:OFF, 1:ON) Provided that the relevant bit mask (0x60FE:02.19) is set to 1
20	Forced output of DO#1(I/Opin 43, 44) (0:OFF, 1:ON) Provided that the relevant bit mask (0x60FE:02.20) is set to 1
21	Forced output of DO#1(I/Opin 45, 46) (0:OFF, 1:ON) Provided that the relevant bit mask (0x60FE:02.21) is set to 1
22	Forced output of DO#1(I/Opin 47, 48) (0:OFF, 1:ON) Provided that the relevant bit mask (0x60FE:02.22) is set to 1
23	Forced output of DO#1(I/Opin 49, 50) (0:OFF, 1:ON) Provided that the relevant bit mask (0x60FE:02.23) is set to 1
24	DO #1output status (0:OFF, 1:ON)
25	DO #2output status (0:OFF, 1:ON)
26	DO #3 output status (0:OFF, 1:ON)
27	DO #4output status (0:OFF, 1:ON)
28	DO #5output status (0:OFF, 1:ON)
29	DO #6output status (0:OFF, 1:ON)
30	DO #7output status (0:OFF, 1:ON)
31	DO #8output status (0:OFF, 1:ON)

- Bit mask descriptions

Bit	Descriptions
0 to 15	Reserved
16	DO#1(I/O pin 35, 36)output status setting (0:Disable, 1:Enable)
17	DO#2(I/O pin 37, 38)output status setting (0:Disable, 1:Enable)
18	DO #3(I/O pin 39, 40)output status setting (0:Disable, 1:Enable)
19	DO #4(I/O pin 41, 42)output status setting (0:Disable, 1:Enable)
20	DO#1(I/O pin 43, 44)output status setting (0:Disable, 1:Enable)
21	DO#2(I/O pin 45, 46)output status setting (0:Disable, 1:Enable)
22	DO #3(I/O pin 47, 48)output status setting (0:Disable, 1:Enable)
23	DO #4(I/O pin 49, 50)output status setting (0:Disable, 1:Enable)
24 to 31	Reserved

10.3 Electronic Gear Setting

10.3.1 Electronic Gear

This function allows the user to rotate the motor by the minimum unit that the user wants to command (User Unit).

Using the drive's electronic gear function prohibits maximizing the use of the encoder's resolution. Therefore, if the host device has an electronic gear function, we recommend using the host device.

Please set the gear ratio between 1000~1/1000

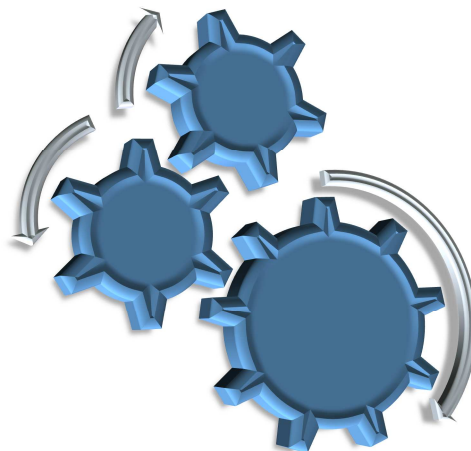

Electronic gears are generally used for the following purposes.

(1) When driving loads based on the user unit.

- You can give command based on the user unit, regardless of the encoder (motor) type. The table below shows comparison between 5000ppr encoder and 19bit encoder, when moving 12mm using the same 10mm-pitch ball screw.

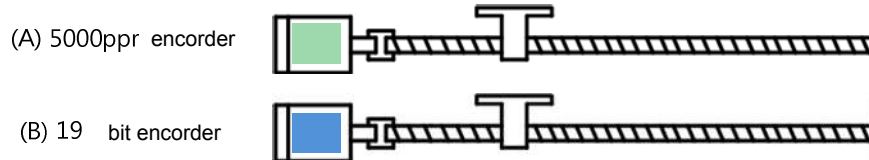

	(A) 5000ppr Encoder	(B) 19bit (524288 ppr) Encoder
Without electronic gear	$5000 \times 12 / 10 = 6000$	$524288 \times 12 / 10 = 629145.6$
	Different commands should be given to each encoder (motor) when moving the same distance	
<u>When giving command based on the minimum unit (user unit) of 1um(0.001mm)</u>		
Electronic gear setting	Motor Revolutions = 5000 Shaft Revolutions = 10000	Motor Revolutions = 524288 Shaft Revolutions = 10000
With electronic gear	You can give the same command to move 12000(12mm= 12000*1um) regardless of the encoder (motor) type.	

(2) When the output frequency of the host device and the drive's input frequency are restricted when driving a high-resolution encoder at a high speed

- A regular high-speed line drive pulse output unit has output frequency of around 500Kpps. The drive's input frequency is around 1~4Mpps. For this reason, driving a high-resolution encoder at a high speed restricts the output frequency of the host device and the drive's input frequenc. Electronic gears must be used to achieve normal driving.

10.3.2 Examples of Electronic Gear Setting

■ Ball Screw Load

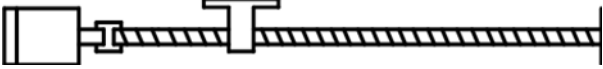
Unit Specifications	 <p>Pitch: 10mm, Deceleration ratio:1/1</p>
User Unit	1 μ m(0.001mm)
Encoder Specifications	19bit(524288 PPR)
Load Movement / 1 revolution	10[mm] = 10000[User Unit]
Electronic Gear setting	Motor Revolutions : 524288 Shaft Revolutions : 10000

■ Truntable Load

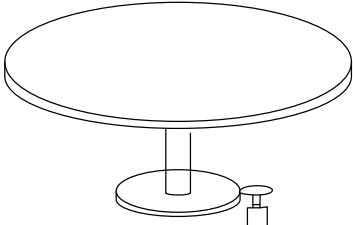
Unit Specifications	 <p>Deceleration ratio:100/1</p>
User Unit	0.001°
Encoder Specifications	19bit(524288 PPR)
Load Movement / 1 revolution	$360/100/0.001=3600$
Electronic Gear setting	Motor Revolutions : 524288 Shaft Revolutions : 3600

■ Belt + Pulley System

Unit Specifications	 <p>Deceleration ratio:10/1, Pulley diameter:100mm</p>
User Unit	1 μ m(0.001mm)
Encoder Specifications	19bit(524288 PPR)
Load Movement / 1 revolution	$\pi*100/10/0.001=31416$
Electronic Gear setting	Motor Revolutions : 524288 Shaft Revolutions : 31416

10.4 Settings Related with Speed Control

10.4.1 Smooth Acceleration/Deceleration

For smooth acceleration/deceleration during speedcontrol, you can operate the motor by creating acceleration/deceleration profile in trapezoidal and s-curve shapes. In addition, you can perform s-curve operation by setting the speedcommand s-curve time to 1[ms] or more.

The speedcommand acceleration/deceleration time (0x2301, 0x2302) is the time it takes to accelerate to the rated speed or decelerate from the rated speed to full stop. (See the figure below)

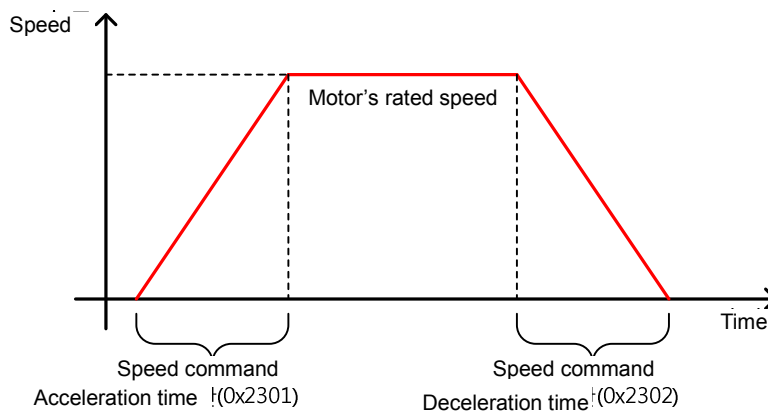

The actual acceleration/deceleration time can be calculated as follows.

Acceleration time = speedcommand / rated speed x speedcommand deceleration time (0x2301)

Deceleration time = speedcommand / rated speed x speedcommand acceleration time (0x2302)

As shown in the figure below, you can operate the machine by creating a S-curve acceleration/deceleration profile by setting the speedcommand s-curve time to 1[ms] or more. Please note the relationship between acceleration/deceleration time and S-curve time.

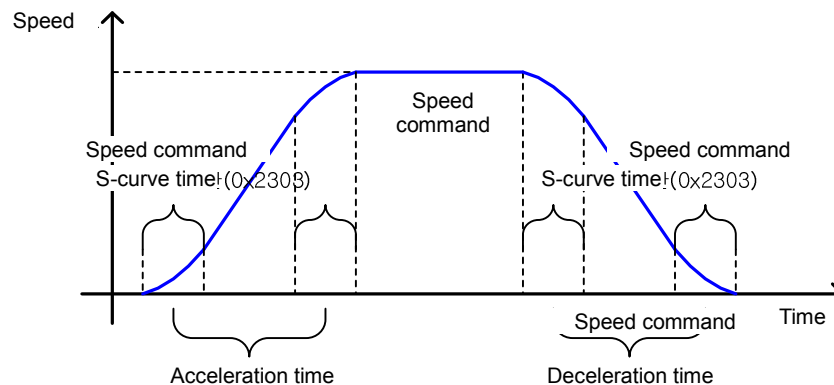

10.4.2 Servo-lock Function

When controlling speed, the servo's position is not locked even when the speed command is 0. This is due to the characteristic of speed control. By setting the servo-lock function (0x2311), you can lock the servo position.

Set Value	Details
0	Servo-lock function not used
1	Servo-lock function used

When using the servo-lock function, the position is internally control based on the position at the time when the speed command is input as 0. When the speed command is not 0, the control is changed into normal speed.

10.4.3 Signals Related with Speed Control

As shown in the figure below, when the value of the speed feedback goes under the ZSPD output range (0x2404), the ZSPD (0 speed) signal is displayed. If the value goes over the TGON output range (0x2405), the TGON (motor revolution) signal is displayed.

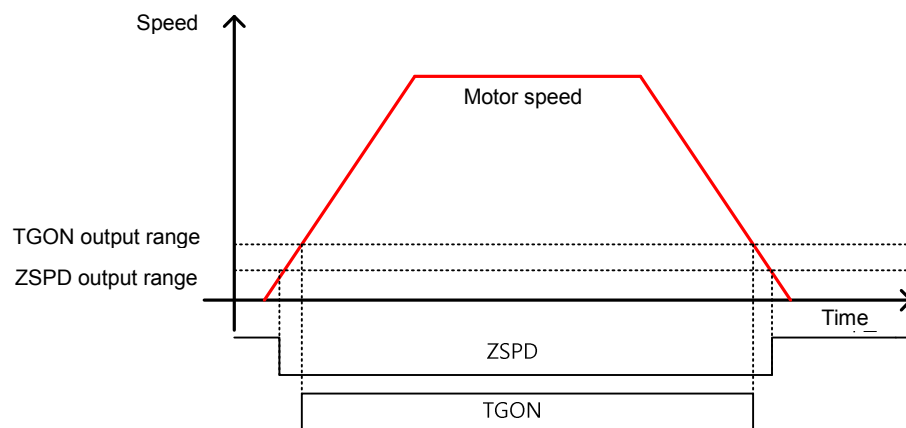

And when the difference between the command and the speed feedback, that is, the speed error is within the INSPD output range (0x2406), the INSPD(speed match) signal is displayed.

■ Related Objects

Index	Sub Index	Name	Variable Format	Accessibility	PDO Allocation	Unit
0x2404	-	ZSPD Ouput Range	UINT	RW	Yes	rpm
0x2405	-	TGON Ouput Range	UINT	RW	Yes	rpm
0x2406	-	INSPD Ouput Range	UINT	RW	Yes	rpm

10.5 Settings Related with Position Control

10.5.1 Position Command Filter

You can apply filters to position command to achieve smoother operation. For such filtering, you can set the position command filter time constant using the primary low pass filter (0x2109) and the position command average filter time constant using movement average (0x210A).

Position command filter can be used in the following cases.

- (1) Cases where the electronic gear ratio is 10 times or higher
- (2) Cases where the host device cannot create acceleration/deceleration profile.

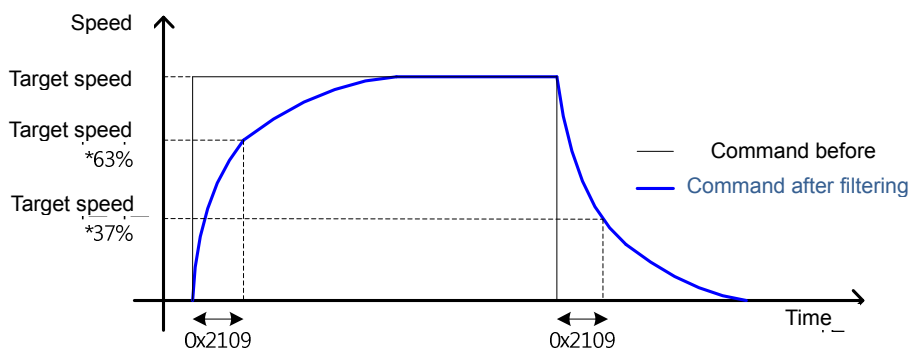

Position command filter using the position command filter time constant (0x2109)

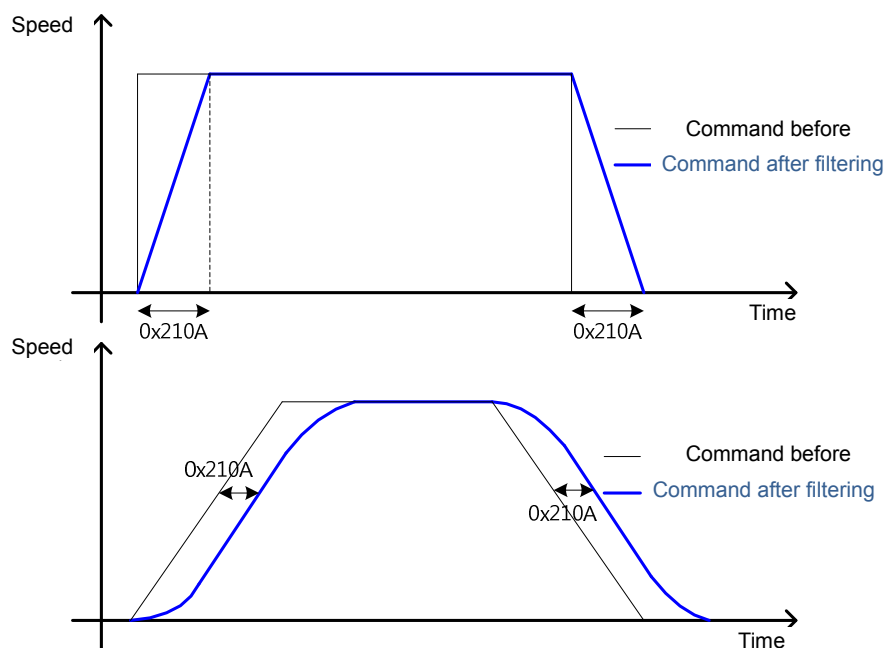

Position command filter using position command average filter time constant (0x210A)

■ Related Objects

Index	Sub Index	Name	Variable Format	Accessibility	PDO Allocation	Unit
0x2109	-	Position Command Filter Time Constant	UINT	RW	Yes	0.1ms
0x210A	-	Position Command Average Filter Time Constant	UINT	RW	Yes	0.1ms

10.5.2 Signals Related with Position Control

As shown in the figure below, the difference between the position command value from the host controller and the position feedback value, that is the position error, is under the INPOS1 output range (0x2401) and is maintained for the duration of INPOS1 output time(0x2402), the INPOS1(In Position 1) signal is displayed. However, the INPOS1 signal is displayed only when the position command is not updated.

In addition, regardless whether the position command is updated, the INPOS2 (In Position 2) signal is displayed when the position error is below the INPOS2 output range (0x2403)..

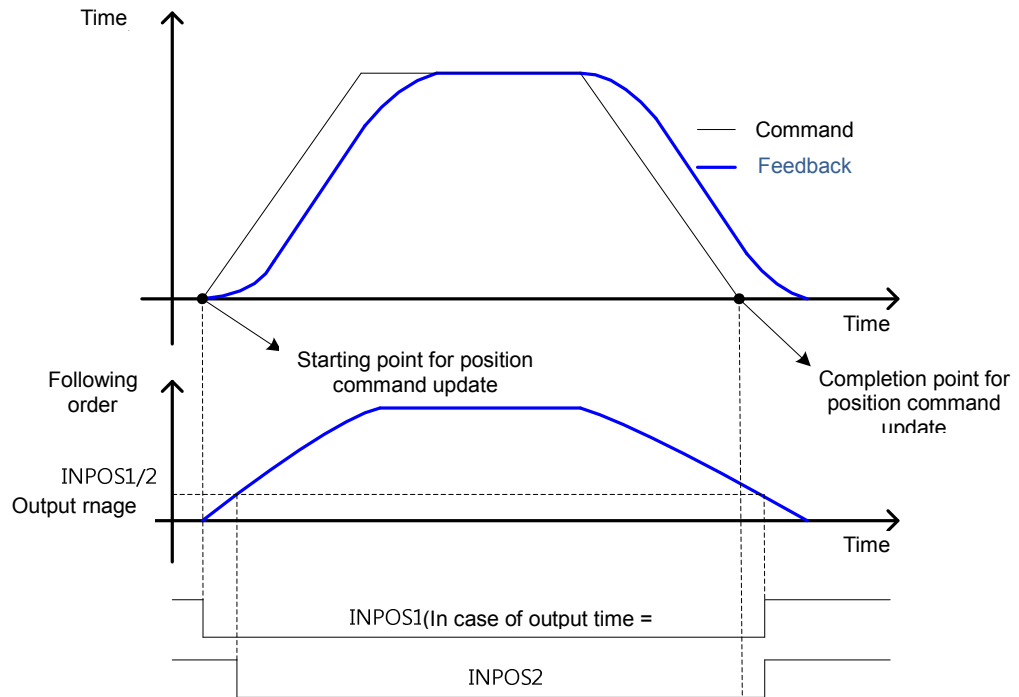

■ Related Objects

Index	Sub Index	Name	Variable Format	Accessibility	PDO Allocation	Unit
0x2401	-	INPOS1 Output Range	UINT	RW	Yes	UU
0x2402	-	INPOS1 Output Time	UINT	RW	Yes	ms
0x2403	-	INPOS2 Output Range	UINT	RW	Yes	UU

10.6 Forward/Reverse Limit Setting

This function allows you to safely operate the motor within the movement range of the unit, using the drive's forward and reverse limit signals. Please make sure to connect and set the limit switch for safer operation. Please see 『5.2.1 Allocating Digital Input Signal』 for setting instructions.

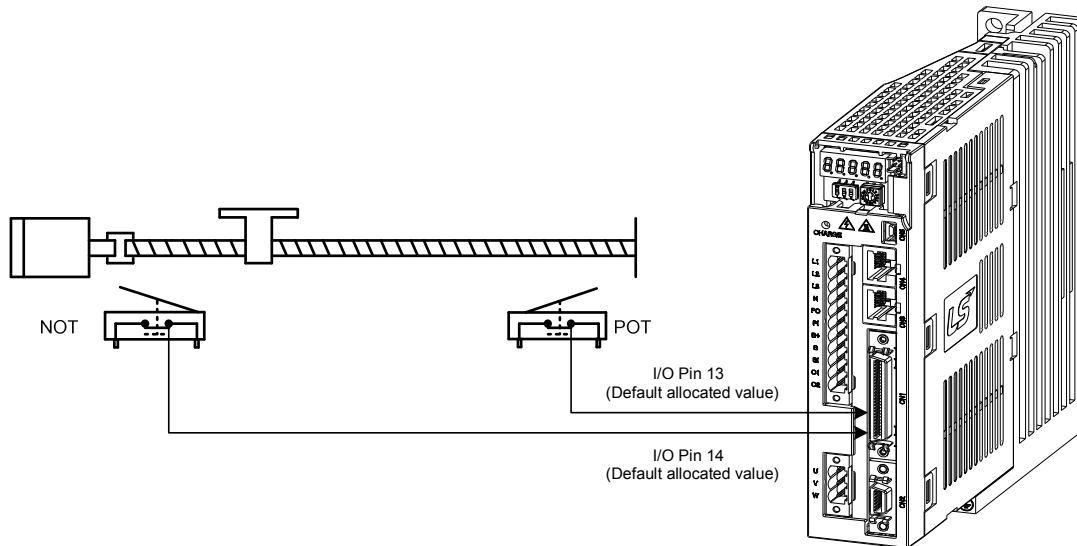

When forward/reverselimit signal is input, you can stop the motor using the emergency stop setting (0x2013).

Set Value	Decriptions
0	Stop the motor following the method selected at the dynamic brake control mode (0x2012) Stop the motor using the dynamic brake, and maintain the torque command at 0
1	Decelerate and stop using the emergency stop torque (0x2113)

■ Related Objects

Index	Sub Index	Name	Variable Format	Accessibility	PDO Allocation	Unit
0x2012	-	Dynamic Brake Control Mode	UINT	RW	No	-
0x2013	-	Emergency Stop Configuration	UINT	RW	No	-
0x2113	-	(Emergency Stop Torque	UINT	RW	Yes	-

10.7 Brake Output Signal Function Setting

If the motor is stopped by servo off or servo alarm, you can set the output timing by setting the brake signal output speed (0x2407) and the delay time (0x2408).

When the motor's revolution speed is under the set speed (0x2407) or the output delay time (0x2408) lapses after servo off command, brake signal is output.

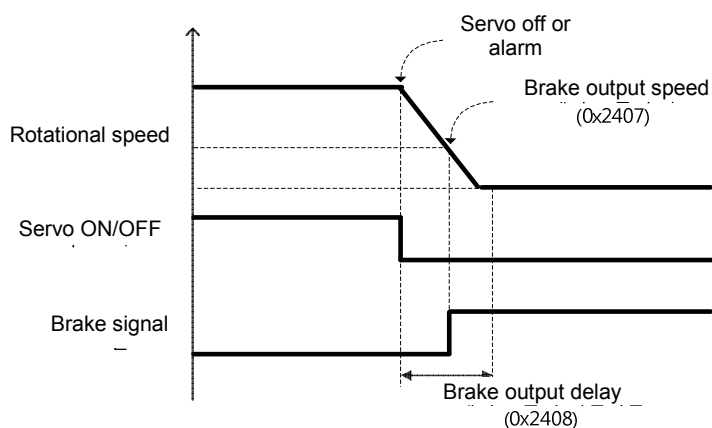

Timing diagram of signal output by brake output speed (0x2407)

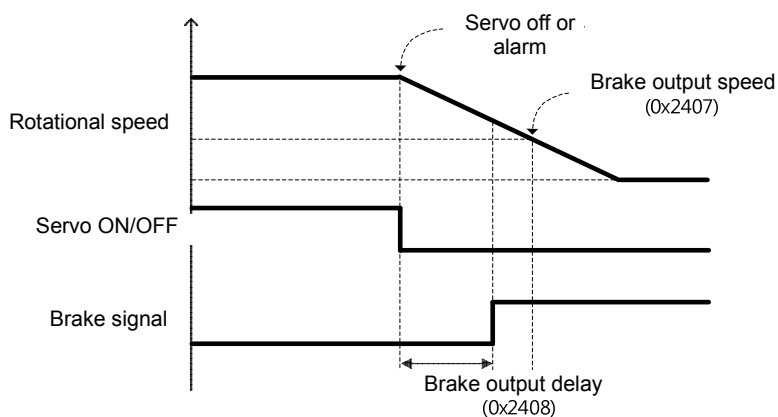

Timing diagram of signal output by brake output delay time (0x2408)

You can set the time of delay until the actual PWM output is off when the servo is off or the servo alarm is set off.

When using a motor with the brake equipped at the vertical shaft, you can prevent slipping in the vertical direction by first outputting the brake signal and turning off PWM after the set time.

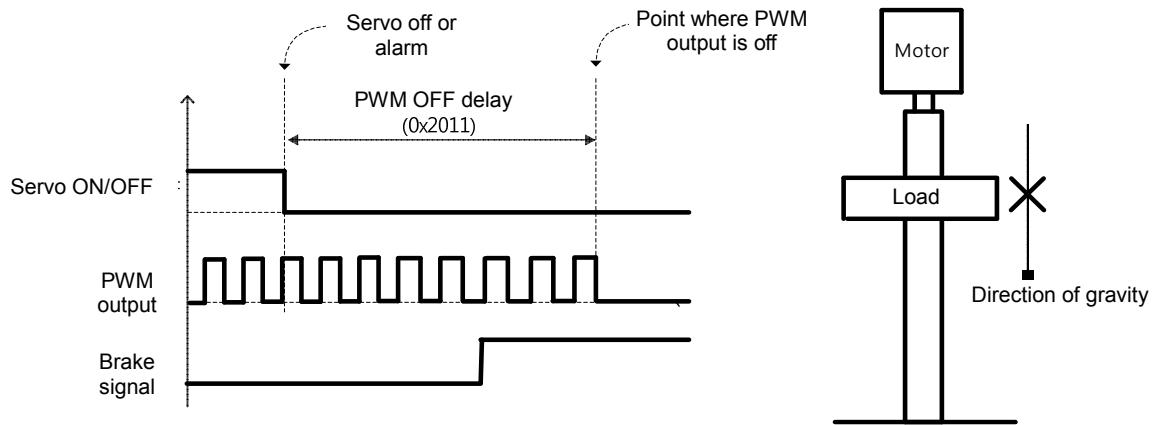

(1) Cases where the brake signal is first output and the PWM output is turned off.

You can prevent vertical fall caused by the gravity by outputting the brake signal before turning off the PWM output.

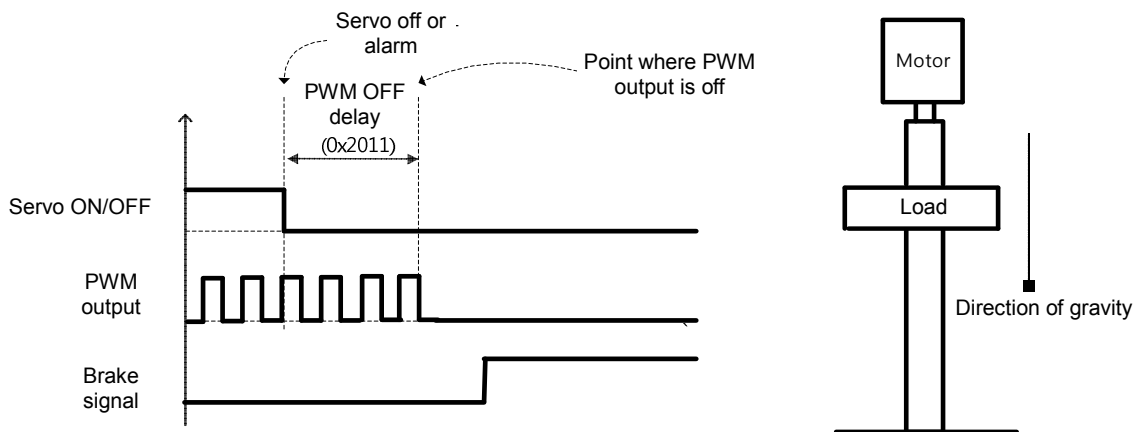

(2) Cases where the PWM is turned off before the brake signal is output.

When the PWM output is turned off before the brake signal output, the load falls in the vertical direction, pulled down by the gravity.

10.8 Torque Limit Function

You can limit the drive's output torque to protect the machine. You can limit the output torque by setting the torque limit function (0x2110). The torque limit unit is [0.1%].

- Torque limit function setting (0x2110) description

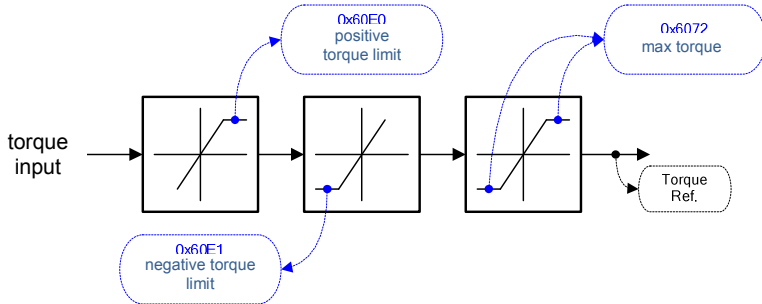
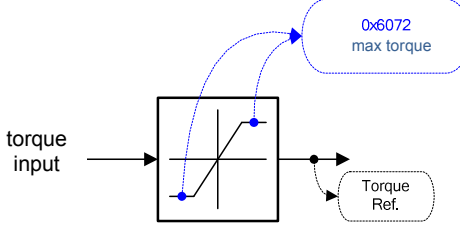
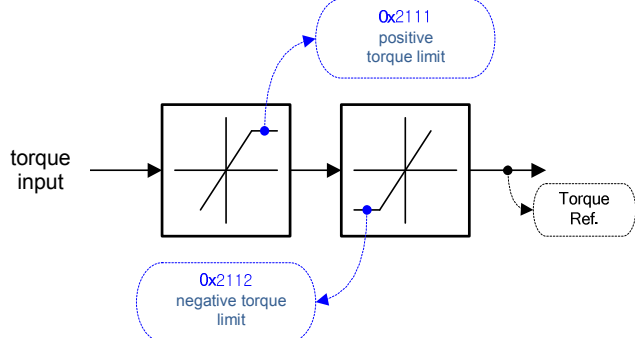
Limit Function	Descriptions
<p>Internal Torque Limit 1 (Set Value 0)</p>	 <p>Torque is limited using the forward/negative torque limit value depending on the direction of rotation. The maximum value is limited by the maximum torque(0x6072)</p> <p>- Forward: 0x60E0, B Torque is limited using the forward/negative torque limit value depending on the direction of rotation. ackward: 0x60E1</p>
<p>Internal Torque Limit 2 (Set Value 1)</p>	 <p>The torque is limited only by the maximum torque (0x6072) regardless of the direction</p>
<p>External Torque Limit (Set Value 2)</p>	 <p>Torque is limited using the external positive/negative torque limit value depending on the direction of rotation.</p> <p>- Forward: 0x2111, Reverse: 0x2112</p>

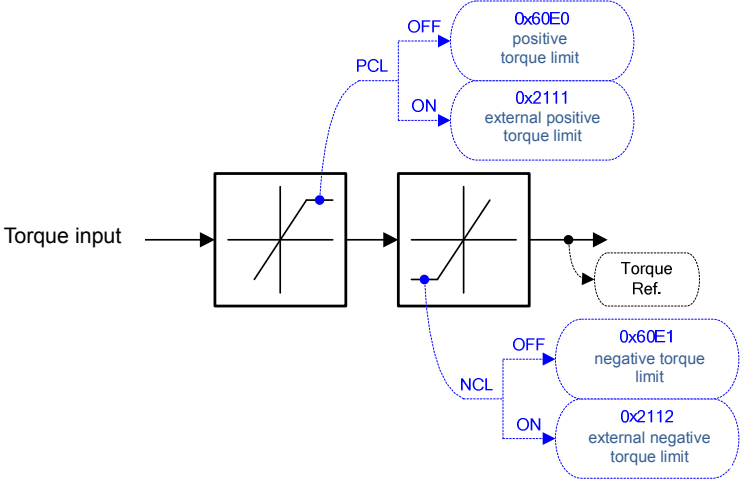
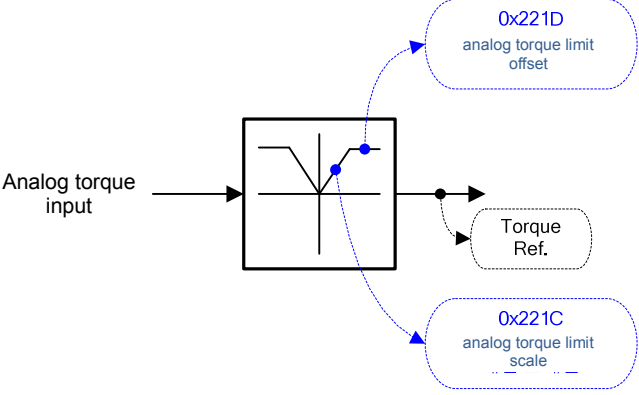
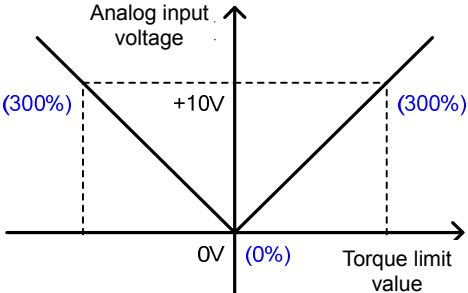
<p>Internal+External Torque Limit (Set Value 3)</p>	 <p>Torque is limited using the internal and external positive/negative torque limit value depending on the direction of rotation and torque limit signal.</p> <ul style="list-style-type: none"> - Forward: 0x60E0(PCL without signal input), 0x2111(with PCL signal input) - Reverse: 0x60E1(NCL without signal input), 0x2112(with NCL signal input)
<p>Analog Torque Limit (Set Value 4)</p>	 <p>The torque is limited using the torque limit value depending on the analog input voltage.</p> <ul style="list-style-type: none"> - Regardless of the positivity/negativity of analog input voltage, when inputting +/-10[V], the torque is limited in the forward/reverse direction with 300[%]torque - The relationship between analog input voltage and torque limit is as follows. 

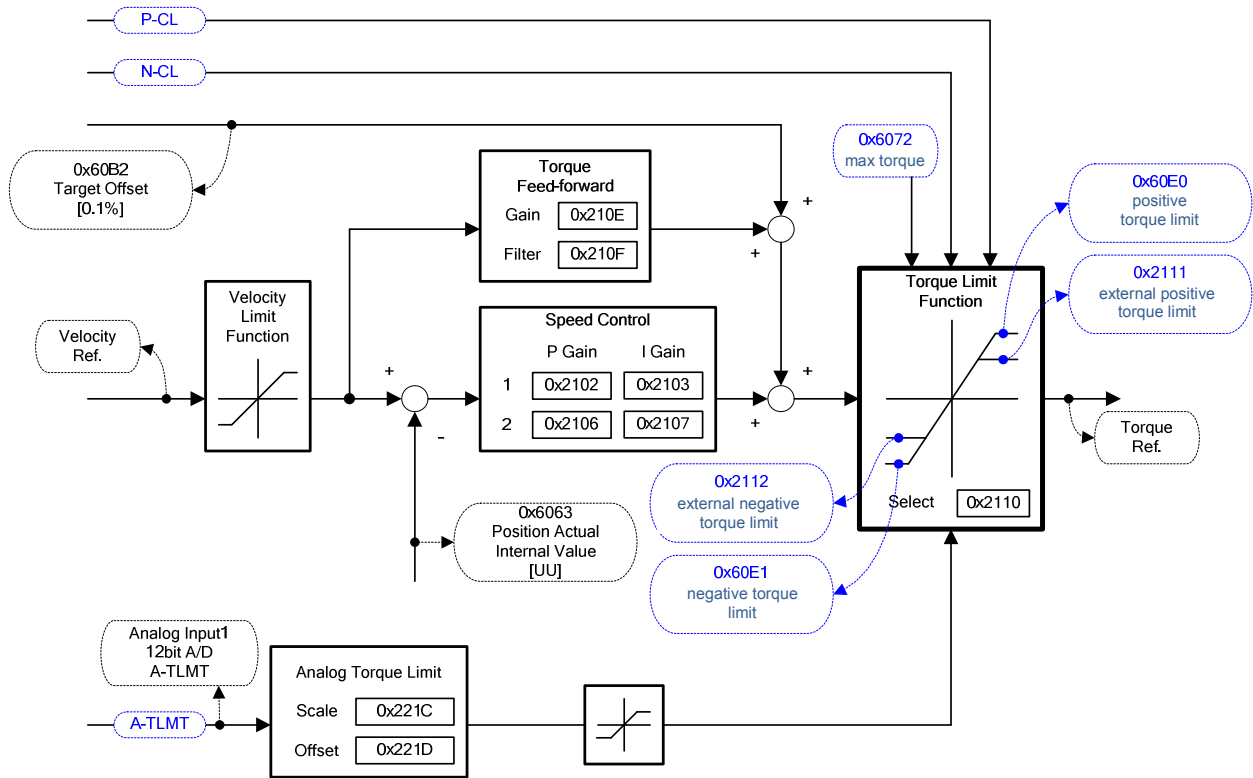

Related Objects

Index	Sub Index	Name	Variable Format	Accessibility	PDO Allocation	Unit
0x2110	-	Torque Limit Function Select	UINT	RW	Yes	-
0x2111	-	External Positive Torque Limit Value	UINT	RW	Yes	0.1%
0x2112	-	External Negative Torque Limit Value	UINT	RW	Yes	0.1%
0x6072	-	Maximum Torque	UINT	RW	Yes	0.1%
0x60E0	-	Positive Torque Limit Value	UINT	RW	Yes	0.1%
0x60E1	-	Negative Torque Limit Value	UINT	RW	Yes	0.1%

10.9 Gain Conversion

10.9.1 Gain Group Conversion

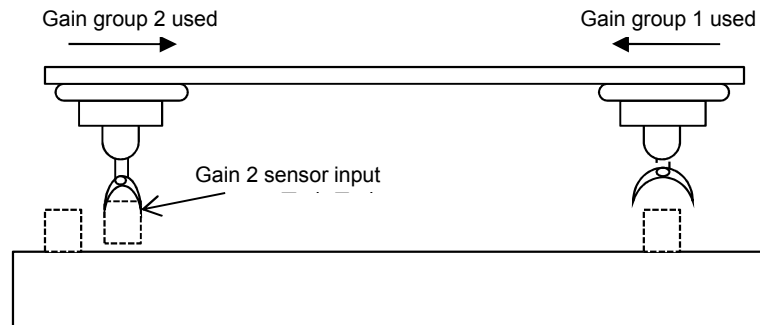

This function is one of the methods to adjust gains: you can convert gain group 1 and gain group 2. Through such conversion, you can reduce the time required for position determination.

Gain group consists of position loop gain / speed loop gain / speed loop integral time constant / torque command filter time constant: you can set the gain conversion function (0x2119) as follows.

- Gain conversion (0x2119) descriptions

Set Value	Details
0	Use only gain group 1
1	Use only gain group 2
2	Gain conversion based on GAIN2 input status - 0: use gain group 1 - 1: use gain group 2
3	Reserved
4	Reserved
5	Reserved
6	Gain conversion based on ZSPD output status - 0: use gain group 1 - 1: use gain group 2
7	Gain conversion based on INPOS1 output status - 0: use gain group 1 - 1: use gain group 2

The waiting time and conversion time during gain conversion are as follows.

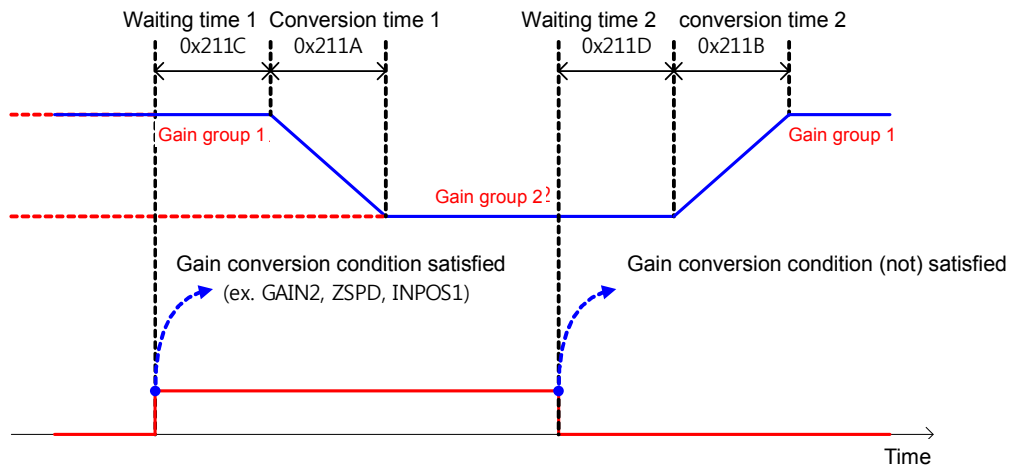
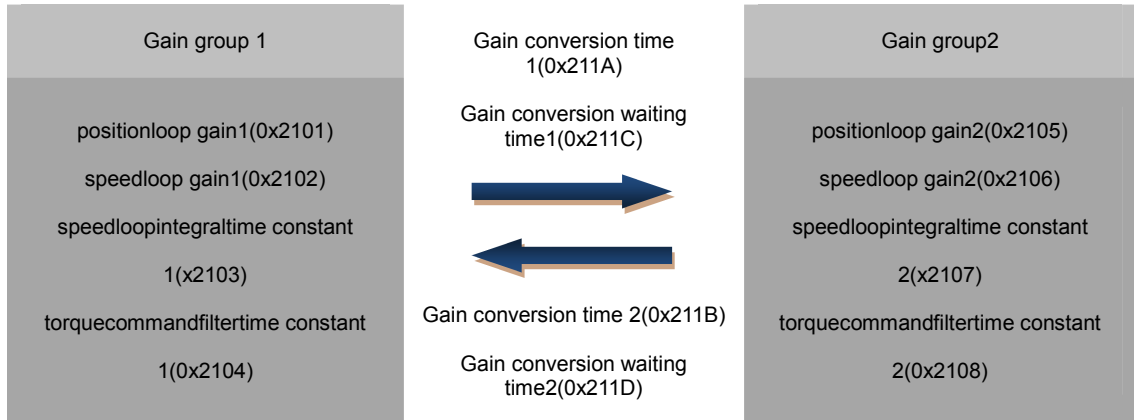

■ Related Objects

Index	Sub Index	Name	Variable Format	Accessibility	PDO Allocation	Unit
0x2119	-	Gain Conversion Mode	UINT	RW	Yes	-
0x211A	-	Gain Conversion Time 1	UINT	RW	Yes	ms
0x211B	-	Gain Conversion Time 2	UINT	RW	Yes	ms
0x211C	-	Gain Conversion Waiting Time 1	UINT	RW	Yes	ms
0x211D	-	Gain Conversion Waiting Time 2	UINT	RW	Yes	ms

10.9.2 P/PI Control Conversion

PI control uses both proportion (P) gain and interal (I) gain of the speed controller. P control refers to control using only proportion gain.

Proportion gain determines the responsivity of the overall controller, and the integral gain is used to remove the error of the steady state. Excessive integral gain leads to overshoot during acceleration/deceleration.

PI/P control conversion function involves covering between PI control and P control, based on the parameter conditions inside the servo (torque,speed,acceleration,position difference).

Speedcontrol: to inhibit overshoot / undershoot during acceleration/deceleration

Positioncontrol: to reduce position determination time by inhibiting undershoot during determination action.

Similar effect can be achieved by acceleration/decelerationsetting at the host device, soft start setting of the servo drive, and positioncommandfilter, etc.

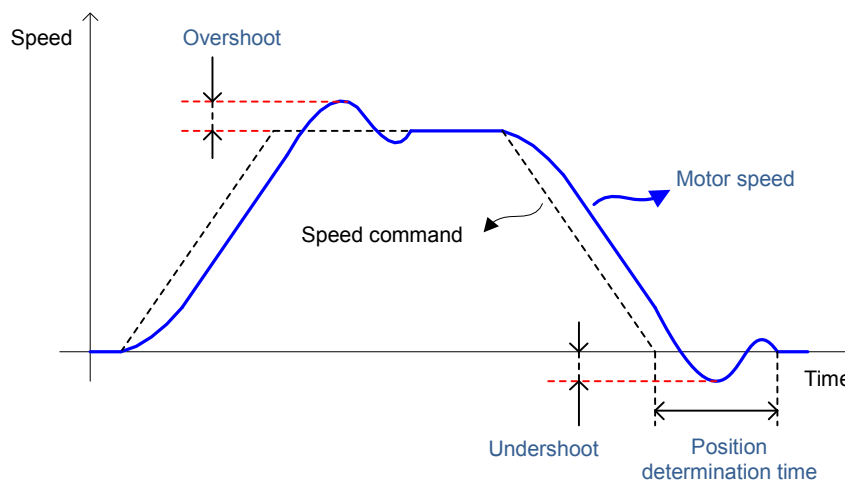

You can set this function by P/PI control conversion mode (0x2114). Please see the explanation below. Conversion to P control by PCON input is given priority over the set value herein.

Set Value	Details
0	PI control at all times
1	Convert to P control when the commandtorque is over the P control switch torque(0x2115)
2	Convert to P control when the commandspeed is over the P control switch speed(0x2116)
3	Convert to P control when the acceperation command is over the P control switch speed(0x2117)
4	Convert to P control when the following error is over the P control switch following error(0x2117)

■ Related Objects

Index	Sub Index	Name	Variable Format	Accessibility	PDO Allocation	Unit
0x2114	-	P/PI Control Conversion Mode	UINT	RW	Yes	-
0x2115	-	P Control Switch Torque	UINT	RW	Yes	0.1%
0x2116	-	P Control Switch Speed	UINT	RW	Yes	rpm
0x2117	-	P Control Switch Acceleration	UINT	RW	Yes	rpm/s
0x2118	-	P Control Switch Following Error	UINT	RW	Yes	pulse

■ Example of P/PI conversion by torquecommand

Using PI control at all times without using P/PI conversion during speed control results in accumulation of the integral term during acceleration/deceleration, which in turn results in overshoot and longer position determination time. By using appropriate P/PI conversion mode, you can reduce the determination time. The figure below shows an example of conversion mode by torque command.

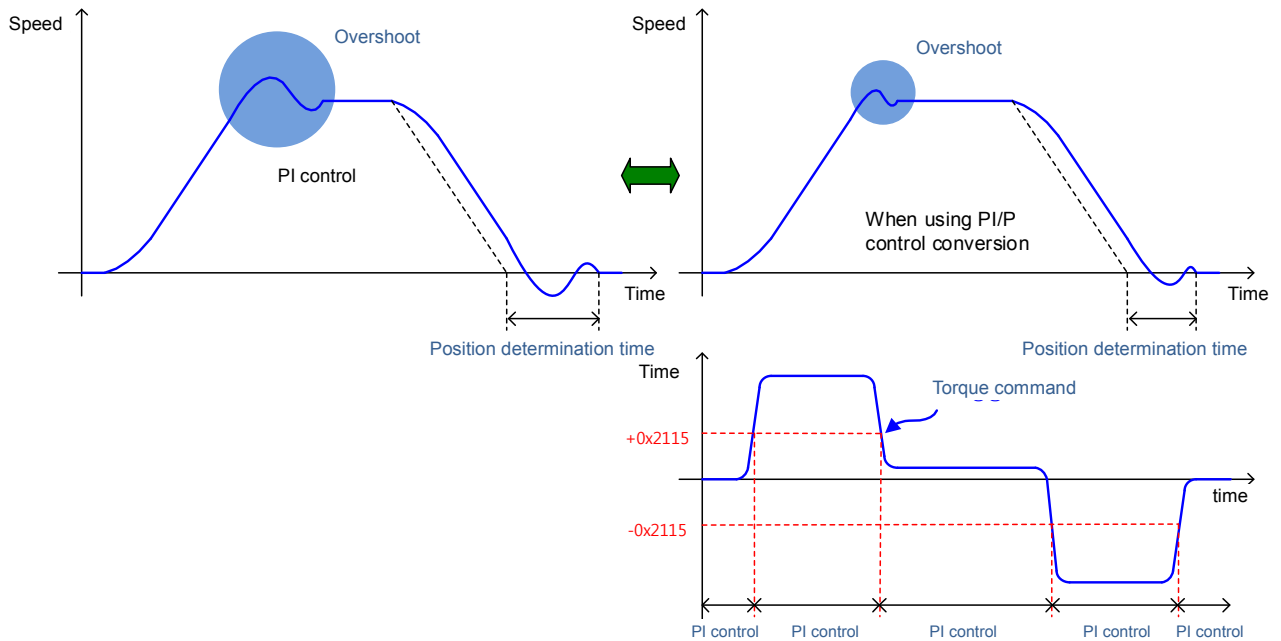

10.10 Dynamic Brake

What is Dynamic Brake?

: It refers to rapidly stopping the motor by electrically shorting the phase of the servo motor

Circuits related with dynamic brake is installed inside the drive

This drive shorts either 2 phases or 3 phases, depending on the model.

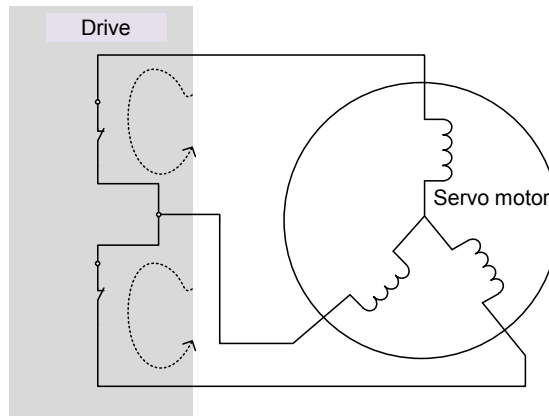

You can set various stop modes shown below by configuring the dynamic brake control mode (0x2012)

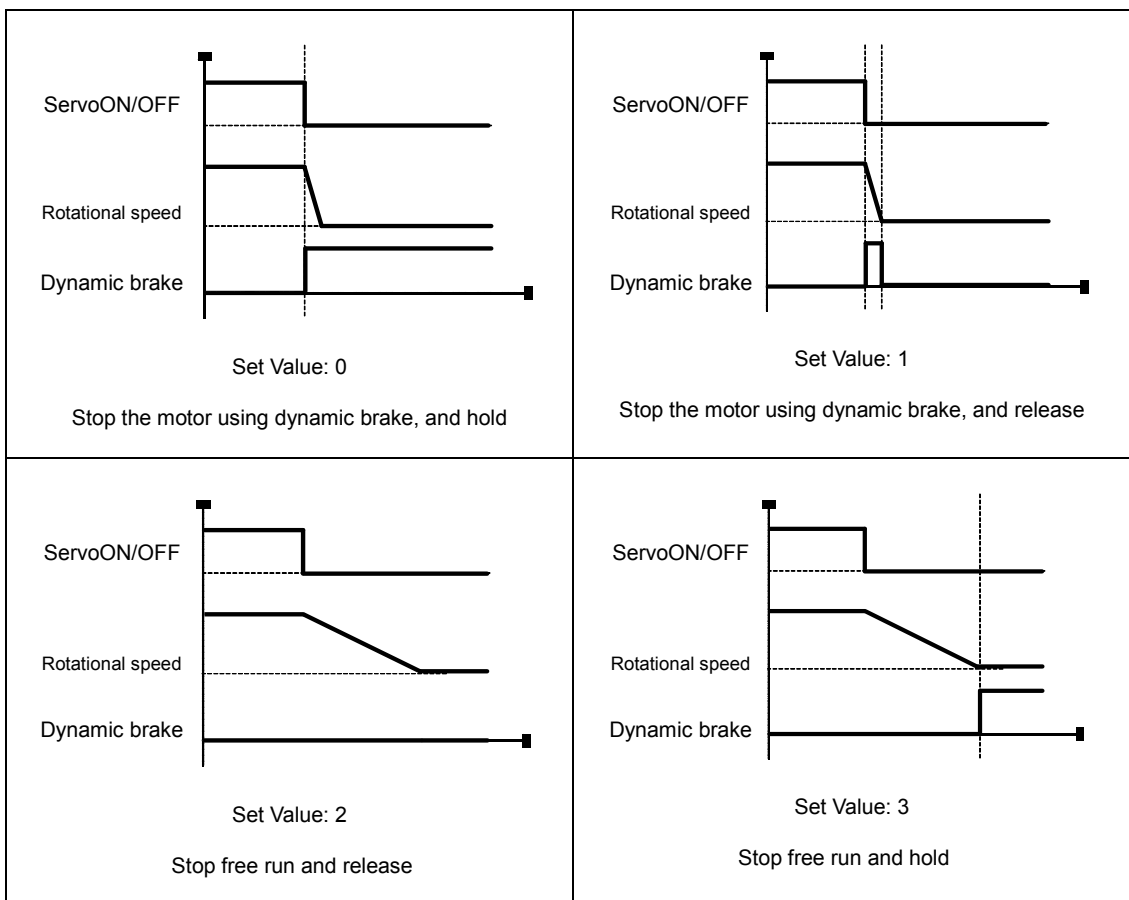

■ Related Objects

Index	Sub Index	Name	Variable Format	Accessibility	PDO Allocation	Unit
0x2012	-	Dynamic Brake Control Mode	UINT	RW	No	-
0x2013	-	Emergency Stop Configuration	UINT	RW	No	-

10.11 Regeneratiion BrakeResistorSetting

Regeneration refers to the motor's kinetic energy being converted to electrical energy due to driving a load with high inertia or abrupt deceleration, which then flows into the drive. When this happens, regeneration brake is used to inhibit the rise of the drive's internal voltage (V_{DC}) and thereby prevent damage to the drive.

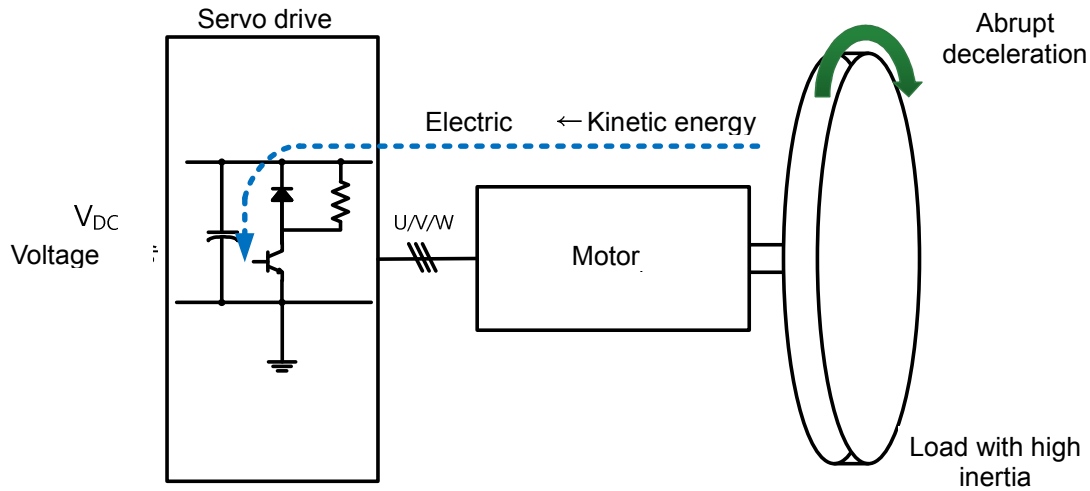

■ Related Objects

Index	Sub Index	Name	Variable Format	Accessibility	PDO Allocation	Unit
0x2009	-	Regeneration brake Resistor Configuration	UINT	RW	No	-
0x200A	-	Regeneration brake Resistor Derating Factor	UINT	RW	No	%
0x200B	-	Regeneration brake Resistor Value	UINT	RW	No	Ω
0x200C	-	Regeneration brake Resistor Power	UINT	RW	No	Watt
0x200D	-	Peak Power of Regeneration brake Resistor	UINT	RW	No	Watt
0x200E	-	Duration Time @ Peak Power of Regeneration brake Resistor	UINT	RW	No	ms

10.11.1 Using Internal Regeneration brake resistor

This drive has a built-in regeneration brake corresponding to the drive power. Specifications of internal regeneration brake for each drive power are as follows.

Drive Power	Internal Resistance	Internal Resistance Power
100W	100Ω	50W
200W	100Ω	50W
400W	100Ω	50W
1KW	40Ω	100W
3.5KW	12.6Ω	150W

To use the regeneration broke built in the drive, you should set the brake in the following order.

1. Regeneration brakewiring

- Check for B, BI terminal short (default short at the time of release from the factory, 1kW or less)

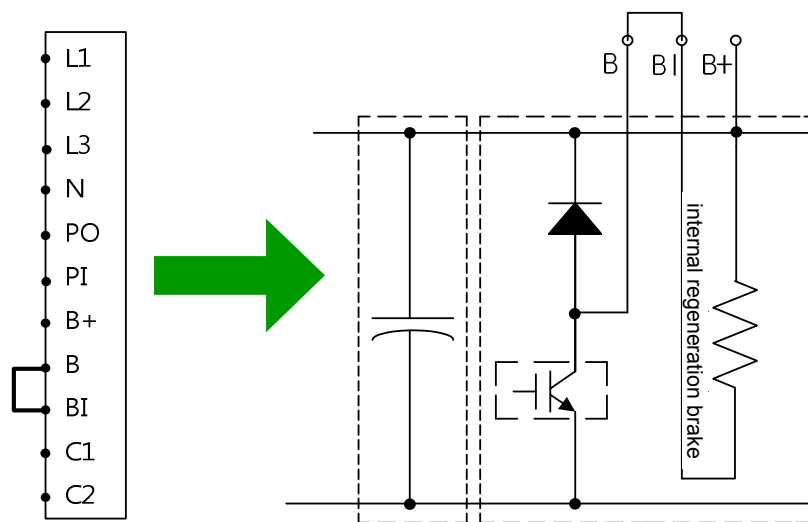

Wiring for internal regeneration brake resistor

2. Regeneration brake resistor setting (0x2009)
 - Select the built-in regeneration brake (0x2009 = 0)
 - Attach to the backside of the heat protection panel
 - Default value: 0
3. Check the internalregeneration brake value and power
 - Check internalregeneration brake value (0x200B)
 - Check regeneration brakepower (0x200C)
 - 1KW or less : Attach to the backside of the heat protection panel(See the figure below)
 - 3.5KW ~ 15KW : install inside the drive
 - 15KW or above: no internalregeneration brake

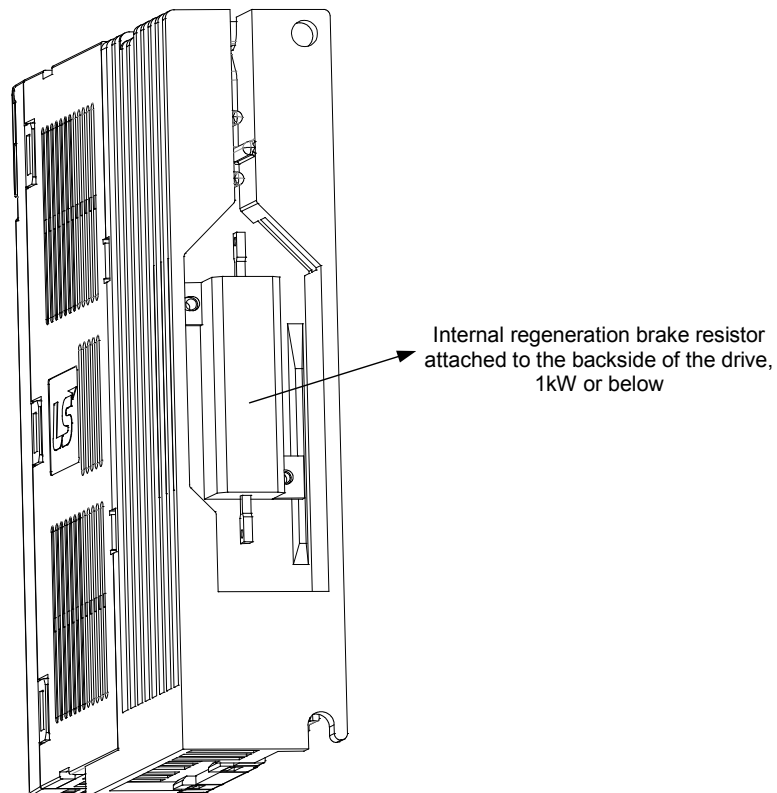

10.11.2 Using External Regeneration brake resistor

When using an external regeneration brake under consideration of the operation environment, you should set the brake in the following order.

1. External regeneration brakewiring

- Connect the external regeneration brake to the B, B+ terminal.
- Remove shorts from B, BI terminals (default short at the time of release from the factory, 1kW or less)

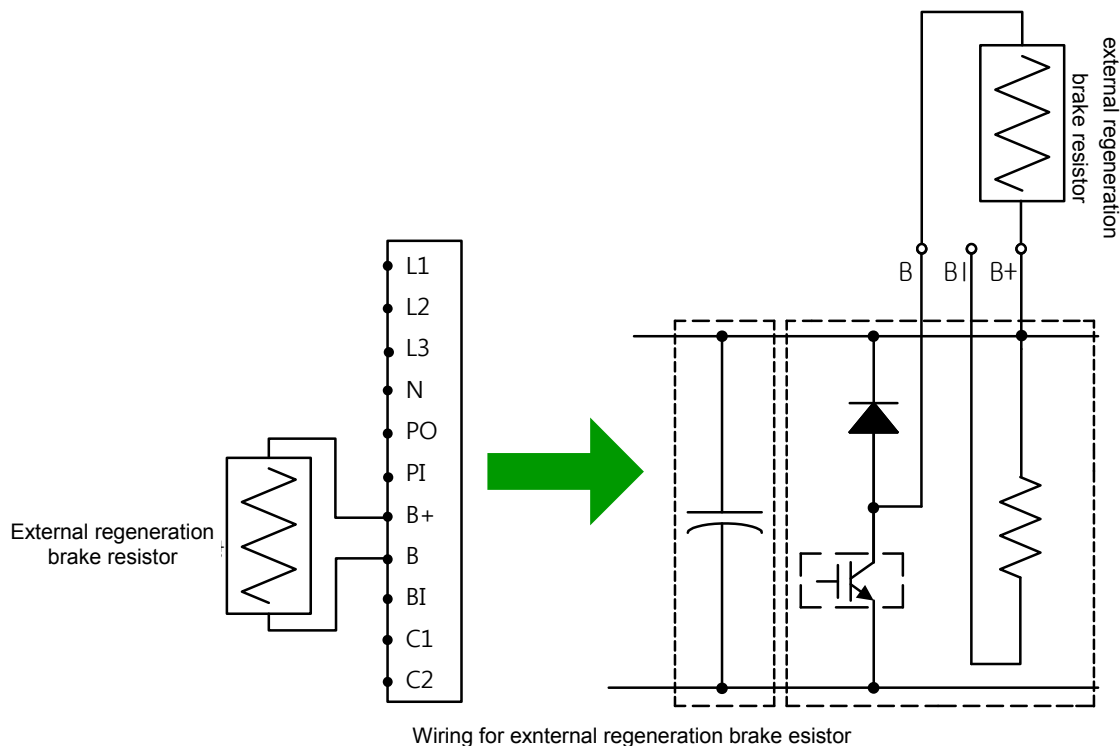

2. Regeneration brakesetting (0x2009)

- Select the external regeneration brake (0x2009=1)
- Select this when connecting a regeneration brake with power larger than the internal regeneration brake

3. Regeneration brake value setting (0x200B)

- Set the resistance value of the regeneration brakeregeneration brake to [Ω]Unit
- The value should be set if the regeneration brakesetting (0x2009) is 1.
- Default value: 0

4. Regeneration brakepower setting (0x200C)
 - Set the power of the externalregeneration braketo [W]Unit.
 - The value should be set if the regeneration brakesetting (0x2009) is 1.
 - Default value: 0
5. Regeneration brake peak power and duration setting (0x200D, 0x200E)
 - Set the power and time to the peak power and the duration time provided by the data sheet of the external regeneration brake
 - When there is no separately provided values, set the peak power to 5 times the regeneration brake power setting(0x200C), and set the duration time to 5000[ms](the exact values may vary depending on the regeneration brake specifications and brakes)
 - The value should be set if the regeneration brakesetting (0x2009) is 1.

The specifications of the optional regeneration brake provided by us for use of external regeneration brakeare as follows

Drive Power	Resistance	Brake Power	Model
100W	50Ω	140W	APCS-140R50
200W			
400W			
1KW	30Ω	300W	APCS-300R30
3.5KW	30Ω	600W	APC-600R30

10.11.3 Other Considerations

You can set the regeneration brakederating factor(0x200A) based on consideration of the installation environment and heat protection condition. If the heat protection condition is poor, use the brake after derating (below the power).

When derating (set the vale to 100 or below), the regeneration overload alarm (AL-23) sets off faster if the set value is smaller.

If you want to set the derating factor to 100% or above, you should fully consider the heat protection condtion of the installed drive.

10.12 Encoder Signal Output

The drive internally processes the signal from the encoder, and outputs them in the form of pulses. The pulses are output using the line drive method through the pins allocated by default to the I/O connector (1~6). The pulses can be output using the open collector method depending on the setting of the encoder output mode [0x3007].

Output using the open collector method uses the DO06 (PHASE A), DO07 (PHASE B), DO08(PHASE B) ports allocated by default to digital output signal, masking the corresponding output function.

You can set the number of encoder pulses output per 1 rotation with the encoder output pulse [0x3006] value.

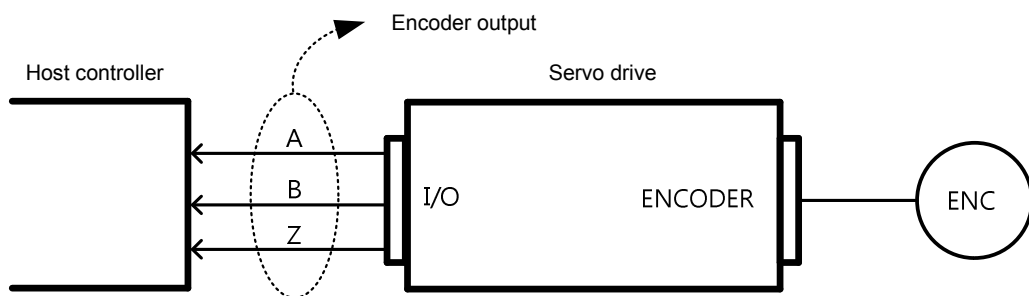

The encoder signal output frequency of the drive is up to 200 [Kpps] when using the open collector method, and up to 2.0 [Mpps] when using the line drive method.

The motor rotational speed is limited depending on the set value of number of encoder output pulses per rotation: therefore, an appropriate value should be set.

Example) when outputting 50000[ppr] using the line drive method, up to 2400[rpm] can be achieved.

$$2400[\text{rpm}] = 2 \cdot 10^6 / 50000 \cdot 60$$

Encoder Output Signal of the Line Drive Method

Pin No.	Name	Allocation	Description	Details
1	AO	-	Encoder Signal A	Outputs divided encoder signals (Phase A, B, Z) using the line drive method. The output division can be set at [0x3006].
2	/AO	-		
3	BO	-	Encoder Signal B	
4	/BO	-		
5	ZO	-	Encoder Signal Z	
6	/ZO	-		

■ Encoder Output Signal of the Open Collector Method

Pin No.	Name	Allocation	Description	Details
45	DO06+	AO	Encoder Signal A	Outputs divided encoder signals (Phase A, B, Z) using the open collector method. The output division can be set at [0x3006]. Use of open collector encoder output can be set at [0x3007].
46	DO06-	/AO		
47	DO07+	BO	Encoder Signal B	
48	DO07-	/BO		
49	DO08+	ZO	Encoder Signal Z	
50	DO08-	/ZO		

■ Related Objects

Index	Sub Index	Name	Variable Format	Accessibility	PDO Allocation	Unit
0x3006	-	Encoder Output Pulse	UDINT	RW	No	Pulse/rev.
0x3007	-	Encoder Output Mode	UINT	RW	No	-

10.13 Absolute Encoder Data Transmission (ABSRQ)

When absolute encoder data is requested, the absolute encoder data is transmitted to the host controller through the encoder output signals AO and BO, in the form of quadrature pulse.

The encoder output pulse is output at the speed of 500[Kpps].

The drive, when the ABSRQ signal is input, first transmits the multi-turn data, followed by transmission of single-turn data.

(See 7.2 Input/Output Signal Setting for allocation of ABSRQ signal)

■ Absolute Data Transmission/Reception Sequence

1. When the host controller is ready to receive the data, set the ABSRQ signal to ON.

The ABSRQ signal can be input through digital input or ABSRQ bit of drive control input 2 [0x2120]. (See 1.3 L7P Indexer Servo Drive Communication Address Table for communication address of Modbus RTU)

2. When the drive receives the ABSRQ signal, it prepares for encoder data transmission after about 100[ms] delay.
3. The drive transmits the multi-turn data for up to 200[ms]. During the 200[ms] after the multi-turn data transmission begins, the drive prepares for transmission of single-turn data.
4. The drive transmits the single-turn data for up to 1200[ms]. The output data at this time has the value determined under consideration of the number of encoder output pulses (division ratio). 200[ms] after the single-turn data transmission begins, the drive goes back to the normal encoder output signal.

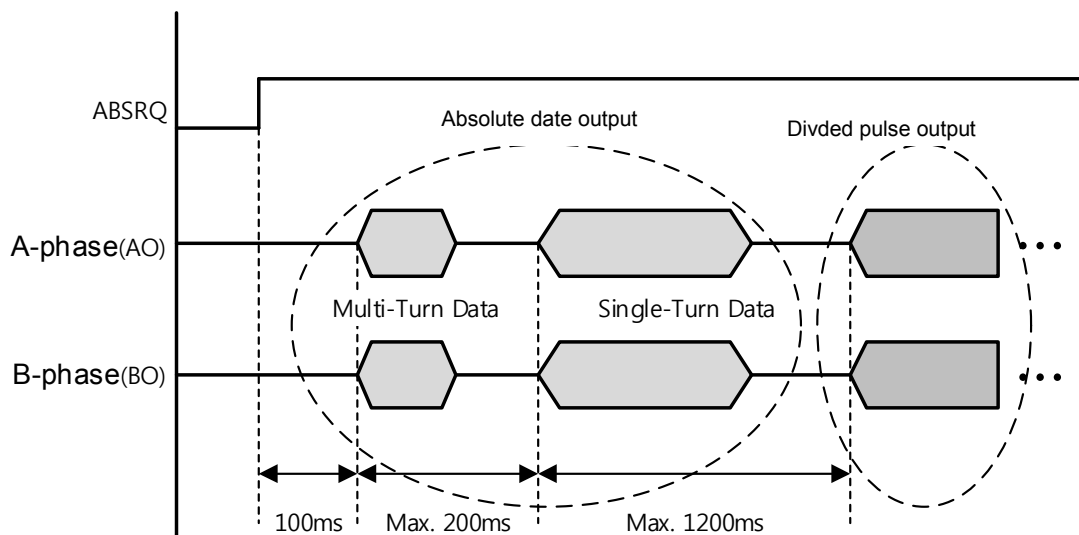

11. Tuning

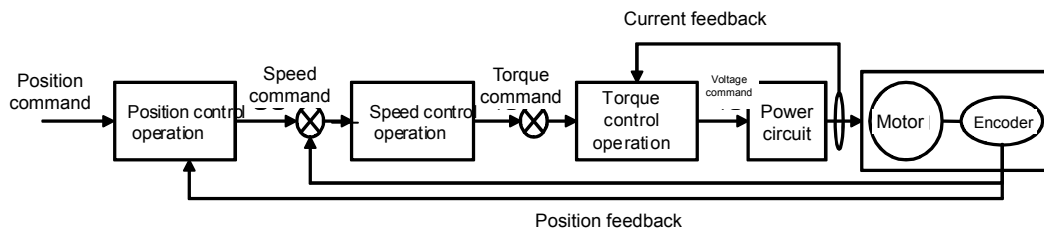

You can use the drive at the torque control mode, speed control mode or position control mode, depending on the connection method with the host device. The drive's control structure takes the cascade form, where the position control is positioned at the outermost and the current control is positioned at the innermost. Depending on the drive's operation mode, you can tune the gain-related parameters of the torque controller, speed controller or position controller to suit your purposes.

11.1 Automatic Gain Tuning

You can automatically set gains corresponding to the load conditions, using commands generated by the drive itself. The gain-related parameters subject to change are as follows.

- Inertia, inertia ratio, positionloopgain, speedloopgain, speedintegraltime constant, torquecommandfiltertime constant, notchfilter3frequency, notchfilter4frequency

The overall gain is set to either high or low, depending on the set value of the system rigidity for gaintuning. Please set the appropriate value depending on the rigidity of the load being operated.

As shown in the figure below, commands in the sinusoidal form are generated either in the forward or reverse direction depending on the set value of the offline gain tuning direction. You can set the distance covered during tuning with the offline gain tuning distance (0x2511). The distance increases along with the set value: please set the appropriate distance depending on the situation. Please secure a sufficient distance before gain tuning (1 rotation or above).

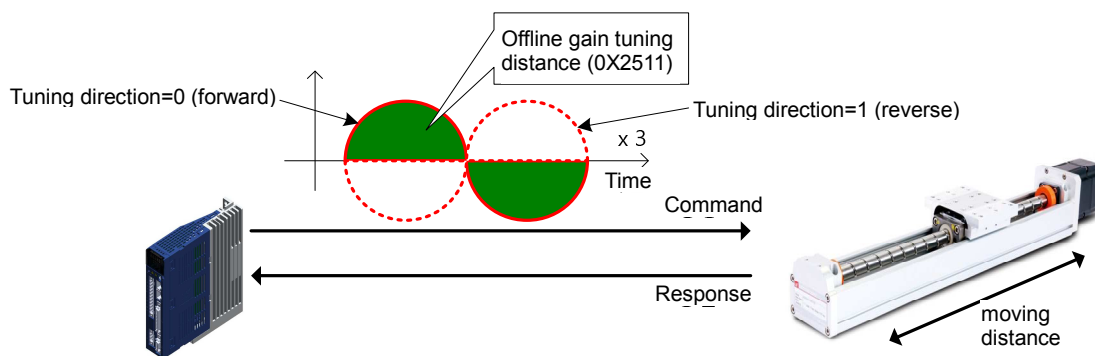

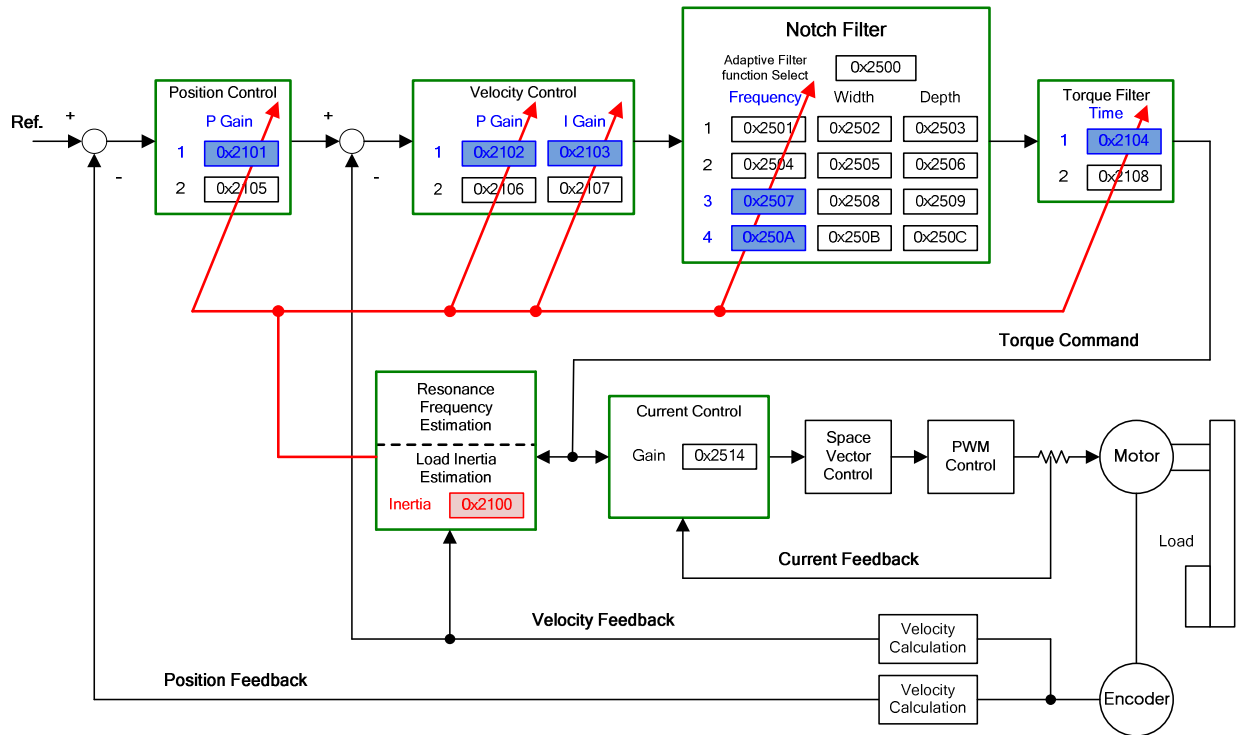

■ Related Objects

Index	Sub Index	Name	Variable Format	Accessibility	PDO Allocation	Unit
0x250E		System Rigidity for Gain Tuning	UINT	RW	No	-
0x2510	-	Off-line Gain Tuning Direction	UINT	RW	No	-
0x2511		Off-line Gain Tuning Distance	UINT	RW	No	-

11.2 ManualGainTuning

11.2.1 Order Gain Tuning

When using a cascade-type controller, first tune the gain of the speed controller positioned inside, and then tune the gain of the position controller positioned outside.

That is, the order tuning is gain→integralgain→ Feedforwardgain.

The role of each gain is as follows.

- Proportion gain: determines controller BW
- Integralgain: determines error of the steady state, causes overshoot
- Feedforwardgain: improves the system's lag characteristic
- Differential gain: damping for the system (not provided)

■ SpeedController Tuning

(1) Inertial ratio setting

- Use automatic inertia estimation function, or manual tuning

(2) Proportion gainsetting

- Torque/noise monitoring before vibration occurs

(3) Integralgainsetting

- Speed overshoot and steady-state error monitoring
- If you want to increase integralgain but overshoot occurs, you can use the P/PI conversion mode
- The integral gain of this drive is integraltime constant,

(4) Speedcommandfilterandspeedfeedbackfiltersetting

■ PositionController Tuning

(1) Porportion gainsetting

- Torque, position error, noise monitoring before vibration occurs

(2) Feedforward setting

- Positionerror monitoring
- Feedforward filtercan be set
- If you want to increase feed forward but overshoot occurs, set filter
- Feedforward value can be set from 0 to 100%. The value is the ratio of the position command value currently being input against the difference

- (3) Positioncommandfilter setting
 - It provides smoother positioncommand

11.3 Vibration Control

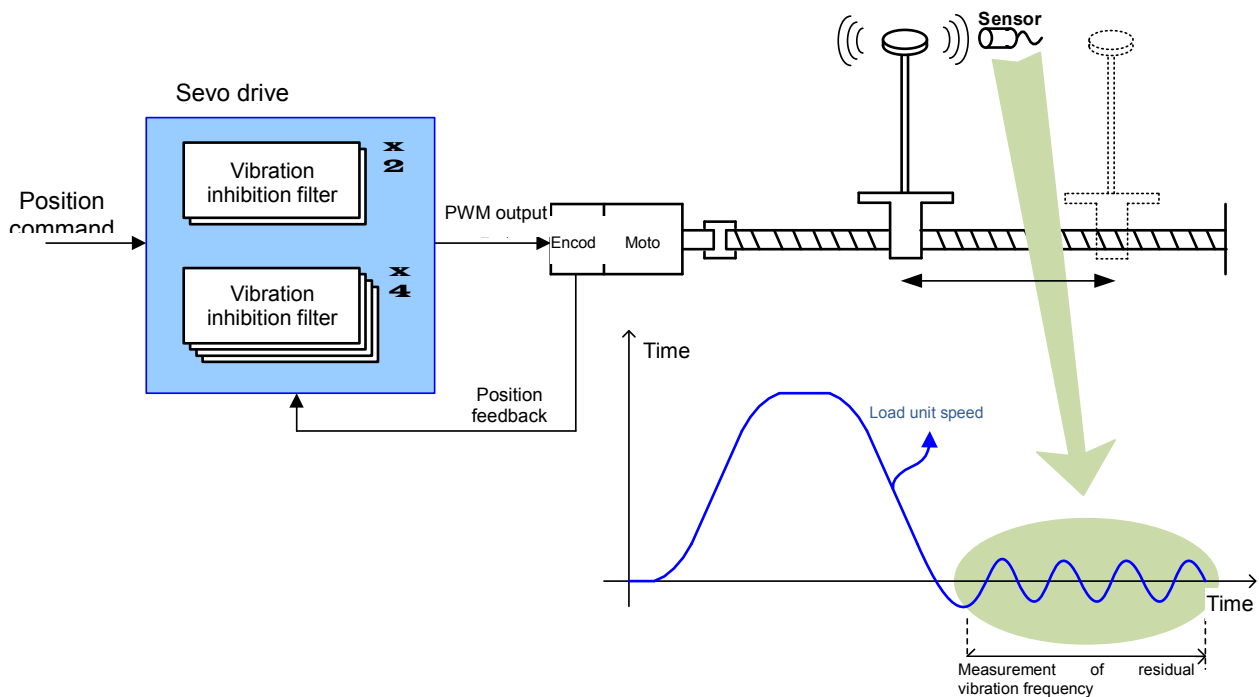

The vibration control function has the following features.

- Provides 4-layer notch filter
 - Frequency, width, depth setting
 - Aytomatic setting through real-time FFT
 - $50[\text{Hz}] \leq \text{setting range} \leq 5000[\text{Hz}]$
- Provides 2-layer vibration inhibition filter, for vibration inhibition of the load
 - Measures the vibration frequency of the load
 - $1.0[\text{Hz}] \leq \text{setting range} \leq 100.0[\text{Hz}]$

11.3.1 NotchFilter

Notchfilter is a type of Band Stop filter which removes certain frequency components. By removing resonance frequency component of the mechanic unit using the notch filter, you can remove vibration while setting high gains.

This drive provides a total of 4 layers of noth filters, and the frequency, widt, depth can be set separately for each filter. One or two notch filters can be used as adaptive filters with automatic frequency and widt setting, through real-time frequency analysis (FTT).

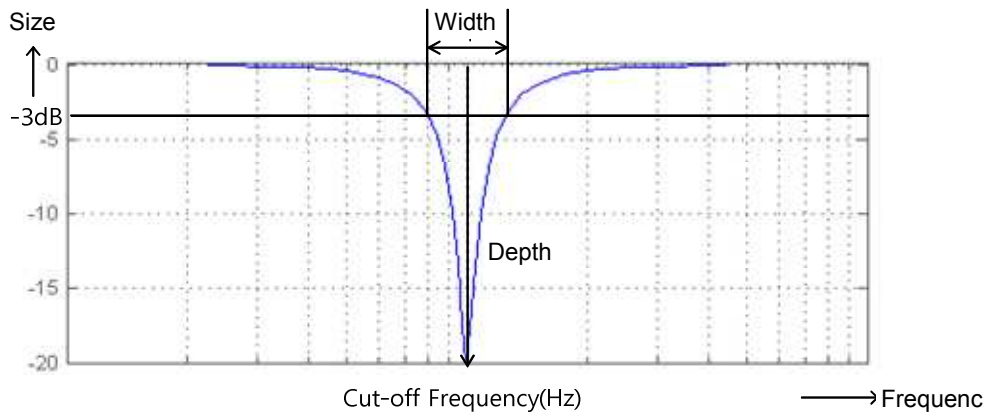

■ Related Objects

Index	Sub Index	Name	Variable Format	Accessibility	PDO Allocation	Unit
0x2501	-	Notch Filter 1 Frequency	UINT	RW	No	Hz
0x2502	-	Notch Filter 1 Width	UINT	RW	No	Hz
0x2503	-	Notch Filter 1 Depth	UINT	RW	No	-
0x2504	-	Notch Filter 2 Frequency	UINT	RW	No	Hz
0x2505	-	Notch Filter 2 Width	UINT	RW	No	Hz
0x2506	-	Notch Filter 2 Depth	UINT	RW	No	-
0x2507	-	Notch Filter 3 Frequency	UINT	RW	No	Hz
0x2508	-	Notch Filter 3 Width	UINT	RW	No	Hz
0x2509	-	Notch Filter 3 Depth	UINT	RW	No	-
0x250A	-	Notch Filter 4 Frequency	UINT	RW	No	Hz
0x250B	-	Notch Filter 4 Width	UINT	RW	No	Hz
0x250C	-	Notch Filter 4 Depth	UINT	RW	No	-

11.3.2 Adaptive Filter

Adaptive filter reduces vibration by automatically setting the notch filters by performing real-time analysis on vibration frequency generated from the load during drive operation through speed feedback signals.

One or two notch filters can be automatically set by detecting the vibration frequency through frequency analysis. The frequency and width are automatically set, and the set value is used for depth.

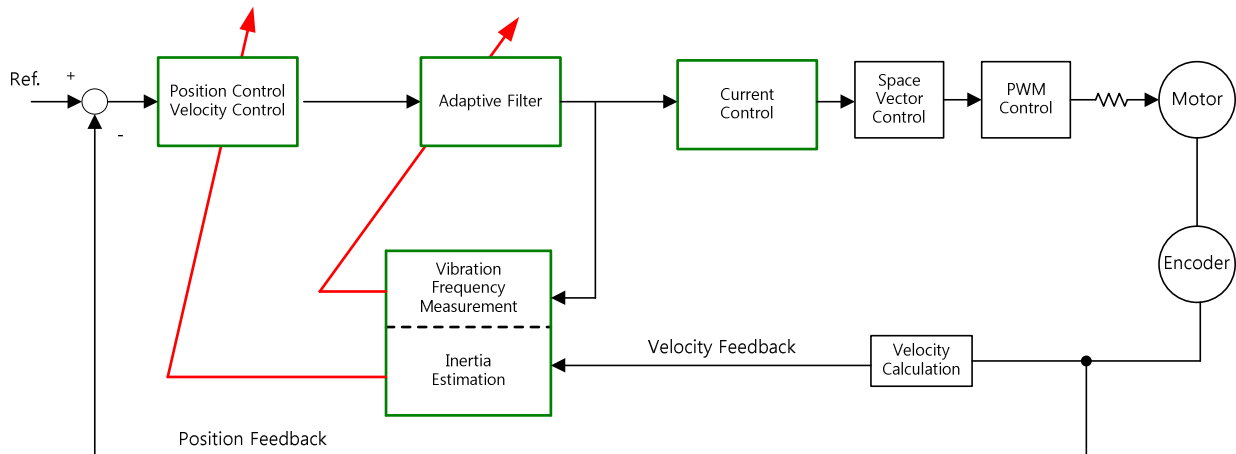

■ Related Objects

Index	Sub Index	Name	Variable Format	Accessibility	PDO Allocation	Unit
0x2500	-	Adaptive Filter Function Select	UINT	RW	No	-

- Adaptive filter function setting(0x2500)

Set Value	Details
0	No adaptive filter
1	Uses only 1 adaptive filter. The automatically set values can be confirmed at notchfilter 4 setting (0x250A, 0x250B).
2	Uses only 2 adaptive filters. The automatically set values can be confirmed at notch filter3 (0x2507, 0x2508) and notch filter 4 (0x250A, 0x250B) setting.
3~5	Reserved

11.4 AnalogMonitor

The drive provides 2-channel analog monitor output, for drive gain tuning or internal status parameter monitoring.

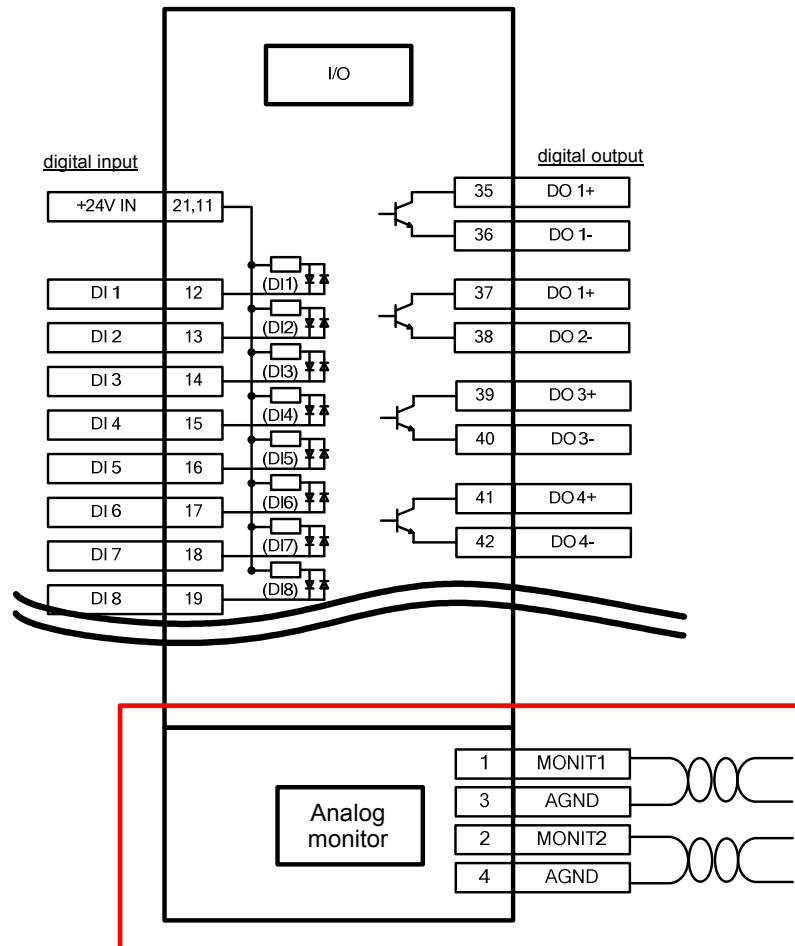

■ Related Objects

Index	Sub Index	Name	Variable Format	Accessibility	PDO Allocation	Unit
0x2220	-	Analog Monitor Output Mode	UINT	RW	No	-
0x2221	-	Analog Monitor Channel 1 Select	UINT	RW	No	-
0x2222	-	Analog Monitor Channel 2 Select	UINT	RW	No	-
0x2223	-	Analog Monitor Channel 1 Offset	DINT	RW	No	-
0x2224	-	Analog Monitor Channel 2 Offset	DINT	RW	No	-
0x2225	-	Analog Monitor Channel 1 Scale	UDINT	RW	No	-
0x2226	-	Analog Monitor Channel 2 Scale	UDINT	RW	No	-

- Analogmonitor outputmode(0x2220) setting

The output range of analogmonitor is -10~+10V. With set value of 1, only the absolute value (positive value) of the output value is displayed.

Set	Description	Illustration
0	Output in negative/positive values	<p>The graph shows a straight line passing through the origin (0V) on a coordinate system. The vertical axis is labeled 'Analog output voltage'. Dashed lines indicate points at +4V and -4V on the vertical axis.</p>
1	Output only in positive value	<p>The graph shows a V-shaped line with its vertex at the origin (0V) on a coordinate system. The vertical axis is labeled 'Analog output voltage'. Dashed lines indicate points at +4V on the vertical axis.</p>

- Analogmonitor channel 1 setting (0x2221)

You can set the monitoring variables to output through the monitor output channel 1.

Set Value	Displayed Items	Unit
0	speedfeedback	rpm
1	speedcommand	rpm
2	speederror	rpm
3	torquefeedback	%
4	torquecommand	%
5	positionerror	pulse
6	accumulated operation overload rate	%
7	DC Link voltage	V
8	accumulated 11-54egeneration overload rate	%
9	encoder single-turn data	pulse
10	Inertia ratio	%
11	Full-Closed positionerror (Reserved)	UU
12	drive temperature 1	°C
13	drive temperature2	°C
14	encoder temperature (Reserved)	°C
15	Hall sensor signal	
16	phase U current	A
17	phase V current	A
18	phase W current	A
19	position actual value	UU
20	position demand value	UU
21	positioncommandspeed	rpm

The voltage for analogmonitor output is calculated using the following formulas.

Channel 1 output voltage[V] = [monitoring signal value(0x2221) –offset(0x2203)] / scale (0x2205)

Channel 2 output voltage[V] = [monitoring signal value(0x2222) –offset(0x2204)] / scale (0x2206)

■ Setting Example

The figure below shows an example of monitoring when driving with speedfeedback signal of 1000rpm.

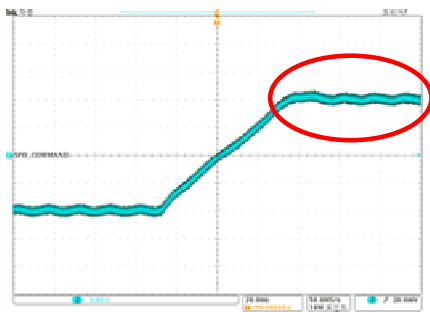

Output offset : 0 rpm
Output scale : 500rpm/V

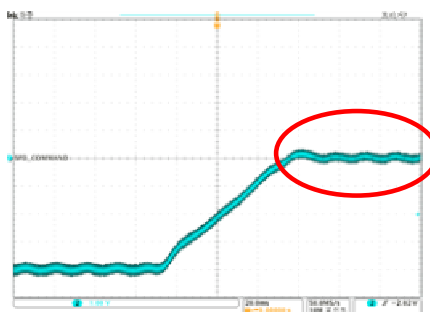

Output offset : 1000 rpm
Output scale : 500rpm/V



Output offset : 1000 rpm
Output scale : 100rpm/V



12. Procedure Functions

These functions are auxiliary functions provided by the drive. The list of the functions is provided below. These functions can be performed with procedure command code (0x2700) and procedure command factor (0x2701). The procedure functions can be activated using the servo setting tool.

Procedure Command	Code	Description
Manual JOG	0x0001	Manual JOG operation
Program JOG	0x0002	Program JOG operation
Alarm History Reset	0x0003	Remove alarm history
Off-Line Auto-Tuning	0x0004	Off-Line Auto-Tuning
Index Pulse Search	0x0005	Index (Z) Pulse Search
Absolute Encoder Reset	0x0006	Reset absolute encoder
Max. Load Torque Clear	0x0007	Reset maximum operation overload (0x2604)
Calibrate Phase Current Offset	0x0008	Calibrate phase current offset
Software Reset	0x0009	Software reset
Commutation	0x000A	Commutation

12.1 Manual Jog Operation

Jog operation is a function to check the action of the servo motor by speed control, without the host device.

Please check the following before activation.

- The main power is ON
- No alarm
- Servo is OFF
- Operation speed is set considering the condition of the machine

■ Related Objects

Index	Sub Index	Name	Variable Format	Accessibility	PDO Allocation	Unit
0x2300	-	Jog Operation Speed	INT	RW	No	rpm
0x2301	-	Speed Command Acceleration Time	UINT	RW	No	ms
0x2302	-	Speed Command Deceleration Time	UINT	RW	No	ms
0x2303	-	Speed Command S-curve Time	UINT	RW	No	ms

12.2 Program Jog Operation

Jogoperation is a function to check the action of the servo motor by speed control, without the host device, based on the preset operation speed and operation time.

Please check the following before operation

- The main power is ON
- No alarm
- Servo is OFF
- Speed and time are set considering the condition of the machine

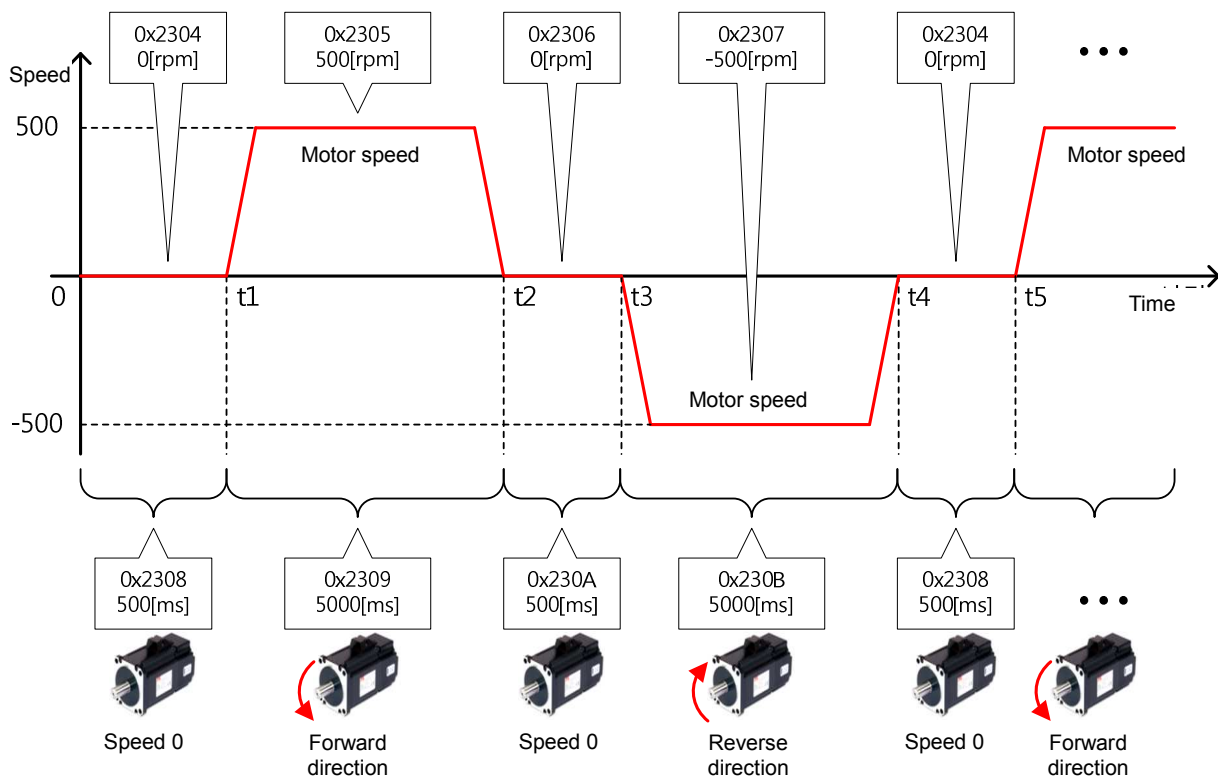

■ Related Objects

Index	Sub Index	Name	Variable Format	Accessibility	PDO Allocation	Unit
0x2304	-	Program Jog Operation Speed 1	INT	RW	No	rpm
0x2305	-	Program Jog Operation Speed 2	INT	RW	No	rpm
0x2306	-	Program Jog Operation Speed 3	INT	RW	No	rpm
0x2307	-	Program Jog Operation Speed 4	INT	RW	No	rpm
0x2308	-	Program Jog Operation Time 1	UINT	RW	No	ms
0x2309	-	Program Jog Operation Time 2	UINT	RW	No	ms
0x230A	-	Program Jog Operation Time 3	UINT	RW	No	ms
0x230B	-	Program Jog Operation Time 4	UINT	RW	No	ms

12.3 Alarm Record Deleting

This function deletes all alarm code history Stored in the drive. The alarm history of the newest alarm and upto 16 previous alarms is Stored in the drive.

The alarm history can be viewed at0x2702:01~16, as shown below. The newest recent alarm is displayed at 0x2702:01.

2702:0	Servo Alarm History	RO	> 16 <
2702:01	Alarm code 1(Newest)	RO	[51]POS following
2702:02	Alarm code 2	RO	[51]POS following
2702:03	Alarm code 3	RO	[51]POS following
2702:04	Alarm code 4	RO	[51]POS following
2702:05	Alarm code 5	RO	[51]POS following
2702:06	Alarm code 6	RO	[51]POS following
2702:07	Alarm code 7	RO	[51]POS following
2702:08	Alarm code 8	RO	[51]POS following
2702:09	Alarm code 9	RO	[51]POS following
2702:0A	Alarm code 10	RO	[51]POS following
2702:0B	Alarm code 11	RO	[51]POS following
2702:0C	Alarm code 12	RO	[51]POS following
2702:0D	Alarm code 13	RO	[51]POS following
2702:0E	Alarm code 14	RO	[51]POS following
2702:0F	Alarm code 15	RO	[51]POS following
2702:10	Alarm code 16(Oldest)	RO	[51]POS following

■ Related Objects

Index	Sub Index	Name	Variable Format	Accessibility	PDO Allocation	Unit
0x2702	-	Servo Alarm History	-	-	-	-
	1	Alarm code 1(Newest)	STRING	RO	No	-
	2	Alarm code 2	STRING	RO	No	-
	3	Alarm code 3	STRING	RO	No	-
	4	Alarm code 4	STRING	RO	No	-
	5	Alarm code 5	STRING	RO	No	-
	6	Alarm code 6	STRING	RO	No	-
	7	Alarm code 7	STRING	RO	No	-
	8	Alarm code 8	STRING	RO	No	-
	9	Alarm code 9	STRING	RO	No	-
	10	Alarm code 10	STRING	RO	No	-
	11	Alarm code 11	STRING	RO	No	-
	12	Alarm code 12	STRING	RO	No	-
	13	Alarm code 13	STRING	RO	No	-
	14	Alarm code 14	STRING	RO	No	-
	15	Alarm code 15	STRING	RO	No	-
16	Alarm code 16 (oldest)	STRING	RO	No	-	

12.4 AutomaticGainTuning

See 8.1 Automatic Gain Tuning for further details.

12.5 IndexPulse Search

The Index pulse search function searches for the encoder's Index(Z) pulse position and stops the machine there. As it uses the speed operation mode to find the position, it is used in finding an estimation of the position. The exact index pulse position can be found with homing operation.

The speed for index pulse search is set at 0x230C[rpm].

- The main power is ON
- No alarm
- Servo is OFF
- Safety Torque Off(STO) Connector is equipped
- Operation speed is set considering the condition of the machine
-

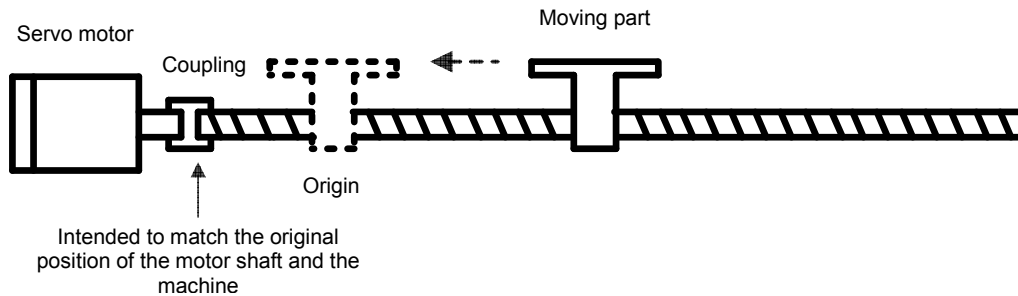

■ Related Objects

Index	Sub Index	Name	Variable Format	Accessibility	PDO Allocation	Unit
0x230C	-	Index Pulse Search Speed	INT	RW	No	rpm

12.6 Absolute Encoder Setting

Resets absolute encoder. Absolute encoder reset is needed in the following cases.

- Setting up the mechanical unit for the first time
- Encoder low voltage occurs
- The multi-turn data of absolute encoder needs to be 0

Resetting the absolute encoder resets multi-turn data(0x260A) and single-turn data(0x2607) back to 0. Re supplying power after reset changes the position actual value (0x6064) to the reset position value.

After power resupply, the position actual value (0x6064) of the absolute encoder is read and displayed by applying Home offset(0x607C).

Changing the home offset (0x607C) during operation will not change the position actual value (0x6064).

■ Related Objects

Index	Sub Index	Name	Variable Format	Accessibility	PDO Allocation	Unit
0x2005	-	Absolute Encoder Configuration	UINT	RW	No	-
0x2607		SingleTurn Data	UDINT	RO	Yes	pulse
0x260A		MultiTurn Data	DINT	RO	Yes	rev

12.7 Instantaneous Maximum Torque Reset

Resets the instantaneous maximum overload rate (0x2604) into 0. The instantaneous maximum overload rate represents the maximum operation overload rate output by the drive instantaneously.

The peak load from the moment the servo is powered on to the present is displayed in percentage to the rated output. The unit is [0.1%]. Resupplying power resets the value to 0.

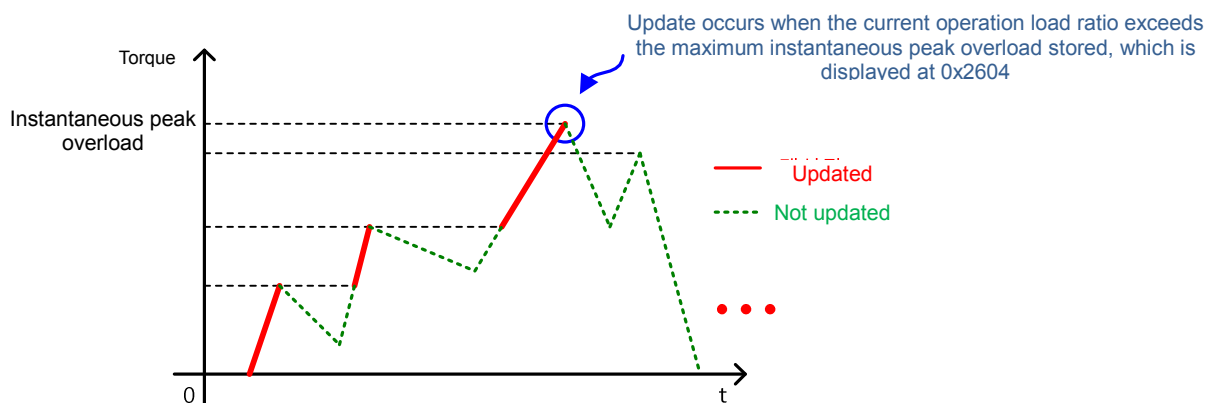

■ **Related Objects**

Index	Sub Index	Name	Variable Format	Accessibility	PDO Allocation	Unit
0x2604	-	Instantaneous Maximum Operation Overload	INT	RO	Yes	0.1%

12.8 Phase Current Offset Tuning

This function automatically tunes the current offset of Phase U/V/W. Phase current offset can be adjusted in accordance with the user environment. The product is released with the offset tuned by default.

The measured Phase U/V/W offset are stored at 0x2015, 0x2016, 0x2017, respectively. AL-15 occurs when the offset is abnormally large.

■ **Related Objects**

Index	Sub Index	Name	Variable Format	Accessibility	PDO Allocation	Unit
0x2015	-	U Phase Current Offset	INT	RW	No	0.1%
0x2016	-	V Phase Current Offset	INT	RW	No	0.1%
0x2017	-	W Phase Current Offset	INT	RW	No	0.1%

12.9 Software Reset

This function resets the servo drive with the software. Software reset means restarting the drive's program, achieving an effect similar to resupplying the power.

This function can be used in the following cases.

- Parameters which requires power resully are changed
- Drive need to be restarted when unresettable alarmis set off.

12.10 Commutation

Commutation functions for acquiring initial angle information of the motor. When using a motor without the hall sensor, the initial angle information needs to be acquired before operation.

■ Related Objects

Index	Sub Index	Name	Variable Format	Accessibility	PDO Allocation	Unit
0x2019	-	Linear Scale Resolution	UINT	RW	No	nm
0x201A	-	Commutation Method	UINT	RW	No	-
0x201B	-	Commutation Current	UINT	RW	No	0.1%
0x201C	-	Commutation Time	UINT	RW	No	ms

0x1001 Error Register							
Variable Format	Setting Range	Default Value	Unit	Accessibility	PDOAllocation	Change Property	Store
USINT	-	0x00	-	RO	No	-	No

Shows the device's error register values. The value is Stored to a part of the emergency message.

bit	Setting Details
0	0 : no error
	1 : error found
1 to 7	Reserved

0x1008 Device Name							
Variable Format	Setting Range	Default Value	Unit	Accessibility	PDOAllocation	Change Property	Store
STRING	-	-	-	RO	No	-	No

Shows the device name

0x1009 Hardware Version							
Variable Format	Setting Range	Default Value	Unit	Accessibility	PDOAllocation	Change Property	Store
STRING	-	-	-	RO	No	-	No

Shows the device hardware version

0x100A Software Version							
Variable Format	Setting Range	Default Value	Unit	Accessibility	PDOAllocation	Change Property	Store
STRING	-	-	-	RO	No	-	No

Shows the device software version

0x1010 Store Parameters							
SubIndex 0		Number of entries					
Variable	Setting Range	Default Value	Unit	Accessibility	PDOAllocation	Change	Store

Format				ity	on	Property	
USINT	-	5	-	RO	No	-	No
SubIndex 1		Store all parameters					
Variable Format	Setting Range	Default Value	Unit	Accessibil ity	PDOAllocati on	Change Property	Store
UDINT	0 to 0xFFFFFFFF	0	-	RW	No	-	No
SubIndex 2		Store communication parameters					
Variable Format	Setting Range	Default Value	Unit	Accessibil ity	PDOAllocati on	Change Property	Store
UDINT	0 to 0xFFFFFFFF	0	-	RW	No	-	No
SubIndex 3		Store CiA402 parameters					
Variable Format	Setting Range	Default Value	Unit	Accessibil ity	PDOAllocati on	Change Property	Store
UDINT	0 to 0xFFFFFFFF	0	-	RW	No	-	No
SubIndex 4		Store drive specific parameters					
Variable Format	Setting Range	Default Value	Unit	Accessibil ity	PDOAllocati on	Change Property	Store
UDINT	0 to 0xFFFFFFFF	0	-	RW	No	-	No
SubIndex 5		Store index parameters					
Variable Format	Setting Range	Default Value	Unit	Accessibil ity	PDOAllocati on	Change Property	Store
UDINT	0 to 0xFFFFFFFF	0	-	RW	No	-	No

Stores the drive parameters in the memory. To prevent miskaes, using the ASCII code corresponding to 'Store' at the relevant subindex will store the parameters.

	MSB	16	15	LSB
	e	v	a	s
ASCII Code	0x65	0x76	0x61	0x73

Writing "Store" at SubIndex 1 will store all parameters.

Writing "Store" at SubIndex 2 will store only communication parameter (0x1000~)

Writing "Store" at SubIndex 3 will store only parameter (0x6000~).

Writing "Store" at SubIndex 4 will store only the drive's specifi cparameter (0x2000~)

Writing "Store" at SubIndex 5 will store only Index parameter (0x3000~).

0x1011		Restore Default Parameters					
SubIndex 0		Number of entries					
Variable Format	Setting Range	Default Value	Unit	Accessibility	PDOAllocation	Change Property	Store
USINT	-	5	-	RO	No	-	No
SubIndex 1		Restore all parameters					
Variable Format	Setting Range	Default Value	Unit	Accessibility	PDOAllocation	Change Property	Store
UDINT	0 to 0xFFFFFFFF	0	-	RW	No	-	No
SubIndex 2		Restore communication parameters					
Variable Format	Setting Range	Default Value	Unit	Accessibility	PDOAllocation	Change Property	Store
UDINT	0 to 0xFFFFFFFF	0	-	RW	No	-	No
SubIndex 3		Restore CiA402 parameters					
Variable Format	Setting Range	Default Value	Unit	Accessibility	PDOAllocation	Change Property	Store
UDINT	0 to 0xFFFFFFFF	0	-	RW	No	-	No
SubIndex 4		Restore drive specific parameters					
Variable Format	Setting Range	Default Value	Unit	Accessibility	PDOAllocation	Change Property	Store
UDINT	0 to 0xFFFFFFFF	0	-	RW	No	-	No
SubIndex 5		Restore index parameters					
Variable Format	Setting Range	Default Value	Unit	Accessibility	PDOAllocation	Change Property	Store
UDINT	0 to 0xFFFFFFFF	0	-	RW	No	-	No

Resets the drive’s parameters. To prevent misuses, using the ASCII code corresponding to ‘load’ will reset the parameters.

	MSB	16	15	LSB
	d	a	o	l
ASCII []	0x64	0x61	0x6F	0x6C

Writing “load” at SubIndex 1 will reset all parameters.

Writing “load” at SubIndex 2 will reset only communication parameters (0x1000~)

Writing “load” at SubIndex 3 will reset only parameters (0x6000~).

Writing “load” at SubIndex 4 will reset only the drive’s specific parameters (0x2000~)

Writing “load” at SubIndex 5 will reset only Index parameters (0x3000~).

The drive needs to be restarted for the reset value to apply.

0x1018		Identity Object					
SubIndex 0		Number of entries					
Variable Format	Setting Range	Default Value	Unit	Accessibility	PDOAllocation	Change Property	Store
USINT	-	4	-	RO	No	-	No
SubIndex 1		Vendor ID					
Variable Format	Setting Range	Default Value	Unit	Accessibility	PDOAllocation	Change Property	Store
UDINT	-	0x00007595	-	RO	No	-	No
SubIndex 2		Product code					
Variable Format	Setting Range	Default Value	Unit	Accessibility	PDOAllocation	Change Property	Store
UDINT	-	0x00010001	-	RO	No	-	No
SubIndex 3		Revision number					
Variable Format	Setting Range	Default Value	Unit	Accessibility	PDOAllocation	Change Property	Store
UDINT	-	-	-	RO	No	-	No
SubIndex 4		Serial number					
Variable Format	Setting Range	Default Value	Unit	Accessibility	PDOAllocation	Change Property	Store
UDINT	-	-	-	RO	No	-	No

Shows information on the device

13.3 Manufacturer Specific Objects

● Basic Setting(0x2000~)

0x2000	Motor ID						ALL
Variable Format	Setting Range	Default Value	Unit	Accessi bility	PDOAllo cation	Change Property	Store
UINT	1 to 9999	13	-	RW	No	Power resupply	Yes

Sets the motor's ID. For serial encoders supplied by us, the ID's are automatically set. Such ID's can be seen on the motor name plate.

Example) The name plate below tells us that the motor's ID is 137.

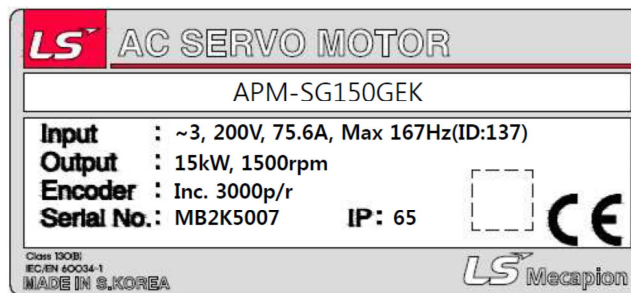

0x2001	Encoder Type						ALL
Variable Format	Setting Range	Default Value	Unit	Accessi bility	PDOAllo cation	Change Property	Store
UINT	0 to 99	1	-	RW	No	Power resupply	Yes

Sets the encoder type. Please set the appropriate encoder type, by referring to the table below. However, serial encoders supplied by us (3 in the table below) are automatically recognized regardless of the set value. In such cases, you can check the format of the automatically recognized encoder.

Set Value	Encoder Type
0	Quadrature(incremental, A lead B)
1	Quadrature(incremental, B lead A)
2	BiSSSerial (single turn only)
3	BiSS Serial Absolute(multi-turn 12bit)
4	BiSS Serial Absolute(multi-turn 16bit) coming soon
5	BiSS Serial Absolute(multi-turn 20bit) coming soon
6	BiSS Serial Absolute(multi-turn 24bit) coming soon
7	Sinusoidal(1Vpp)
8	Analog Hall
9	Sinusoidal to Biss coming soon
10	Reserved

11	Tamagawa Serial(single turn only)
12	Tamagawa Serial Absolute(multi-turn 16 bit)
13	EnDat 2.2

0x2002	Encoder Pulse per Revolution						ALL
Variable Format	Setting Range	Default Value	Unit	Accessi bility	PDOAllo cation	Change Property	Store
UDINT	0 to 1073741824	4096	pulse	RW	No	Power Resupply	Yes

Sets encoder resolution by pulse (count).Encoder resolution can generally be confirmed from the name plate (See explanation on 0x2000). However, serial encoders supplied by us are automatically recognized regardless of the set value. In such cases, you can check the resolution of the automatically recognized encoder.

0x2003	Node ID						ALL
Variable Format	Setting Range	Default Value	Unit	Accessi bility	PDOAllo cation	Change Property	Store
UINT	0 to 65535	-	-	RO	No	-	No

Shows the node ID set by the node switch of the drive. The node switch value is read only once when the power comes on. Subsequent changes apply when the power is supplied once again.

Example) Noide ID setting to 26(0x1A)

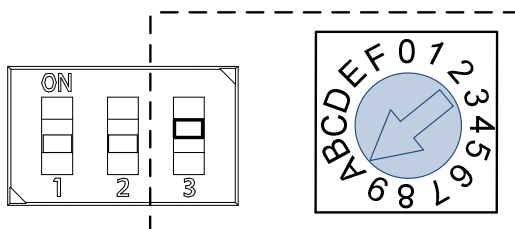

0x2004	Rotation Direction Select						ALL
Variable Format	Setting Range	Default Value	Unit	Accessi bility	PDOAllo cation	Change Property	Store
UINT	0 to 1	0	-	RW	No	Power Resupply	Yes

Sets the motor's rotation direction. If the direction is changed from the user's standpoint at the final mechanical unit, the direction can be changed through this setting.

Set Value	Descriptions
0	Positive command turns the motor counter clockwise. In this case, the position feedback value increases
1	Positive command turns the motor clockwise. In this case, the position feedback value decreases.

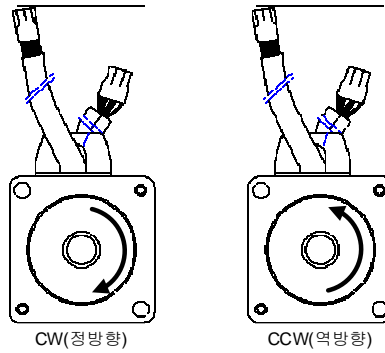

역방향: Reverse direction

0x2005	Absolute Encoder Configuration						ALL
Variable Format	Setting Range	Default Value	Unit	Accessibility	PDOAllocation	Change Property	Store
UINT	0 to 1	1	-	RW	No	Power Resupply	Yes

Sets how the absolute encoder is used

Set Value	Descriptions
0	Absolute encoder is use as absolute encoder. Multi-turn data are used.
1	Absolute encoder is use as incremental encoder. Multi-turn data are not used. Battery-related alarms/warnings are not displayed.

0x2006	Main Power Fail Check Mode						ALL
Variable Format	Setting Range	Default Value	Unit	Accessibility	PDOAllocation	Change Property	Store
UINT	0 to 255	0	-	RW	No	Servo Off	Yes

Sets the main power supply mode and counter measures to main power fail

bit	Functions	Vales	Setting Details
3~0	Main power supply setting	0	Single phase power supply
		1	3phase power supply
		2	DC power supply
7~4	Countermeasure against main power frosting	0	Sets off alarm (AL-24) in case of main power fail
		1	Sets off warning(W-01)in case of main power fail

0x2007	Main Power Fail Check Time						ALL
Variable Format	Setting Range	Default Value	Unit	Accessi bility	PDOAllo cation	Change Property	Store
UINT	0 to 5000	20	ms	RW	No	At All Times	Yes

Sets the main power fail check time. Checks the main power fail by detecting instant voltage drop, which may occur due to external power supply statuses. Please set the value appropriate for the condition of the external power supply.

0x2008	7SEG Display Selection						ALL
Variable Format	Setting Range	Default Value	Unit	Accessi bility	PDOAllo cation	Change Property	Store
UINT	0 to 100	0	-	RW	Yes	At All Times	Yes

Sets the items to display at the 7SEGwindow

Set Value	Display Item	Unit	Description
0	Operation status	-	
1	speedfeedback	rpm, mm/s	
2	speedcommand	rpm, mm/s	
3	torquefeedback	0.1%	
4	torquecommand	0.1%	
5	Accumulated operation overlaodrate	0.1%	
6	DC Link voltage	V	
7	Accumulated regeneration overlaodrate	0.1%	
8	mechanical angle	0.1deg	
9	Electrical angle	0.1deg	
10	Inertia ratio	%	
11	Drive temperature 1	°C	Temperature around the drive's power deivce
12	Drive temperature2	°C	Internal temperature of the drive
13	Encoder temperature 1	°C	Internal temperature of the encoder
14	Node ID	-	

0x2009	Regeneration brake Resistor Configuration						ALL
Variable Format	Setting Range	Default Value	Unit	Accessibility	PDOAllocation	Change Property	Store
UINT	0 to 1	0	-	RW	No	Servo Off	Yes

Settings related to regeneration brake

Set Value	Descriptions
0	Uses built-in regeneration brake
1	Uses external regeneration brake. In this case, make sure to set the regeneration brake value (0x200B) and power (0x200C) to the right values. For wiring of external regeneration brake, see 2.3 Power Unit Wiring.

0x200A	Regeneration brake Resistor Derating Factor						ALL
Variable Format	Setting Range	Default Value	Unit	Accessibility	PDOAllocation	Change Property	Store
UINT	0 to 200	100	%	RW	No	Servo Off	Yes

Sets the derating factor for regeneration brake overload check. Setting the value to 100[%] or below will set off the regeneration overload alarm (AL-23) faster. Setting the value to 100[%] above will set off the alarm slowly. Please adjust the set value in accordance with the heat protection condition of the regeneration brake. When setting the value to 100% or above, please take the heat protection condition into consideration

0x200B	Regeneration brake Resistor Value						ALL
Variable Format	Setting Range	Default Value	Unit	Accessibility	PDOAllocation	Change Property	Store
UINT	0 to 1000	0	ohm	RW	No	Servo Off	Yes

When using an external regeneration brake (0x2009=1), sets the value of the external regeneration brake by ohm. When using the built-in regeneration brake (0x2009= 0), the set value does not apply.

0x200C	Regeneration brake Resistor Power						ALL
Variable Format	Setting Range	Default Value	Unit	Accessibility	PDOAllocation	Change Property	Store
UINT	0 to 30000	0	watt	RW	No	Servo Off	Yes

When using an external regeneration brake (0x2009=1), sets the power of the external regeneration brake by watt. When using the built-in regeneration brake (0x2009= 0), the set value does not apply.

0x200D	Peak Power of Regeneration brake Resistor						ALL
Variable Format	Setting Range	Default Value	Unit	Accessibility	PDOAllocation	Change Property	Store
UINT	1 to 50000	100	watt	RW	No	Servo Off	Yes

When using an external regeneration brake (0x2009=1), sets the peak power of the external regeneration brake by ohm. When using the built-in regeneration brake (0x2009= 0), the set value does not apply.

0x200E	Duration Time @ Peak Power of Regeneration brake Resistor						ALL
Variable Format	Setting Range	Default Value	Unit	Accessibility	PDOAllocation	Change Property	Store
UINT	1 to 50000	5000	ms	RW	No	Servo Off	Yes

When using an external regeneration brake (0x2009=1), sets the duration at peak power of the external regeneration brake by ohm. When using the built-in regeneration brake (0x2009= 0), the set value does not apply.

0x200F	Overload Check Base						ALL
Variable Format	Setting Range	Default Value	Unit	Accessibility	PDOAllocation	Change Property	Store
UINT	10 to 120	100	%	RW	No	Servo Off	Yes

Shows the load rate where the operation overloads starte to accumulate. Setting the value to 100 or below will result in the overload accumulating faster from the set load rate, setting off the overlaod alarm (AL-21) faster. If the drive's heat protection condition is poor, set the value to 100% or below, so as to set off the overload alarm faster.

0x2010	Overload Warning Level						ALL
Variable Format	Setting Range	Default Value	Unit	Accessibility	PDOAllocation	Change Property	Store
UINT	10 to 100	50	%	RW	No	Servo Off	Yes

Sets the level when the accumulated operation overload warning (W10) is displayed. The warning is displayed when the accumulated operation overload (0x2603) reaches the set value. With this setting, you can be notified of the appropriate timing to take actions before the overload alarm is set off.

0x2011	PWM Off Delay Time						ALL
Variable Format	Setting Range	Default Value	Unit	Accessibility	PDOAllocation	Change Property	Store
UINT	0 to 1000	10	ms	RW	No	Servo Off	Yes

Sets the delay from servo offcommand to actual off of the PWM. When using a motor with brake installed at the vertical shaft, you can display the brake signal first and turn off the PWM after the set time, to prevent vertical slipping.

0x2012	Dynamic Brake Control Mode						ALL
Variable Format	Setting Range	Default Value	Unit	Accessibility	PDOAllocation	Change Property	Store
UINT	0 to 3	0	-	RW	No	Servo Off	Yes

Sets the dynamic brake control mode when turning off the servo

Set Value	Descriptions
0	Stop with the dynamic brake and hold
1	Stop with the dynamic brake and release
2	Stop free run and release
3	Stop free run and hold

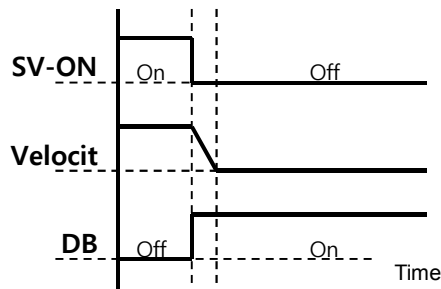

Hold after DB stop

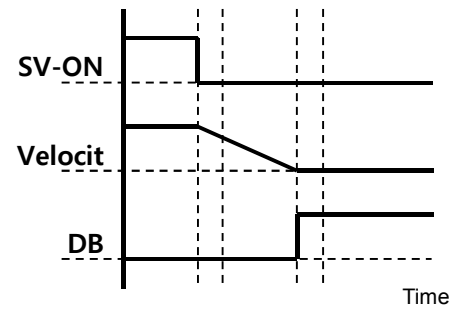

Hold after Free Run

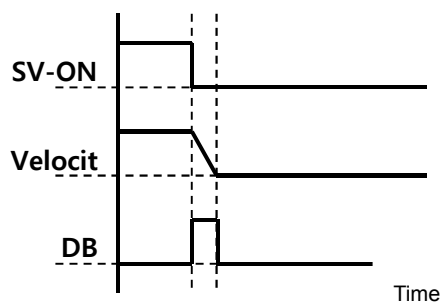

Release after DB stop

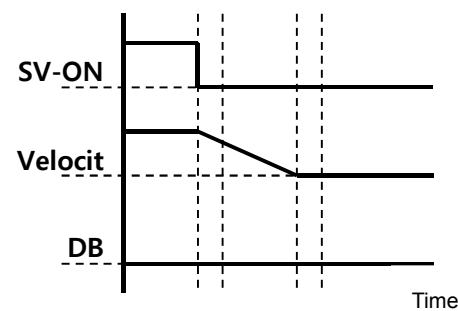

Release after Free Run

0x2013	Emergency Stop Configuration						ALL
Variable Format	Setting Range	Default Value	Unit	Accessability	PDOAllocation	Change Property	Store
UINT	0 to 1	1	-	RW	No	Servo Off	Yes

Sets how the motor stops in case of emergency stop (when POT, NOT, ESTOP is input). The deceleration/stop mode with emergency stop torque is not applied under the torque control mode.

Set Value	Descriptions
0	Stop the motor using the method set at the dynamic brake mode (0x2012) Stop the motor using the dynamic brake and maintain the torque command at 0
1	Decelerate and stop using the emergency stop torque(0x2113)

0x2014	Warning Mask Configuration	ALL
--------	----------------------------	-----

Variable Format	Setting Range	Default Value	Unit	Accessibility	PDOAllocation	Change Property	Store
UINT	0 to FFFF _{hex}	0	-	RW	Yes	At all times	Yes

In case of an alarm, the warnings masked through this setting will not set off.

bit	Warning code	WarningName
0	W01	Main power fail
1	W02	Encoder battery low
2	W04	Softwarepositionlimit
3	W08	Excessive DB current
4	W10	Operation overload
5	W20	Abnormal drive/motor combination
6	W40	Low voltage
7	W80	Emergency signal input

0x2015	U Phase Current Offset						ALL
Variable Format	Setting Range	Default Value	Unit	Accessibility	PDOAllocation	Change Property	Store
INT	-1000 to 1000	0	0.1%	RW	No	Servo Off	Yes

Manually sets the offset of the U Phase current. The set offset is subtracted from the measured current, which is applied as the actual current value. Do not attempt manual setting if you do not know the exact set value. Tuning current offset using the procedure function (0x2700 See descriptions) will allow for checking the auto-tuned values.

0x2016	V Phase Current Offset						ALL
Variable Format	Setting Range	Default Value	Unit	Accessibility	PDOAllocation	Change Property	Store
INT	-1000 to 1000	0	0.1%	RW	No	Servo Off	Yes

Manually sets the offset of the V Phase current. The set offset is subtracted from the measured current, which is applied as the actual current value. Do not attempt manual setting if you do not know the exact set value. Tuning current offset using the procedure function (0x2700 See descriptions) will allow for checking the auto-tuned values.

0x2017	W Phase Current Offset						ALL
Variable Format	Setting Range	Default Value	Unit	Accessibility	PDOAllocation	Change Property	Store
INT	-1000 to 1000	0	0.1%	RW	No	Servo Off	Yes

Manually sets the offset of the W Phase current. The set offset is subtracted from the measured current, which is applied as the actual current value. Do not attempt manual setting if you do not know the exact set value. Tuning current offset using the procedure function (0x2700 See descriptions) will allow for checking the auto-tuned values.

Medium/low-power drive(less than7.5KW) does not separately measure W phase current. Therefore, this parameter does not apply.

0x2018	Magnetic Pole Pitch						ALL
Variable Format	Setting Range	Default Value	Unit	Accessibility	PDOAllocation	Change Property	Store
UINT	1 to 65535	2400	.01mm	RW	No	Power Resupply	Yes

Sets the pitch between the magnetic poles of linear motor. Pole pitch means the distance between N polar and N polar, or S polar and S polar of magnet corresponding to electrical angle of 360.

0x2019	Linear Scale Resolution						ALL
Variable Format	Setting Range	Default Value	Unit	Accessibility	PDOAllocation	Change Property	Store
UINT	1 to 65535	1000	nm	RW	No	Power Resupply	Yes

Sets the linear scale resolution by mn Unit. In case of a linear scale having the resolution of 1um, the value is set to 1000(=1um/1nm).

0x201A	Commutation Method						ALL
Variable Format	Setting Range	Default Value	Unit	Accessibility	PDOAllocation	Change Property	Store
UINT	0 to 2	0	-	RW	No	Servo Off	Yes

Sets the method of commutation to secure the default angle information

Set Value	Descriptions
0	Commutation not necessary or commutation using the hall sensor
1	Commutation performed when the servo is turned on
2	Reserved

0x201B	Commutation Current						ALL
Variable Format	Setting Range	Default Value	Unit	Accessibility	PDOAllocation	Change Property	Store
UINT	0 to 1000	500	0.1%	RW	No	Servo Off	Yes

Set commutation current to get information for first angle of motor.

0x201C	Commutation Time						ALL
Variable Format	Setting Range	Default Value	Unit	Accessibility	PDOAllocation	Change Property	Store
UINT	500 to 5000	1000	ms	RW	No	Servo Off	Yes

Set commutation current to get information for first angle of motor.

0x201D	Grating Period of Sinusoidal Encoder						ALL
Variable Format	Setting Range	Default Value	Unit	Accessibility	PDOAllocation	Change Property	Store
UINT	1 to 65535	40	um	RW	No	Power Resupply	Yes

Set grating period of sinusoidal encoder.

0x201E	Homing Done Behaviour						ALL
Variable Format	Setting Range	Default Value	Unit	Accessibility	PDOAllocation	Change Property	Store
UINT	0 to 1	0	-	RW	No	Servo Off	Yes

Set movement towards Zero position according to home offset [0x607C].

Set Value	Descriptions
0	Motor will not move and home offset [0x607C] value will be zero position after homing by homing method [0x6098]
1	Motor will be rotate as much as home offset and zero offset will be 0, after homming by homing method [0x6098]

0x201F	Velocity Function Select						ALL
Variable Format	Setting Range	Default Value	Unit	Accessibility	PDOAllocation	Change Property	Store
UINT	0 to 2	0	-	RW	No	Always	Yes

In the case that Encoder type is Quadrature, Select the calculation mode of the feedback speed

Set Value	Descriptions
0	MT Method + Speed Observer
1	MT Method
2	M Method

0x2020	Motor Hall Phase Config						ALL
Variable Format	Setting Range	Default Value	Unit	Accessibility	PDOAllocation	Change Property	Store
UINT	0 to 1	0	-	RW	No	Power Supply	Yes

Check the motor wiring and hall sensor wiring in case of 3rd party motor and Setting the sequence of hall sensor UVW, polarity of hall sensor signal and motor rotation direction.

Set Value	Descriptions
0	Setting direction of rotation of motor (0x2004 direction of rotation of motorignal and moto
1~7	Reserved
8	Hall U polarity reversal
9	Hall V polarity reversal
10	Hall W polarity reversal
11	Reserved
12	Hall U, Hall V replace
13	Hall V, Hall W replace
14	Hall W, Hall U replace
15	Reserved

● **Gain Adjustment(0x2100~)**

0x2100	Inertia Ratio						ALL
Variable Format	Setting Range	Default Value	Unit	Accessibility	PDOAllocation	Change Property	Store
UINT	0 to 3000	100	%	RW	No	At all times	Yes

Sets the load inertia ratio to the motor rotation inertia by %.

Inertia rate = load inertia/ motor rotation inertia x 100

Load inertia rate is a very important control variable for the servo operation characteristics. The inertia ratio should be accurately set to achieve optimal servo operation. The inertial ratio can be estimated by automatic gain tuning. Real-time gain tuning will estimate the inertia continuously during operation.

0x2101	Position Loop Gain 1						ALL
Variable Format	Setting Range	Default Value	Unit	Accessibility	PDOAllocation	Change Property	Store
UINT	0 to 500	50	1/s	RW	Yes	At all times	Yes

Sets the overall responsivity of the position controller. Responsivity increases as the set value increases. Too high responsivity may cause vibration depending on the load.

0x2102	SpeedLoop Gain 1						ALL
Variable Format	Setting Range	Default Value	Unit	Accessibility	PDOAllocation	Change Property	Store
UINT	0 to 2000	75	Hz	RW	Yes	At all times	Yes

Sets the overall responsivity of the speed controller. O increase the overall system responsivity, both position loop gain and speed loop gain should be set high. Too high responsivity may cause vibration depending on the load.

0x2103	SpeedLoop Integral TimeConstant 1						ALL
Variable Format	Setting Range	Default Value	Unit	Accessibility	PDOAllocation	Change Property	Store
UINT	1 to 1000	50	ms	RW	Yes	At all times	Yes

Sets the integraltime constant of the speed controller. Higher value decreases the error under the steady state (stop or operation at regular speed). However, excessive state (acceleration/deceleration) may cause vibration..

0x2104	Torque Command Filter Time Constant 1						ALL
Variable Format	Setting Range	Default Value	Unit	Accessibility	PDOAllocation	Change Property	Store
UINT	0 to 1000	0	0.1ms	RW	Yes	At all times	Yes

Applies low passfilter to torquecommand. Application of the right value will make the torque command smoother, increasing the system's stability. However, too high value may increase the torque command delay, decreasing the system's responsivity..

0x2105	Position Loop Gain 2						ALL
Variable Format	Setting Range	Default Value	Unit	Accessibility	PDOAllocation	Change Property	Store
UINT	0 to 500	30	1/s	RW	Yes	At all times	Yes

Sets the position loop gain used as gain group 2 for gain conversion. Please see descriptions on the positionloop gain 1(0x2101).

0x2106	SpeedLoop Gain 2						ALL
Variable Format	Setting Range	Default Value	Unit	Accessibility	PDOAllocation	Change Property	Store
UINT	0 to 2000	50	Hz	RW	Yes	At all times	Yes

Sets the speed loop gain used as gain group 2 for gain conversion. Please see descriptions on the speed loop gain 1(0x2102).

0x2107	speedloopintegraltime constant 2 SpeedLoop Integral TimeConstant 2						ALL
Variable Format	Setting Range	Default Value	Unit	Accessibility	PDOAllocation	Change Property	Store
UINT	1 to 1000	50	ms	RW	Yes	At all times	Yes

Sets the speed loop integral time constantused as gain group 2 for gain conversion. Please see descriptions on the speed loop integral time constant (0x2103).

0x2108	Torque Command Filter Time Constant 2						ALL
Variable Format	Setting Range	Default Value	Unit	Accessibility	PDOAllocation	Change Property	Store
UINT	0 to 1000	0	0.1ms	RW	Yes	At all times	Yes

Sets the torque command filter time constant used as gain group 2 for gain conversion. Please see descriptions on torque command filter time constant 1(0x2104).

0x2109	Position Command Filter Time Constant						ALL
Variable Format	Setting Range	Default Value	Unit	Accessibility	PDOAllocation	Change Property	Store
UINT	0 to 10000	0	0.1ms	RW	Yes	At all times	Yes

Smooths the position command by applying low pass filter to the positioncommand. This can be used when setting the gear ratio very high.

0x210A	Position Command Average Filter Time Constant						ALL
Variable Format	Setting Range	Default Value	Unit	Accessibility	PDOAllocation	Change Property	Store
UINT	0 to 10000	0	0.1ms	RW	Yes	At all times	Yes

Smooths the position command by applying the movement average filter to the positioncommand.(To be provided in the future)

0x210B	Speed Feedback Filter Time Constant						ALL
Variable Format	Setting Range	Default Value	Unit	Accessibility	PDOAllocation	Change Property	Store
UINT	0 to 1000	2	0.1ms	RW	Yes	At all times	Yes

Applies low pass filter to speed feedback calculated from the encoder. In case of vibration due to gain when system vibration occurs or load with too large inertias applied, such vibration can be inhibited by setting the appropriate value.

0x210C	Speed Feed-forward Gain						ALL
Variable Format	Setting Range	Default Value	Unit	Accessibility	PDOAllocation	Change Property	Store
UINT	0 to 100	0	%	RW	Yes	At all times	Yes

Sets toe feed forward gain to speed command for position control. Increasing the set value reduces position error. Depending on the load, setting the value too high may cause vibration or overshoot. When tuning the gain, please increase the set value gradually.

0x210D	Speed Feed-forward Filter Time Constant						ALL
Variable Format	Setting Range	Default Value	Unit	Accessibility	PDOAllocation	Change Property	Store
UINT	0 to 1000	10	0.1ms	RW	Yes	At all times	Yes

Applies low pass filter to the compensation added to the speed command by speedfeed forward gain. Using this when a large speed feed forward gain is set or the change of position command is severe will lead to improved system stability.

0x210E	Torque Feed-forward Gain						ALL
Variable Format	Setting Range	Default Value	Unit	Accessibility	PDOAllocation	Change Property	Store
UINT	0 to 100	0	%	RW	Yes	At all times	Yes

Sets the feed forward gain to torque command for speed control.

0x210F	Torque Feed-forward Filter Time Constant						ALL
Variable Format	Setting Range	Default Value	Unit	Accessibility	PDOAllocation	Change Property	Store
UINT	0 to 1000	10	0.1ms	RW	Yes	At all times	Yes

Applies low pass filter to the compensation added to the torque command by torque feed forward gain.

0x2110	TorqueLimit Function Select						ALL
Variable Format	Setting Range	Default Value	Unit	Accessibility	PDOAllocation	Change Property	Store
UINT	0 to 4	2	-	RW	Yes	At all times	Yes

Selects the function to limit the drive's output torque.

Set Value	Descriptions
0	Torque is limited using the positive/negative torque limit value depending on the direction of rotation. The maximum value is limited by the maximum torque (0x6072) - Forward: 0x60E0, B Torque is limited using the forward/negative torque limit value depending on the direction of rotation. ackward: 0x60E1
1	The torque is limited using the torque limit value(0x6072) regardless of operation direction
2	Torque is limited using the external positive/negative torque limit value depending on the operation direction - Forward: 0x2111, Reverse: 0x2112
3	Torque is limited using the internal and external positive/negative torque limit value depending on the direction of rotation and torque limit signal. - Forward: 0x60E0(PCL without signal input), 0x2111(with PCL signal input) - Reverse: 0x60E1(NCL without signal input), 0x2112(with NCL signal input)
4	The torque is limited using the torque limit value depending on the analog input voltage. - See analogtorquelimit scale (0x221C) andoffset(0x221D)

0x2111	External Positive Torque Limit Value						ALL
Variable Format	Setting Range	Default Value	Unit	Accessi bility	PDOAllo cation	Change Property	Store
UINT	0 to 5000	3000	0.1%	RW	Yes	At all times	Yes

Sets the external positive torque limit value in accordance with the torquelimit function setting (0x2110).

0x2112	External Negative Torque Limit Value						ALL
Variable Format	Setting Range	Default Value	Unit	Accessi bility	PDOAllo cation	Change Property	Store
UINT	0 to 5000	3000	0.1%	RW	Yes	At all times	Yes

Sets the external negative torque limit value in accordance with the torque limit function setting (0x2110).

0x2113	Emergency Stop Torque						ALL
Variable Format	Setting Range	Default Value	Unit	Accessibility	PDOAllocation	Change Property	Store
UINT	0 to 5000	1000	0.1%	RW	Yes	At all times	Yes

Sets the stop torque for emergency stop (by POT, NOT, ESTOP input)

0x2114	P/PI Control Conversion Mode						ALL
Variable Format	Setting Range	Default Value	Unit	Accessibility	PDOAllocation	Change Property	Store
UINT	0 to 4	0	-	RW	Yes	At all times	Yes

Sets the PI control / P control conversion mode. Using this function improves the speed control characteristics, reducing overshoot during speed operation as well as position determination time during position operation.

Set Value	Setting Details
0	PI control at all times
1	Convert to P control when the command torque is over the P control switch torque(0x2115)
2	Convert to P control when the command speed is over the P control switch speed(0x2116)
3	Convert to P control when the acceleration command is over the P control switch speed(0x2117)
4	Convert to P control when the following error is over the P control switch following error(0x2117)

0x2115	P Control Switch Torque						ALL
Variable Format	Setting Range	Default Value	Unit	Accessibility	PDOAllocation	Change Property	Store
UINT	0 to 5000	500	0.1%	RW	Yes	At all times	Yes

See descriptions on P/PI control conversion mode (0X2114)

0x2116	P Control Switch Speed						ALL
Variable Format	Setting Range	Default Value	Unit	Accessibility	PDOAllocation	Change Property	Store
UINT	0 to 6000	100	rpm	RW	Yes	At all times	Yes

See descriptions on P/PI control conversion mode (0X2114)

0x2117	P Control Switch Acceleration						ALL
Variable Format	Setting Range	Default Value	Unit	Accessibility	PDOAllocation	Change Property	Store
UINT	0 to 60000	1000	rpm/s	RW	Yes	At all times	Yes

See descriptions on P/PI control conversion mode (0X2114)

0x2118	P Control Switch Following Error						ALL
Variable Format	Setting Range	Default Value	Unit	Accessibility	PDOAllocation	Change Property	Store
UINT	0 to 60000	100	pulse	RW	Yes	At all times	Yes

See descriptions on P/PI control conversion mode (0X2114).

0x2119	Gain Conversion Mode						ALL
Variable Format	Setting Range	Default Value	Unit	Accessibility	PDOAllocation	Change Property	Store
UINT	0 to 7	0	-	RW	Yes	At all times	Yes

Converting between two gain groups improves the overall system performance. Depending on the conversion mode, you can either manually convert through external input signal or automatically convert based on the output signal.

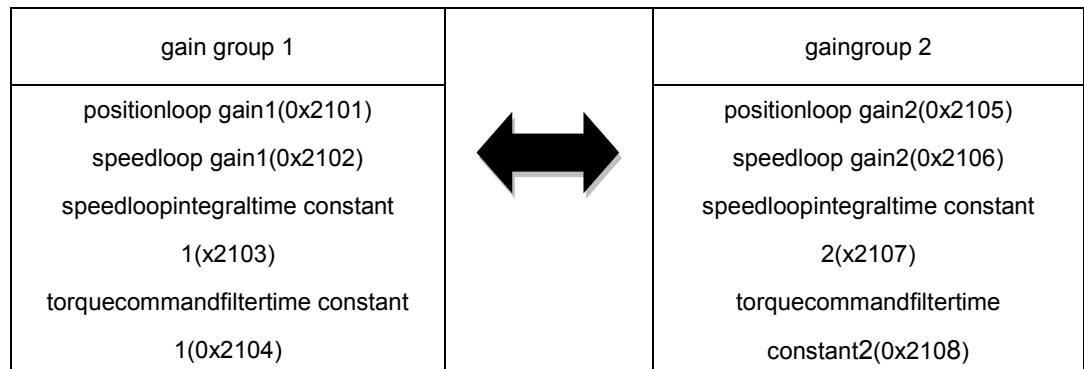

Set Value	Setting Details
0	Use only gain group 1
1	Use only gain group 2
2	Gain conversion based on GAIN2 input status - 0:use gain group 1 - 1: use gain group 2
3	Reserved
4	Reserved
5	Reserved
6	Gain conversion based on ZSPD output status - 0:use gain group 1 - 1: use gain group 2
7	Gain conversion based on INPOS1output status - 0:use gain group 1 - 1: use gain group 2

0x211A	Gain Conversion Time 1						ALL
Variable Format	Setting Range	Default Value	Unit	Accessi bility	PDOAllo cation	Change Property	Store
UINT	0 to 1000	2	ms	RW	Yes	At all times	Yes

Sets the time for conversion from gaingroup 1 to gaingroup 2

0x211B	Gain Conversion Time 2						ALL
Variable Format	Setting Range	Default Value	Unit	Accessi bility	PDOAllo cation	Change Property	Store
UINT	0 to 1000	2	ms	RW	Yes	At all times	Yes

Sets the time for conversion from gaingroup2 to gaingroup1

0x211C	Gain Conversion Waiting Time 1						ALL
Variable Format	Setting Range	Default Value	Unit	Accessi bility	PDOAllo cation	Change Property	Store
UINT	0 to 1000	0	ms	RW	Yes	At all times	Yes

Sets the waiting time before conversion from gaingroup 1 to gaingroup 2.

0x211D	Gain Conversion Waiting Time 2						ALL
Variable Format	Setting Range	Default Value	Unit	Accessibility	PDOAllocation	Change Property	Store
UINT	0 to 1000	0	ms	RW	Yes	At all times	Yes

Sets the waiting time before conversion from gaingroup2 to gaingroup1.

0x211E	Dead Band for Position Control						ALL
Variable Format	Setting Range	Default Value	Unit	Accessibility	PDOAllocation	Change Property	Store
UINT	0 to 1000	0	UU	RW	Yes	At all times	Yes

During position control, the position controller output becomes 0 if the following error for position control is under the set value.

0x211F	Drive Control Input 1						ALL
Variable Format	Setting Range	Default Value	Unit	Accessibility	PDOAllocation	Change Property	Store
UINT	0 to FFFF _{hex}	0	-	RW	Yes	At all times	No

The signal to the input contact of the drive can be input by the signal input through the I/O connector as well as by setting the bit corresponding to the input. In addition, the relevant function is activated through logical OR calculation of the signal input through the I/O connector and the bit value under this setting.

Please see the table below for input descriptions

bit	Setting Details
0	POT
1	NOT
2	HOME
3	STOP
4	PCON
5	GAIN2
6	P_CL
7	N_CL
8	MODE
9	Reserved
10	EMG
11	A_RST
12	SV_ON
13	SPD1
14	SPD2
15	SPD3

0x2120	Drive Control Input 2						ALL
Variable Format	Setting Range	Default Value	Unit	Accessibility	PDOAllocation	Change Property	Store
UINT	0 to FFFF _{hex}	0	-	RW	Yes	At all times	No

This is the same function as [0x211F], with different descriptions. Please see the table below for input descriptions

bit	Setting Details
0	START
1	PAUSE
2	REGT
3	HSTART
4	ISEL0
5	ISEL1
6	ISEL2
7	ISEL3
8	ISEL4
9	ISEL5
10	ABSRQ
11	JSTART
12	JDIR
13	PCLEAR
14	AOVR
15	Reserved

0x2121	Drive Status Output 1						ALL
Variable Format	Setting Range	Default Value	Unit	Accessibility	PDOAllocation	Change Property	Store
UINT	0 to FFFF _{hex}	0	-	RO	Yes	-	No

Other than outputting the drive's output signal status by allocating it to the I/O connector output signal, you can check the bit corresponding to the output value.

bit	Setting Details
0	BRAKE
1	ALARM
2	READY
3	ZSPD
4	INPOS1
5	TLMT
6	VLMT
7	INSPD
8	WARN
9	TGON
10	INPOS2
15-11	Reserved

0x2122	Drive Status Output 2						ALL
Variable Format	Setting Range	Default Value	Unit	Accessi- bility	PDOAllo- cation	Change Property	Store
UINT	0 to FFFF _{hex}	0	-	RO	Yes	-	No

Other than outputting the drive's output signal status by allocating it to the I/O connector output signal, you can check the bit corresponding to the output value.

bit	Setting Details
0	ORG
1	EOS
2	IOOUT0
3	IOOUT1
4	IOOUT2
5	IOOUT3
6	IOOUT4
7	IOOUT5
15~8	Reserved

● I/O Configuration(0x2200~)

0x2200	Digital Input Signal 1 Selection						ALL
Variable Format	Setting Range	Default Value	Unit	Accessability	PDOAllocation	Change Property	Store
UINT	0 to 0xFFFF	0x000F	-	RW	No	Power Resupply	Yes

Sets the function of I/Oconnector's digital input signal 1 and input signal level.

Example) when the set value is 0x006

0	0	0	6
CONTACT A		GAIN2Allocation	

bit	Setting Details
15	Signal input level setting(0:CONTACT A, 1:CONTACT B)
14~8	Reserved
7~0	Input signal allocation

Set Value	Allocationsignal
0x00	Not allocated
0x01	POT
0x02	NOT
0x03	HOME
0x04	STOP
0x05	PCON
0x06	GAIN2
0x07	P_CL
0x08	N_CL
0x09	MODE
0x0A	RESERVED
0x0B	EMG
0x0C	A_RST
0x0F	SV_ON
0x10	START
0x11	PAUSE
0x12	REGT
0x13	HSTART
0x14	ISEL0
0x15	ISEL1
0x16	ISEL2
0x17	ISEL3
0x18	ISEL4
0x19	ISEL5
0x1A	ABSRQ
0x1B	JSTART
0x1C	JDIR
0x1D	PCLR
0x1E	AOVR
0x20	SPD1
0x21	SPD2
0x22	SPD3
0x23	MODE

0x2201	Digital Input Signal 2 Selection						ALL
Variable Format	Setting Range	Default Value	Unit	Accessi bility	PDOAllo cation	Change Property	Store
UINT	0 to 0xFFFF	0x0001	-	RW	No	Power Resupply	Yes

Sets the function of I/O connector's digital input signal 2 and input signal level. Please see the descriptions 0x2200 for more detailed explanation

0x2202	Digital Input Signal 3 Selection						ALL
Variable Format	Setting Range	Default Value	Unit	Accessi bility	PDOAllo cation	Change Property	Store
UINT	0 to 0xFFFF	0x0002	-	RW	No	Power Resupply	Yes

Sets the function of I/O connector's digital input signal 3 and input signal level. Please see the descriptions 0x2200 for more detailed explanation

0x2203	Digital Input Signal 4 Selection						ALL
Variable Format	Setting Range	Default Value	Unit	Accessi bility	PDOAllo cation	Change Property	Store
UINT	0 to 0xFFFF	0x000C	-	RW	No	Power Resupply	Yes

Sets the function of I/O connector's digital input signal 4 and input signal level. Please see the descriptions 0x2200 for more detailed explanation

0x2204	Digital Input Signal 5 Selection						ALL
Variable Format	Setting Range	Default Value	Unit	Accessi bility	PDOAllo cation	Change Property	Store
UINT	0 to 0xFFFF	0x0010	-	RW	No	Power Resupply	Yes

Sets the function of I/O connector's digital input signal 6 and input signal level. Please see the descriptions 0x2200 for more detailed explanation

0x2205	Digital Input Signal 6 Selection						ALL
Variable Format	Setting Range	Default Value	Unit	Accessi bility	PDOAllo cation	Change Property	Store
UINT	0 to 0xFFFF	0x0004	-	RW	No	Power	Yes

						Resupply	
--	--	--	--	--	--	----------	--

Sets the function of I/O connector's digital input signal 6 and input signal level. Please see the descriptions 0x2200 for more detailed explanation

0x2206	Digital Input Signal 7 Selection						ALL
Variable Format	Setting Range	Default Value	Unit	Accessibility	PDOAllocation	Change Property	Store
UINT	0 to 0xFFFF	0x0012	-	RW	No	Power Resupply	Yes

Sets the function of I/O connector's digital input signal 7 and input signal level. Please see the descriptions 0x2200 for more detailed explanation

0x2207	Digital Input Signal 8 Selection						ALL
Variable Format	Setting Range	Default Value	Unit	Accessibility	PDOAllocation	Change Property	Store
UINT	0 to 0xFFFF	0x0011	-	RW	No	Power Resupply	Yes

Sets the function of I/O connector's digital input signal 8 and input signal level. Please see the descriptions 0x2200 for more detailed explanation

0x2208	Digital Input Signal 9 Selection						ALL
Variable Format	Setting Range	Default Value	Unit	Accessibility	PDOAllocation	Change Property	Store
UINT	0 to 0xFFFF	0x0003	-	RW	No	Power Resupply	Yes

Sets the function of I/O connector's digital input signal 9 and input signal level. Please see the descriptions 0x2200 for more detailed explanation

0x2209	Digital Input Signal 10 Selection						ALL
Variable Format	Setting Range	Default Value	Unit	Accessibility	PDOAllocation	Change Property	Store
UINT	0 to 0xFFFF	0x0013	-	RW	No	Power Resupply	Yes

Sets the function of I/O connector's digital input signal 10 and input signal level. Please see the descriptions 0x2200 for more detailed explanation

0x220A	Digital Input Signal 11 Selection						ALL
Variable Format	Setting Range	Default Value	Unit	Accessibility	PDOAllocation	Change Property	Store
UINT	0 to 0xFFFF	0x0014	-	RW	No	Power Resupply	Yes

Sets the function of I/O connector's digital input signal 11 and input signal level. Please see the descriptions 0x2200 for more detailed explanation

0x220B	Digital Input Signal 12 Selection						ALL
Variable Format	Setting Range	Default Value	Unit	Accessibility	PDOAllocation	Change Property	Store
UINT	0 to 0xFFFF	0x0015	-	RW	No	Power Resupply	Yes

Sets the function of I/O connector's digital input signal 12 and input signal level. Please see the descriptions 0x2200 for more detailed explanation

0x220C	Digital Input Signal 13 Selection						ALL
Variable Format	Setting Range	Default Value	Unit	Accessibility	PDOAllocation	Change Property	Store
UINT	0 to 0xFFFF	0x0016	-	RW	No	Power Resupply	Yes

Sets the function of I/O connector's digital input signal 13 and input signal level. Please see the descriptions 0x2200 for more detailed explanation

0x220D	Digital Input Signal 14 Selection						ALL
Variable Format	Setting Range	Default Value	Unit	Accessibility	PDOAllocation	Change Property	Store
UINT	0 to 0xFFFF	0x0017	-	RW	No	Power Resupply	Yes

Sets the function of I/O connector's digital input signal 14 and input signal level. Please see the descriptions 0x2200 for more detailed explanation

0x220E	Digital Input Signal 15 Selection						ALL
Variable Format	Setting Range	Default Value	Unit	Accessibility	PDOAllocation	Change Property	Store
UINT	0 to 0xFFFF	0x0018	-	RW	No	Power Resupply	Yes

Sets the function of I/O connector's digital input signal 15 and input signal level. Please see the descriptions 0x2200 for more detailed explanation

0x220F	Digital Input Signal 16 Selection						ALL
Variable Format	Setting Range	Default Value	Unit	Accessibility	PDOAllocation	Change Property	Store
UINT	0 to 0xFFFF	0x0019	-	RW	No	Power Resupply	Yes

Sets the function of I/O connector's digital input signal 16 and input signal level. Please see the descriptions 0x2200 for more detailed explanation

0x2210	Digital Output Signal 1 Selection						ALL
Variable Format	Setting Range	Default Value	Unit	Accessibility	PDOAllocation	Change Property	Store
UINT	0 to 0xFFFF	0x8002	-	RW	No	Power Resupply	Yes

Allocates the function of I/O connector's digital output signal 1, and sets the output signal level.

Example) when the set value is 0x8001

8	0	0	1
CONTACT B	BRAKEAllocation		

bit	Setting Details
15	Signal output level setting (0:CONTACT A, 1:CONTACT B)
14~8	Reserved
7~0	Output signal allocation

Set Value	AllocationSignal
0x00	Not allocated
0x01	BRAKE
0x02	ALARM
0x03	READY
0x04	ZSPD
0x05	INPOS1
0x06	TLMT
0x07	VLMT
0x08	INSPD
0x09	WARN
0x0A	TGON
0x0B	INPOS2
0x10	ORG
0x11	EOS
0x12	IOUT0
0x13	IOUT1
0x14	IOUT2
0x15	IOUT3
0x16	IOUT4
0x17	IOUT5

0x2211	Digital Output Signal 2 Selection						ALL
Variable Format	Setting Range	Default Value	Unit	Accessibility	PDOAllocation	Change Property	Store
UINT	0 to 0xFFFF	0x0003	-	RW	No	Power	Yes

						Resupply	
--	--	--	--	--	--	----------	--

Allocates the function of I/O connector's digital output signal 2, and sets the output signal level. See the descriptions on 0x2210 for more detailed explanation.

0x2212	Digital Output Signal 3 Selection						ALL
Variable Format	Setting Range	Default Value	Unit	Accessibility	PDOAllocation	Change Property	Store
UINT	0 to 0xFFFF	0x8001 _x	-	RW	No	Power Resupply	Yes

Allocates the function of I/O connector's digital output signal 3, and sets the output signal level. See the descriptions on 0x2210 for more detailed explanation.

0x2213	Digital Output Signal 4 Selection						ALL
Variable Format	Setting Range	Default Value	Unit	Accessibility	PDOAllocation	Change Property	Store
UINT	0 to 0xFFFF	0x0005	-	RW	No	Power Resupply	Yes

Allocates the function of I/O connector's digital output signal 4, and sets the output signal level. See the descriptions on 0x2210 for more detailed explanation.

0x2214	Digital Output Signal 5 Selection						ALL
Variable Format	Setting Range	Default Value	Unit	Accessibility	PDOAllocation	Change Property	Store
UINT	0 to 0xFFFF	0x0010	-	RW	No	Power Resupply	Yes

Allocates the function of I/O connector's digital output signal 5, and sets the output signal level. See the descriptions on 0x2210 for more detailed explanation.

0x2215	Digital Output Signal 6 Selection						ALL
Variable Format	Setting Range	Default Value	Unit	Accessibility	PDOAllocation	Change Property	Store
UINT	0 to 0xFFFF	0x0011	-	RW	No	Power Resupply	Yes

Allocates the function of I/O connector's digital output signal 6, and sets the output signal level. See the descriptions on 0x2210 for more detailed explanation.

0x2216		Digital Output Signal 7 Selection					ALL
Variable Format	Setting Range	Default Value	Unit	Accessi bility	PDOAllo cation	Change Property	Store
UINT	0 to 0xFFFF	0x000A	-	RW	No	Power Resupply	Yes

Allocates the function of I/O connector's digital output signal 7, and sets the output signal level. See the descriptions on 0x2210 for more detailed explanation.

0x2217		Digital Output Signal 8 Selection					ALL
Variable Format	Setting Range	Default Value	Unit	Accessi bility	PDOAllo cation	Change Property	Store
UINT	0 to 0xFFFF	0x0006	-	RW	No	Power Resupply	Yes

Allocates the function of I/O connector's digital output signal 8, and sets the output signal level. See the descriptions on 0x2210 for more detailed explanation.

0x221C		Analog Torque Input(command/limit) Scale					ALL
Variable Format	Setting Range	Default Value	Unit	Accessi bility	PDOAllo cation	Change Property	Store
UINT	0 to 0xFFFF	100	0.1%/V	RW	No	항상	Yes

When the set value of torquelimit function setting (0x2110) is 4(analogtorquelimit), the torque is limited to the analog input torque limit value. In this case, this functions sets the scale of the torque limit value..

In the case of torque control, the parameter is used as analog torque command scale. Setting value, set on the percentage of the rated torque ratio by analog input voltage $\pm 10[V]$

0x221D		Analog Torque Input(command/limit) Offset					ALL
Variable Format	Setting Range	Default Value	Unit	Accessi bility	PDOAllo cation	Change Property	Store
INT	-1000 to 1000	0	mV	RW	No	Servo Off	Yes

In the case of not torque control mode, set the analog voltage offset input by analog torque limit.

In the case of torque control mode, set analog torque command offset for this parameter

0x221E		Analog Velocity Override Mode					ALL
--------	--	-------------------------------	--	--	--	--	-----

Variable Format	Setting Range	Default Value	Unit	Accessibility	PDOAllocation	Change Property	Store
UINT	0 to 1	0	-	RW	No	Servo Off	Yes

Selects whether to use the function to override the speed by analog voltage

Set Value	Setting Details
0	Do not use analog speed override
1	Use analog speed override

0x221F	Analog Velocity Input(command/override) Offset						ALL
Variable Format	Setting Range	Default Value	Unit	Accessibility	PDOAllocation	Change Property	Store
INT	-1000 to 1000	0	mV	RW	No	Servo Off	Yes

In the case of Indexing Position control mode, set analog voltage offset input by analog velocity override,

In the case of velocity control mode, set analog velocity voltage offset input by analog velocity command.

0x2220	Analog Monitor Output Mode						P
Variable Format	Setting Range	Default Value	Unit	Accessibility	PDOAllocation	Change Property	Store
UINT	0 to 1	0	-	RW	No	At all times	Yes

The output range of analog monitor is -10~+10V. With set value of 1, only the absolute value (positive value) of the output value is displayed.

Set Value	Setting Details
0	Outputs positive/negative values
1	Outputs positive values

0x2221	Analog Monitor Channel 1 Select						P
Variable Format	Setting Range	Default Value	Unit	Accessibility	PDOAllocation	Change Property	Store
UINT	0 to 65535	0	-	RW	No	At all times	Yes

Sets the monitoring variable to output through the monitor output channel 1.

Set Value	Display item	Unit
0	speedfeedback	rpm
1	speedcommand	rpm
2	speederror	rpm
3	torquefeedback	%
4	torquecommand	%
5	positionerror	pulse
6	accumulated operation overload	%
7	DC Link voltage	V
8	accumulated regeneration overload	%
9	Encoder single-turn data	pulse
10	Inertia ratio	%
11	Full-Closed positionerror(Reserved)	UU
12	drive temperature 1	°C
13	drive temperature2	°C
14	Encoder temperature (Reserved)	°C
15	Hall sensorsignal	
16	Uphase current	A
17	V phase current	A
18	W phase current	A
19	position actual value	UU
20	position demand value	UU
21	positioncommandspeed	rpm

0x2222	Analog Monitor Channel 2 Select						P
Variable Format	Setting Range	Default Value	Unit	Accessi bility	PDOAllo cation	Change Property	Store
UINT	0 to 65535	1	-	RW	No	At all times	Yes

Sets the monitoring variable to output through the monitor output channel 2.

0x2223	Analog Monitor Channel 1 Offset						ALL
Variable Format	Setting Range	Default Value	Unit	Accessi bility	PDOAllo cation	Change Property	Store
DINT	0 to 0x40000000	0	-	RW	No	At all times	Yes

Subtracts the set offset value from the monitoring variable set for monitor output channel 1, and outputs the value. The unit is the unit of the variable set at analog monitor channel 1 setting (0x2221).

0x2224	Analog Monitor Channel 2 Offset						ALL
Variable Format	Setting Range	Default Value	Unit	Accessibility	PDOAllocation	Change Property	Store
DINT	0 to 0x40000000	0	-	RW	No	At all times	Yes

Subtracts the set offset value from the monitoring variable set for monitor output channel 2, and outputs the value. The unit is the unit of the variable set at analogmonitor channel 2 setting (0x2222).

0x2225	Analog Monitor Channel 1 Scale						ALL
Variable Format	Setting Range	Default Value	Unit	Accessibility	PDOAllocation	Change Property	Store
UDINT	0 to 0x40000000	500	-	RW	No	At all times	Yes

Sets the scaling of variables to output per 1V when outputting the monitoring variables set for analogmonitor output channel 1..The unit is the unit/1V of the variable set at analogmonitor channel 1 setting (0x2221).

For example, by setting the speed feedback to channel 1 and set the scale to 500, up to +/- 5000rpm can be output at +/-10V.

0x2226	Analog Monitor Channel 2 Scale						ALL
Variable Format	Setting Range	Default Value	Unit	Accessibility	PDOAllocation	Change Property	Store
UDINT	0 to 0x40000000	500	-	RW	No	At all times	Yes

Sets the scaling of variables to output per 1V when outputting the monitoring variables set for analog monitor output channel 2. The unit is the unit/1V of the variable set at analogmonitor channel 2 setting (0x2222).

0x2227	Analog Velocity Command Filter Time Constant						ALL
Variable Format	Setting Range	Default Value	Unit	Accessibility	PDOAllocation	Change Property	Store
UINT	0 to 1000	2	0.1ms	RW	No	At all times	Yes

As setting digital filter for analog velocity command voltage, improving the stability of command signal. If you set it too large, the delay for the torque command will be longer, reducing the system responsiveness. Therefore, set appropriate value depending on system

0x2228	Analog Torque Command Filter Time Constant						ALL
Variable Format	Setting Range	Default Value	Unit	Accessibility	PDOAllocation	Change Property	Store
UINT	0 to 1000	2	0.1ms	RW	No	At all times	Yes

As setting digital filter for analog torque command voltage, improving the stability of command signal
If you set it too large, the delay for the torque command will be longer, reducing the system responsiveness. Therefore, set appropriate value depending on system

0x2229	Analog Velocity Command Scale						ALL
Variable Format	Setting Range	Default Value	Unit	Accessibility	PDOAllocation	Change Property	Store
INT	0 to 1000	100	rpm/V	RW	No	At all times	Yes

In the case of Analog Velocity command in Velocity control mode, setting analog Velocity command value at $\pm 10[V]$ in [rpm] unit. If the value is 100, controlling 100 [rpm] per the command voltage 1[V]

0x222A	Analog Velocity Command Clamp Level						ALL
Variable Format	Setting Range	Default Value	Unit	Accessibility	PDOAllocation	Change Property	Store
UINT	0 to 1000	0	rpm	RW	No	At all times	Yes

Even if speed command on analog signal contact circuit is 0, some voltage may remain. For that case, possible to keep zero speed for the voltage command as much as setting speed

Speed Control(0x2300~)

0x2300	Jog Operation Speed						ALL
Variable Format	Setting Range	Default Value	Unit	Accessi bility	PDOAllo cation	Change Property	Store
INT	-6000 to 6000	500	rpm,	RW	No	At all times	Yes

Sets the operation speed for jog operation.

0x2301	Speed Command Acceleration Time						ALL
Variable Format	Setting Range	Default Value	Unit	Accessi bility	PDOAllo cation	Change Property	Store
UINT	0 to 10000	200	ms	RW	No	At all times	Yes

Sets the time to accelerate from 0 to the motor's rated speed by ms.

0x2302	Speed Command Deceleration Time						ALL
Variable Format	Setting Range	Default Value	Unit	Accessi bility	PDOAllo cation	Change Property	Store
UINT	0 to 10000	200	ms	RW	No	At all times	Yes

Sets the time to decelerate from the motor's rated speed to 0 by ms.

0x2303	Speed Command S-curve Time						ALL
Variable Format	Setting Range	Default Value	Unit	Accessi bility	PDOAllo cation	Change Property	Store
UINT	0 to 1000	0	ms	RW	No	At all times	Yes

For smoother acceleration/deceleration, you can set the speed command to perform S-curve pattern.If the value is 0, the motor operates in the trapezoidal.

0x2304	Program Jog Operation Speed 1						ALL
Variable Format	Setting Range	Default Value	Unit	Accessi bility	PDOAllo cation	Change Property	Store
INT	-6000 to 6000	0	rpm	RW	No	At all times	Yes

For program jog operation, you can set operation speed 1~4 and operation time 1~4 for each operation speed.

0x2305	Program Jog Operation Speed 2						ALL
Variable Format	Setting Range	Default Value	Unit	Accessibility	PDOAllocation	Change Property	Store
INT	-6000 to 6000	500	rpm	RW	No	At all times	Yes

Please see descriptions on speed 1(0x2304).

0x2306	Program Jog Operation Speed 3						ALL
Variable Format	Setting Range	Default Value	Unit	Accessibility	PDOAllocation	Change Property	Store
INT	-6000 to 6000	0	rpm	RW	No	At all times	Yes

Please see descriptions on speed 1(0x2304).

0x2307	Program Jog Operation Speed 4						ALL
Variable Format	Setting Range	Default Value	Unit	Accessibility	PDOAllocation	Change Property	Store
INT	-6000 to 6000	-500	rpm	RW	No	At all times	Yes

Please see descriptions on speed 1(0x2304).

0x2308	Program Jog Operation Time 1						ALL
Variable Format	Setting Range	Default Value	Unit	Accessibility	PDOAllocation	Change Property	Store
UINT	0 to 10000	500	ms	RW	No	At all times	Yes

Please see descriptions on speed 1(0x2304).

0x2309	Program Jog Operation Time 2						ALL
Variable Format	Setting Range	Default Value	Unit	Accessibility	PDOAllocation	Change Property	Store
UINT	0 to 10000	5000	ms	RW	No	At all times	Yes

Please see descriptions on speed 1(0x2304).

0x230A	Program Jog Operation Time 3						ALL
Variable Format	Setting Range	Default Value	Unit	Accessibility	PDOAllocation	Change Property	Store
UINT	0 to 10000	500	ms	RW	No	At all times	Yes

Please see descriptions on speed 1(0x2304).

0x230B	Program Jog Operation Time 4						ALL
Variable Format	Setting Range	Default Value	Unit	Accessibility	PDOAllocation	Change Property	Store
UINT	0 to 10000	5000	ms	RW	No	At all times	Yes

Please see descriptions on speed 1(0x2304).

0x230C	Index Pulse Search Speed						ALL
Variable Format	Setting Range	Default Value	Unit	Accessibility	PDOAllocation	Change Property	Store
INT	-1000 to 1000	20	rpm	RW	No	Servo Off	Yes

Sets the index pulse search speed.

0x230D	Speed Limit Function Select						ALL
Variable Format	Setting Range	Default Value	Unit	Accessibility	PDOAllocation	Change Property	Store
UINT	0 to 3	0	-	RW	No	Servo Off	Yes

Sets the speed limit function for torque control.

Set Value	Setting Details
0	Limited to the limit speed value (0x230E)
1	Limited to the motor's maximum speedspeed

0x230E	Speed Limit Value at Torque Control Mode						ALL
Variable Format	Setting Range	Default Value	Unit	Accessibility	PDOAllocation	Change Property	Store
UINT	0 to 6000	1000	rpm	RW	Yes	At all times	Yes

Sets the limit speed value for torquecontrol. It only applies when the speed limit function setting(0x230D) is set to 0.

0x230F	Over Speed Dection Level						ALL
Variable Format	Setting Range	Default Value	Unit	Accessi bility	PDOAllo cation	Change Property	Store
UINT	0 to 10000	6000	rpm	RW	No	At all times	Yes

Sets the detection level for the excessivespeed alarm (AL-50).When the set value is higher than the motor’s maximum speed, the detection level is determined by the motor’s maximum speed

0x2310	Excessive Speed Error Detection Level						ALL
Variable Format	Setting Range	Default Value	Unit	Accessi bility	PDOAllo cation	Change Property	Store
UINT	0 to 10000	5000	rpm	RW	No	At all times	Yes

Setst the detection level for excessive speed error (AL-53). Excessive speed error occurs when the errors of speedcommandandspeedfeedback exceed the set.

0x2311	Servo-Lock Function Select						ALL
Variable Format	Setting Range	Default Value	Unit	Accessi bility	PDOAllo cation	Change Property	Store
UINT	0 to 1	0	-	RW	No	At all times	Yes

Sets the servo-lock function, which fixes the motor’s position to the position value at the time when the speed command for velicity control is 0.

Set Value	Setting Details
0	Do not use servo-lock function
1	Use servo-lock function

0x2312	Multi-Step Operation Speed 1						ALL
Variable Format	Setting Range	Default Value	Unit	Accessi bility	PDOAllo cation	Change Property	Store
INT	-32768 to 32767	0	rpm	RW	No	At all times	Yes

Setting for Multi-Step Operation Speed 1 in Velocity operation mode. It is the speed when input contact SPD1, SPD2 and SPD3 are OFF

0x2313	Multi-Step Operation Speed 2						ALL
Variable Format	Setting Range	Default Value	Unit	Accessi bility	PDOAllo cation	Change Property	Store
INT	-32768 to 32767	10	rpm	RW	No	At all times	Yes

Setting for Multi-Step Operation Speed 2 in Velocity operation mode. It is the speed when input contact SPD1 is ON while SPD2 and SPD3 are OFF

0x2314	Multi-Step Operation Speed 3						ALL
Variable Format	Setting Range	Default Value	Unit	Accessi bility	PDOAllo cation	Change Property	Store
INT	-32768 to 32767	50	rpm	RW	No	At all times	Yes

Setting for Multi-Step Operation Speed 3 in Velocity operation mode. It is the speed when input contact SPD2 is ON while SPD1 and SPD3 are OFF

0x2315	Multi-Step Operation Speed 4						ALL
Variable Format	Setting Range	Default Value	Unit	Accessi bility	PDOAllo cation	Change Property	Store
INT	-32768 to 32767	100	rpm	RW	No	At all times	Yes

Setting for Multi-Step Operation Speed 4 in Velocity operation mode. It is the speed when input contact SPD1 and SPD2 are ON while SPD3 are OFF

0x2316	Multi-Step Operation Speed 5						ALL
Variable Format	Setting Range	Default Value	Unit	Accessi bility	PDOAllo cation	Change Property	Store
INT	-32768 to 32767	200	rpm	RW	No	At all times	Yes

Setting for Multi-Step Operation Speed 5 in Velocity operation mode. It is the speed when input contact SPD3 is ON while SPD1 and SPD2 are OFF

0x2317	Multi-Step Operation Speed 6						ALL
Variable Format	Setting Range	Default Value	Unit	Accessi bility	PDOAllo cation	Change Property	Store

INT	-32768 to 32767	500	rpm	RW	No	At all times	Yes
-----	-----------------	-----	-----	----	----	--------------	-----

Setting for Multi-Step Operation Speed 6 in Velocity operation mode. It is the speed when input contact SPD1 and SPD3 are ON while SPD3 is OFF

0x2318	Multi-Step Operation Speed 7						ALL
Variable Format	Setting Range	Default Value	Unit	Accessi bility	PDOAllo cation	Change Property	Store
INT	-32768 to 32767	1000	rpm	RW	No	At all times	Yes

Setting for Multi-Step Operation Speed 7 in Velocity operation mode. It is the speed when input contact SPD2 and SPD3 are ON while SPD1 is OFF

0x2319	Multi-Step Operation Speed 8						ALL
Variable Format	Setting Range	Default Value	Unit	Accessi bility	PDOAllo cation	Change Property	Store
INT	-32768 to 32767	1500	rpm	RW	No	At all times	Yes

Setting for Multi-Step Operation Speed 8 in Velocity operation mode. It is the speed when input contact SPD1, SPD2 and SPD3 are OFF

0x231A	Velocity Command Switch Select						ALL
Variable Format	Setting Range	Default Value	Unit	Accessi bility	PDOAllo cation	Change Property	Store
UINT	0 to 3	0	-	RW	No	At all times	Yes

Select velocity command method in velocity control mode

Set Value	Setting Details
0	Use Analoge speed command
1	Use input contact SPD1, SPD2 and Analog command speed.
2	Use input contact SPD1, SPD2, SPD3 and Analog speed command
3	Use input contact SPD1, SPD2, SPD3 Speed

Use Analog speed command when the contact is on after setting the vlaule, 1 or 2.

Use Analog speed command when the contact is on after setting the vlaule, 1 or 2.

Ex 1) Set value is 2 and, Inpt Analog command 10[V] in the state that SPD1 and SPD2 are on

Operating motor speed is 100[rpm] and not available analog input command speed

Operating speed is operated by multistep command speed in the set value of parameter

0x2315

Ex 2) Set value is 2 and, Inpt Analog command 10[V] in the state that SPD1, SPD2 and SPD3 are on

Operating motor speed is 1000[rpm] and not available digital input command speed

Operating speed is operated by analog speed command voltage in the set value of parameter 0x2229

Ex 2) Set value is 2 and, Inpt Analog command 10[V] in the state that SPD1, SPD2 and SPD3 are on

Operating motor speed is 1000[rpm] and not available digital input command speed

Operating speed is operated by analog speed command voltage in the set value of parameter 0x2229

• Miscellaneous Setting(0x2400~)

0x2400	Software Position Limit Function Select						ALL
Variable Format	Setting Range	Default Value	Unit	Accessibility	PDOAllocation	Change Property	Store
UINT	0 to 3	0	-	RW	No	At all times	Yes

Sets the software position limit function for position control. When using the position limit function, the upper limit and the lower limit are limited to the values set at (0x607D:02) and (0x607D:01), respectively. The software position limit function does not work before the homing action. The function does not work when the upper limit is lower than the lower limit.

Set Value	Setting Details
0	Do not use either positive or negative software position limit
1	Use only positive software position limit. Negative position is not limited
2	Use only negative software position limit. Positive position is not limited
3	Use both positive and negative software position limit

0x2401	INPOS1 Output Range						P
Variable Format	Setting Range	Default Value	Unit	Accessibility	PDOAllocation	Change Property	Store
UINT	0 to 60000	100	UU	RW	Yes	At all times	Yes

The INPOS1 signal is displayed when the following error is kept within the INPOS1's output range and maintained during the INPOS1 output time without positioncommand update.

0x2402	INPOS1 Output Time						P
Variable Format	Setting Range	Default Value	Unit	Accessibility	PDOAllocation	Change Property	Store
UINT	0 to 1000	0	ms	RW	Yes	At all times	Yes

See descriptions on 0x2401.

0x2403	INPOS2 Output Range						P
Variable Format	Setting Range	Default Value	Unit	Accessibility	PDOAllocation	Change Property	Store
UINT	0 to 60000	100	UU	RW	Yes	At all times	Yes

INPOS2 signal is displayed when the following error is below the set value. Unlike INPOS1, the INPOS2 signal is output after calculating only the following error

0x2404	ZSPD Output Range						P
--------	-------------------	--	--	--	--	--	---

Variable Format	Setting Range	Default Value	Unit	Accessibility	PDOAllocation	Change Property	Store
UINT	0 to 6000	10	rpm	RW	Yes	At all times	Yes

ZSPD signal is output when the current speed is smaller than the set value.

0x2405 TGON Output Range							
Variable Format	Setting Range	Default Value	Unit	Accessibility	PDOAllocation	Change Property	Store
UINT	0 to 6000	100	rpm	RW	Yes	At all times	Yes

TGON signal is output when the current speed is smaller than the set value.

0x2406 INSPD Output Range							
Variable Format	Setting Range	Default Value	Unit	Accessibility	PDOAllocation	Change Property	Store
UINT	0 to 6000	100	rpm	RW	Yes	At all times	Yes

INSPD signal is output when the current speed is smaller than the set value.

0x2407 BRAKE Output Speed							
Variable Format	Setting Range	Default Value	Unit	Accessibility	PDOAllocation	Change Property	Store
UINT	0 to 6000	100	rpm	RW	No	Servo Off	Yes

When the motor stops due to servo-off or servo alarm, you can set the output timing by setting the brake signal output speed(0x2407) and delay time(0x2408). When the motor's rotational speed is under the set speed(0x2407), or the output delay time (0x2408) lapses after servo off command, the brake signal is output.

0x2408 BRAKE Output Delay Time							
Variable Format	Setting Range	Default Value	Unit	Accessibility	PDOAllocation	Change Property	Store
UINT	0 to 1000	100	ms	RW	No	Servo Off	Yes

See descriptions on 0x2407

0x2409 Torque Limit at Homing Using Stopper							
Variable	Setting Range	Default	Unit	Accessibility	PDOAllocation	Change	Store
							ALL

Format		Value		bility	cation	Property	
UINT	0 to 2000	250	0.1%	RW	No	Power Resupply	Yes

Sets the torque limit when homing using stopper. Setting the value too high may damage the machine when hitting the stopper. Please take caution.

0x240A	Duration Time at Homing Using Stopper						ALL
Variable Format	Setting Range	Default Value	Unit	Accessi bility	PDOAllo cation	Change Property	Store
UINT	0 to 1000	50	ms	RW	No	Power Resupply	Yes

Sets the stopper detection time when homing using stopper. Please set the appropriate value for the machine.

0x240B	Modulo Mode						ALL
Variable Format	Setting Range	Default Value	Unit	Accessi bility	PDOAllo cation	Change Property	Store
UINT	0 to 3	0	-	RW	No	Servo Off	Yes

Selects whether to use Modulo function (L7P is determined depending on coordinate shaft and Index type)

Set Value	Setting Details
0	Do not use Modulo function
1	Move forward using Modulo function
2	Move reverse using Modulo function
3	Note in the direction of the shortest distance using Modulo function

0x240C	Modulo Factor						ALL
Variable Format	Setting Range	Default Value	Unit	Accessi bility	PDOAllo cation	Change Property	Store
DINT	1 to 0x3FFFFFFF	3600	UU	RW	No	Servo Off	Yes

Sets the Modulo factor. Sets the position value corresponding to 1 rotation when the user drives the motor.

0x240D	User Drive Name						ALL
Variable Format	Setting Range	Default Value	Unit	Accessi bility	PDOAllo cation	Change Property	Store

STRING	-	'Drive'	UU	RW	No	Servo Off	Yes
--------	---	---------	----	----	----	-----------	-----

The user can define the drive name upto 16 characters.

0x240E	Individual Parameter Store						ALL
Variable Format	Setting Range	Default Value	Unit	Accessi bility	PDOAllo cation	Change Property	Store
UINT	0 to 1	0	-	RW	No	At all times	No

Selects whether to store the parameters individually. This parameter is not stored, and goes back to 0 when the power is turned on.

Set Value	Setting Details
0	Do not individually store parameters. See parameter store 0x1010)for parameters storing.
1	Individually store parameters. Parameters are automatically stored.

- Enhanced Control(0x2500~)

0x2500	Adaptive Filter Function Select						ALL
Variable Format	Setting Range	Default Value	Unit	Accessibility	PDOAllocation	Change Property	Store
UINT	0 to 5	0	-	RW	No	Servo Off	Yes

Sets the function of adaptivefilter

Set Value	Setting Details
0	Do not use adaptive filter
1	Use only 1 adaptive filter. The automatically set value can be viewed at notchfilter 4 setting (0x250A, 0x250B).
2	Use only 2 adaptive filter. The automatically set value can be viewed at notchfilter 4 setting (0x250A, 0x250B).
3~5	Reserved

0x2501	Notch Filter 1 Frequency						ALL
Variable Format	Setting Range	Default Value	Unit	Accessibility	PDOAllocation	Change Property	Store
UINT	50 to 5000	5000	Hz	RW	No	Servo Off	Yes

Sets notchfilter 1 frequency

0x2502	Notch Filter 1 Width						ALL
Variable Format	Setting Range	Default Value	Unit	Accessibility	PDOAllocation	Change Property	Store
UINT	1 to 100	1	Hz	RW	No	Servo Off	Yes

Sets notch filter 1 width

0x2503	Notch Filter 1 Depth						ALL
Variable Format	Setting Range	Default Value	Unit	Accessibility	PDOAllocation	Change Property	Store
UINT	1 to 5	1	-	RW	No	Servo Off	Yes

Sets notch filter 1 depth

0x2504	Notch Filter 2 Frequency						ALL
Variable Format	Setting Range	Default Value	Unit	Accessibility	PDOAllocation	Change Property	Store
UINT	50 to 5000	5000	Hz	RW	No	Servo Off	Yes

0x2505	Notch Filter 2 Width						ALL
Variable Format	Setting Range	Default Value	Unit	Accessibility	PDOAllocation	Change Property	Store
UINT	1 to 100	1	Hz	RW	No	Servo Off	Yes

0x2506	Notch Filter 2 Depth						ALL
Variable Format	Setting Range	Default Value	Unit	Accessibility	PDOAllocation	Change Property	Store
UINT	1 to 5	1	-	RW	No	Servo Off	Yes

0x2507	Notch Filter 3 Frequency						ALL
Variable Format	Setting Range	Default Value	Unit	Accessibility	PDOAllocation	Change Property	Store
UINT	50 to 5000	5000	Hz	RW	No	Servo Off	Yes

0x2508	Notch Filter 3 Width						ALL
Variable Format	Setting Range	Default Value	Unit	Accessibility	PDOAllocation	Change Property	Store
UINT	1 to 100	1	Hz	RW	No	Servo Off	Yes

0x2509	Notch Filter 3 Depth						ALL
Variable Format	Setting Range	Default Value	Unit	Accessibility	PDOAllocation	Change Property	Store
UINT	1 to 5	1	-	RW	No	Servo Off	Yes

0x250A		Notch Filter 4 Frequency					ALL
Variable Format	Setting Range	Default Value	Unit	Accessibility	PDOAllocation	Change Property	Store
UINT	50 to 5000	5000	Hz	RW	No	Servo Off	Yes

0x250B		Notch Filter 4 Width					ALL
Variable Format	Setting Range	Default Value	Unit	Accessibility	PDOAllocation	Change Property	Store
UINT	1 to 100	1	Hz	RW	No	Servo Off	Yes

0x250C		Notch Filter 4 Depth					ALL
Variable Format	Setting Range	Default Value	Unit	Accessibility	PDOAllocation	Change Property	Store
UINT	1 to 5	1	-	RW	No	Servo Off	Yes

0x250D		On-line Gain Tuning Mode					ALL
Variable Format	Setting Range	Default Value	Unit	Accessibility	PDOAllocation	Change Property	Store
UINT	0 to 1	0	-	RW	No	Servo Off	Yes

Sets on-line gain tuning mode.

Set Value	Setting Details
0	Do not use online gain tuning
1	Use online gain tuning

0x250E		System Rigidity for Gain Tuning					ALL
Variable Format	Setting Range	Default Value	Unit	Accessibility	PDOAllocation	Change Property	Store
UINT	1 to 20	5	-	RW	No	Servo Off	Yes

Sets the system rigidity to apply for gaintuning. This setting increases or decreases the overall gain after gain tuning. If the gain of the maximum set value is not sufficient, please use manual tuning. Automatically changed gains after gain tuning are as follows.

Inertia ratio (0x2100), positionloop gain 1(0x2001), speedloop gain 1(0x2102), speedintegralttime constant 1(0x2103), torquecommandfiltertime constant 1(0x2104), notchfilter 3 frequency(0x2507, TBD), notchfilter 4 frequency(0x250A, TBD)

0x250F	On-line Gain Tuning Adaptation Speed						ALL
Variable Format	Setting Range	Default Value	Unit	Accessi bility	PDOAllo cation	Change Property	Store
UINT	1 to 5	1	-	RW	No	Servo Off	Yes

Sets the speed at which the gain chage is reflectedduring gain tuning. The higher the set value, the faster the gain change is applied.

0x2510	Off-line Gain Tuning Direction						ALL
Variable Format	Setting Range	Default Value	Unit	Accessi bility	PDOAllo cation	Change Property	Store
UINT	0 to 1	0	-	RW	No	Servo Off	Yes

Sets the movement direction for off line gain tuning.Please use the appropriate setting that fits the mechanical unit.

Set Value	Setting Details
0	Forward operation
1	Reverse operation

0x2511	Off-line Gain Tuning Distance						ALL
Variable Format	Setting Range	Default Value	Unit	Accessi bility	PDOAllo cation	Change Property	Store
UINT	1 to 10	5	-	RW	No	Servo Off	Yes

Sets the distance for offline gain tuning. Higher set value means longer movement distance. Please use the appropriate setting that fits the mechanical unit. Secure sufficient distance before tuning (1 rotation or longer).

0x2512	Disturbance Observer Gain						ALL
Variable Format	Setting Range	Default Value	Unit	Accessi bility	PDOAllo cation	Change Property	Store
UINT	0 to 100	0	%	RW	No	Servo Off	Yes

(to be provided in the future)

0x2513	Disturbance Observer Filter Time Constant						ALL
Variable Format	Setting Range	Default Value	Unit	Accessi bility	PDOAllo cation	Change Property	Store
UINT	0 to 1000	10	0.1ms	RW	No	Servo Off	Yes

(to be provided in the future)

0x2514		Current Controller Gain					ALL
Variable Format	Setting Range	Default Value	Unit	Accessibility	PDOAllocation	Change Property	Store
UINT	1 to 150	100	%	RW	No	Servo Off	Yes

Sets the gain of the current controller. Lowering the set value reduces the noise, but also decreases the drive's responsiveness.

0x2515		Vibration Supression Filter Configuration					ALL
Variable Format	Setting Range	Default Value	Unit	Accessibility	PDOAllocation	Change Property	Store
UINT	0 to 5	0	-	RW	No	Servo Off	Yes

Reserved

0x2516		Vibration Supression Filter 1 Frequency					ALL
Variable Format	Setting Range	Default Value	Unit	Accessibility	PDOAllocation	Change Property	Store
UINT	0 to 2000	0	0.1Hz	RW	No	Servo Off	Yes

Reserved

0x2517		Vibration Supression Filter 1 Damping					ALL
Variable Format	Setting Range	Default Value	Unit	Accessibility	PDOAllocation	Change Property	Store
UINT	0 to 5	0	-	RW	No	Servo Off	Yes

Reserved

0x2518		Vibration Supression Filter 2 Frequency					ALL
Variable Format	Setting Range	Default Value	Unit	Accessibility	PDOAllocation	Change Property	Store
UINT	1 to 2000	0	0.1Hz	RW	No	Servo Off	Yes

Reserved

0x2519	Vibration Supression Filter 2 Damping						ALL
Variable Format	Setting Range	Default Value	Unit	Accessi bility	PDOAllo cation	Change Property	Store
UINT	0 to 5	0	-	RW	No	Servo Off	Yes

Reserved

● Monitoring(0x2600~)

0x2600	Feedback Speed						ALL
Variable Format	Setting Range	Default Value	Unit	Accessi bility	PDOAllo cation	Change Property	Store
INT	-	-	rpm	RO	Yes	-	No

Shows the motor's current rotational speed.

0x2601	commandspeed Command Speed						ALL
Variable Format	Setting Range	Default Value	Unit	Accessi bility	PDOAllo cation	Change Property	Store
INT	-	-	rpm	RO	Yes	-	No

Shows the speedcommand input in th the drive's speed control loop.

0x2602	Following Error						ALL
Variable Format	Setting Range	Default Value	Unit	Accessi bility	PDOAllo cation	Change Property	Store
DINT	-	-	pulse	RO	Yes	-	No

Shows position error for position control

0x2603	Accumulated Operation Overload						ALL
Variable Format	Setting Range	Default Value	Unit	Accessi bility	PDOAllo cation	Change Property	Store
INT	-	-	0.1%	RO	No	-	No

Shows the accumulated operation overload ratio. When the operation overload ratioreaches the set warning level (0x2010), the operation overload warning (W10) sets off. When it reaches 100%, operation overload alarm (AL-21) set s off.

0x2604	Instantaneous Maximum Operation Overload						ALL
Variable Format	Setting Range	Default Value	Unit	Accessi bility	PDOAllo cation	Change Property	Store
INT	-	-	0.1%	RO	Yes	-	No

Shows the instantaneous maximum of operation overload ratio from the drive.This value can be reset by resetting the instantaneous maximum operation overload.

0x2605	DC-Link Voltage						ALL
Variable Format	Setting Range	Default Value	Unit	Accessibility	PDOAllocation	Change Property	Store
UINT	-	-	Volt	RO	Yes	-	No

Shows DC-Link voltage based on power input.

0x2606	Accumulated Regeneration Overload						ALL
Variable Format	Setting Range	Default Value	Unit	Accessibility	PDOAllocation	Change Property	Store
INT	-	-	0.1%	RO	No	-	No

Shows the accumulated regeneration overload of the regeneration brake due to regeneration operation. When the value reaches 100%, regeneration overload alarm (AL-23) set s off.

0x2607	SingleTurn Data						ALL
Variable Format	Setting Range	Default Value	Unit	Accessibility	PDOAllocation	Change Property	Store
UDINT	-	-	pulse	RO	Yes	-	No

Shows the motor's single turn data. The values are from 0 ~ (encoder resolution-1)

0x2608	Mechanical Angle						ALL
Variable Format	Setting Range	Default Value	Unit	Accessibility	PDOAllocation	Change Property	Store
UINT	-	-	0.1deg	RO	Yes	-	No

The motor's single turn data is represented within the 0.0~359.9range.

0x2609	Electrical Angle						ALL
Variable Format	Setting Range	Default Value	Unit	Accessibility	PDOAllocation	Change Property	Store
INT	-	-	0.1deg	RO	Yes	-	No

Shows the motor's electrical angle within the range of -180.0~180.0.

0x260A	MultiTurn Data						ALL
Variable Format	Setting Range	Default Value	Unit	Accessibility	PDOAllocation	Change Property	Store
DINT	-	-	rev.	RO	Yes	-	No

Shows the multi-turn data of multi-turn encoder.

0x260B	Drive Temperature 1						ALL
Variable Format	Setting Range	Default Value	Unit	Accessibility	PDOAllocation	Change Property	Store
INT	-	-	°C	RO	No	-	No

The temperature is measured with the built in temperature sensor in the drive's power board. When the measured value is 95 or above, the drive overheating alarm 1(AL-22) is set off.

0x260C	2 Drive Temperature 2						ALL
Variable Format	Setting Range	Default Value	Unit	Accessibility	PDOAllocation	Change Property	Store
INT	-	-	°C	RO	No	-	No

The temperature is measured with the built in temperature sensor in the drive's power board. When the measured value is 90 or above, the drive overheating alarm 1(AL-25) is set off.

0x260D	Encoder Temperature						ALL
Variable Format	Setting Range	Default Value	Unit	Accessibility	PDOAllocation	Change Property	Store
INT	-	-	°C	RO	No	-	No

Shows the temperature measured by the built in sensor of serial encoders (when encoder format (0x0201) is 4). When the measured 90 or above, the encoder heat (AL-26) sets off.

0x260E	Motor Rated Speed						ALL
Variable Format	Setting Range	Default Value	Unit	Accessibility	PDOAllocation	Change Property	Store
UINT	-	-	rpm	RO	No	-	No

Shows the rated speed of the drive motor.

0x260F	motor최대speed Motor Maximum Speed						ALL
Variable Format	Setting Range	Default Value	Unit	Accessi bility	PDOAllo cation	Change Property	Store
UINT	-	-	rpm	RO	No	-	No

Shows the drive's maximum speed.

0x2610	Drive Rated Current						ALL
Variable Format	Setting Range	Default Value	Unit	Accessi bility	PDOAllo cation	Change Property	Store
UINT	-	-	0.1A	RO	No	-	No

Shows the drive's rated current.

0x2611	FPGA Version						ALL
Variable Format	Setting Range	Default Value	Unit	Accessi bility	PDOAllo cation	Change Property	Store
STRING	-	-	-	RO	No	-	No

Shows the version of FPGA within the drive.

0x2612	Hall Signal Display						ALL
Variable Format	Setting Range	Default Value	Unit	Accessi bility	PDOAllo cation	Change Property	Store
UINT	-	-	-	RO	No	-	No

Shows the hall signal of the hall sensor attached to the encoder (or motor). You can use this function to check the hall sensor connection and compare the U/A/V phase of the motor and the signal's direction

Signal values of 5→4→6→2→3→1 are repeated when rotating forward, and 1→3→2→6→4→5 are repeated when moving backwards

bit	Setting Details
0	Wphasesignal
1	V phasesignal
2	U phase signal

0x2613	Bootloader Version						ALL
Variable Format	Setting Range	Default Value	Unit	Accessibility	PDOAllocation	Change Property	Store
STRING	-	-	-	RO	No	-	No

Shows the drive's boot loader version.

0x2614	WarningCode						ALL
Variable Format	Setting Range	Default Value	Unit	Accessibility	PDOAllocation	Change Property	Store
UINT	-	-	-	RO	Yes	-	No

Shows the warning code.

0x2615	Analog Input Channel 1 Value						ALL
Variable Format	Setting Range	Default Value	Unit	Accessibility	PDOAllocation	Change Property	Store
INT	-	-	mV	RO	Yes	-	No

Shows the analog torque input voltage by mV

0x2616	Analog Input Channel 2 Value						ALL
Variable Format	Setting Range	Default Value	Unit	Accessibility	PDOAllocation	Change Property	Store
INT	-	-	mV	RO	Yes	-	No

Shows the analog speed override input voltage by mV

Procedure and Alarm history (0x2700~)

0x2700	Procedure Command Code						ALL
Variable Format	Setting Range	Default Value	Unit	Accessi bility	PDOAllo cation	Change Property	Store
UINT	0 to 0xFFFF	0	-	RW	No	-	No

A variety of procedures can be performed by the following procedurecommand codes and command factors. As the command code refer to the command factors when input, the factor command should be filled with the right values before inputting command codes

Commandcodes	commandfactors	Execution Procedure
Manual jog (0x0001)	1	Servo On
	2	Servo Off
	3	Positive Operation (0x2300)
	4	Negative Operation(0x2300)
	5	0speedStop
Program jog (0x0002)	1	Servo On
	2	Servo Off
	3	Operation Stop
	4	0speedStop (maintain Servo On)
Servo alarm history reset (0x0003)	1	
Offline duration (0x0004)	1	Auto Tuning Start
Indexpulse search (0x0005)	1	Servo On
	2	Servo Off
	3	Positive Search (0x230C)
	4	Negative Search (0x230C)
	5	0speedStop
Absolute encoder reset (0x0006)	1	Absolute Encoder Reset
Instantaneous maximumoperation overload reset(0x0007)	1	Reset instantaneous maximum operation overload value (0x2604)
Phase current offset device. (0x0008)	1	Adjust phase current offset (U/V/W phase offset are stored in 0x2015~0x2017, respectively. AL-15 sets off when the offset is abnormally large)
Software Reset	1	Software reset

(0x0009)		
Commutation (0x000A)	1	Perform commutation

0x2701	Procedure Command Argument						ALL
Variable Format	Setting Range	Default Value	Unit	Accessibility	PDOAllocation	Change Property	Store
UINT	0 to FFFF _{hex}	0	-	RW	No	-	No

0x2702	Servo Alarm History						ALL
SubIndex 0		Number of Entries					
Variable Format	Setting Range	Default Value	Unit	Accessibility	PDOAllocation	Change Property	Store
STRING	-	16	-	RO	No	-	No
SubIndex 1		Alarm Code 1(newest)					
Variable Format	Setting Range	Default Value	Unit	Accessibility	PDOAllocation	Change Property	Store
STRING	-	-	-	RO	No	-	No
SubIndex 2		Alarm Code 2					
Variable Format	Setting Range	Default Value	Unit	Accessibility	PDOAllocation	Change Property	Store
STRING	-	-	-	RO	No	-	No
SubIndex 3		Alarm Code 3					
Variable Format	Setting Range	Default Value	Unit	Accessibility	PDOAllocation	Change Property	Store
STRING	-	-	-	RO	No	-	No
SubIndex 4		Alarm Code 4					
Variable Format	Setting Range	Default Value	Unit	Accessibility	PDOAllocation	Change Property	Store
STRING	-	-	-	RO	No	-	No
SubIndex 5		Alarm Code 5					
Variable Format	Setting Range	Default Value	Unit	Accessibility	PDOAllocation	Change Property	Store
STRING	-	-	-	RO	No	-	No
SubIndex 6		Alarm Code 6					
Variable	Setting Range	Default	Unit	Accessi	PDOAllo	Change	Store

Format		Value		bility	cation	Property	
STRING	-	-	-	RO	No	-	No
SubIndex 7		Alarm Code 7					
Variable Format	Setting Range	Default Value	Unit	Accessi bility	PDOAllo cation	Change Property	Store
STRING	-	-	-	RO	No	-	No
SubIndex 8		Alarm Code 8					
Variable Format	Setting Range	Default Value	Unit	Accessi bility	PDOAllo cation	Change Property	Store
STRING	-	-	-	RO	No	-	No
SubIndex 9		Alarm Code 9					
Variable Format	Setting Range	Default Value	Unit	Accessi bility	PDOAllo cation	Change Property	Store
STRING	-	-	-	RO	No	-	No
SubIndex 10		Alarm Code 10					
Variable Format	Setting Range	Default Value	Unit	Accessi bility	PDOAllo cation	Change Property	Store
STRING	-	-	-	RO	No	-	No
SubIndex 11		Alarm Code 11					
Variable Format	Setting Range	Default Value	Unit	Accessi bility	PDOAllo cation	Change Property	Store
STRING	-	-	-	RO	No	-	No
SubIndex 12		Alarm Code 12					
Variable Format	Setting Range	Default Value	Unit	Accessi bility	PDOAllo cation	Change Property	Store
STRING	-	-	-	RO	No	-	No
SubIndex 13		Alarm Code 13					
Variable Format	Setting Range	Default Value	Unit	Accessi bility	PDOAllo cation	Change Property	Store
STRING	-	-	-	RO	No	-	No
SubIndex 14		Alarm Code 14					
Variable Format	Setting Range	Default Value	Unit	Accessi bility	PDOAllo cation	Change Property	Store
STRING	-	-	-	RO	No	-	No
SubIndex 15		Alarm Code 15					
Variable Format	Setting Range	Default Value	Unit	Accessi bility	PDOAllo cation	Change Property	Store
STRING	-	-	-	RO	No	-	No

SubIndex 16		Alarm Code 16(the oldest)					
Variable Format	Setting Range	Default Value	Unit	Accessi bility	PDOAllo cation	Change Property	Store
STRING	-	-	-	RO	No	-	No

Shows up to 16 servo alarms that occurred up to 16. Subindex 1 is the most recent alarm, and the 16 is the oldest alarm. The servo history can be reset through procedure command.

● **Third Party Motor Support(0x2800~)**

We provide you with the following moter parameters to drive third party motors using this drive. Motor can be activated only when the appropriateparameter is iput. Regarding this, this company did not perform any test on combination of this drive and any other third party montor. And we offer no guarantee on the characteristics of such motors.

0x2800	[Third Party Motor] Type						ALL
Variable Format	Setting Range	Default Value	Unit	Accessi bility	PDOAllo cation	Change Property	Store
UINT	0 to 1	0	-	RW	No	Power Resupply	Yes

Sets motor type.

Set Value	Setting Details
0	Rotary motor
1	Linear motor

0x2801	3 rd party [Third Party Motor]Number of Poles						ALL
Variable Format	Setting Range	Default Value	Unit	Accessi bility	PDOAllo cation	Change Property	Store
UINT	2 to 1000	8	-	RW	No	-	Yes

Sets the number of poles. Please set the value to 2 when using a linear motor.

0x2802	[Third Party Motor]Rated Current						ALL
Variable Format	Setting Range	Default Value	Unit	Accessi bility	PDOAllo cation	Change Property	Store
FP32	-	2.89	Arms	RW	No	-	Yes

Sets the motor's rated current.

0x2803	[Third Party Motor]Maximum Current						ALL
Variable Format	Setting Range	Default Value	Unit	Accessi bility	PDOAllo cation	Change Property	Store
FP32	-	8.67	Arms	RW	No	-	Yes

Sets the motor's maximum current.

0x2804	[Third Party Motor]Rated Speed						ALL
Variable	Setting Range	Default	Unit	Accessi	PDOAllo	Change	Store

Format		Value		bility	cation	Property	
UINT	1 to 60000	3000	rpm	RW	No	-	Yes

Sets the motor's rated speed. For linear motors, the unit is mm/s.

0x2805	[Third Party Motor]Maximum Speed						ALL
Variable Format	Setting Range	Default Value	Unit	Accessi bility	PDOAllo cation	Change Property	Store
UINT	1 to 60000	5000	rpm	RW	No	-	Yes

Sets the motor's maximum speed. For linear motors, the unit is mm/s.

0x2806	[Third Party Motor]Inertia						ALL
Variable Format	Setting Range	Default Value	Unit	Accessi bility	PDOAllo cation	Change Property	Store
FP32	-	0.321	Kg.m ² . 10 ⁻⁴	RW	No	-	Yes

Sets the motor's inertia. The weight of the mover should also be set for linear motors. The unit is KG..

0x2807	[Third Party Motor]Torque Constant						ALL
Variable Format	Setting Range	Default Value	Unit	Accessi bility	PDOAllo cation	Change Property	Store
FP32	-	0.46	Nm/A	RW	No	-	Yes

Sets the motor's torqueconstant. The force constant is set for linear motors. The unit is N/A.

0x2808	[Third Party Motor]Phase Resistance						ALL
Variable Format	Setting Range	Default Value	Unit	Accessi bility	PDOAllo cation	Change Property	Store
FP32	-	0.82	ohm	RW	No	-	Yes

Sets the motor's phase resistance (=linear resistance÷2)

0x2809	[Third Party Motor]Phase Inductance						ALL
Variable Format	Setting Range	Default Value	Unit	Accessi bility	PDOAllo cation	Change Property	Store

FP32	0 to 1000	3.66	mH	RW	No	-	Yes
------	-----------	------	----	----	----	---	-----

Sets the motor's phase inductance(=linear inductance ÷2).

0x280A	[Third Party Motor]TN Curve Data 1						ALL
Variable Format	Setting Range	Default Value	Unit	Accessi bility	PDOAllo cation	Change Property	Store
UINT	1 to 60000	3000	rpm	RW	No	-	Yes

Sets the motor's speed/torquecurve data. The maximum speed that outputs the maximum torque (maximum thrust for of linear motor) is input. The unit for linear motor is mm/s.

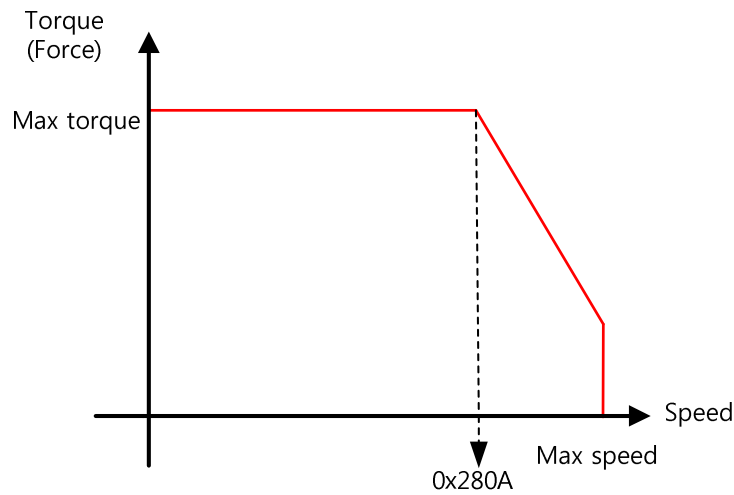

0x280B	[Third Party Motor]TN Curve Data 2						ALL
Variable Format	Setting Range	Default Value	Unit	Accessi bility	PDOAllo cation	Change Property	Store
FP32	-	100.0	%	RW	No	-	Yes

Sets the motor's speed/torque curve data. The torque which can be output at the maximum speed is input in percentage based on the maximum torque.

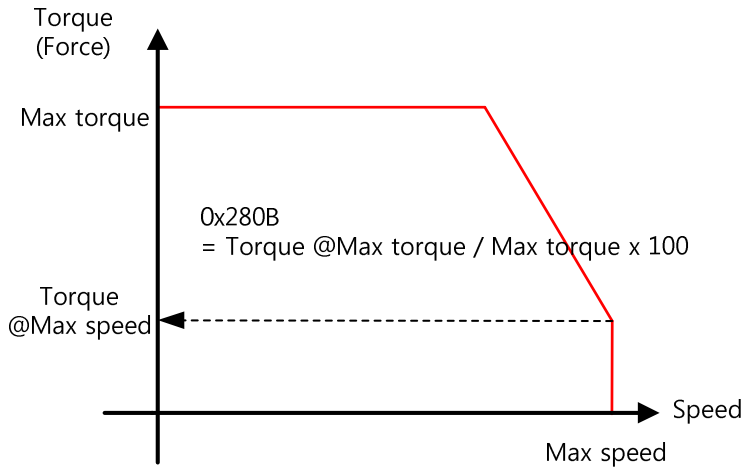

0x280C	[Third Party Motor]Hall Offset						ALL
Variable Format	Setting Range	Default Value	Unit	Accessibility	PDOAllocation	Change Property	Store
UINT	0 to 360	0	deg	RW	No	-	Yes

The hall sensor offset may vary depending on the manufacture. Please check the hall sensor offset before setting.

13.4 Index Objects

0x3000	Control Mode						ALL
Variable Format	Setting Range	Default Value	Unit	Accessibility	communication address	Change Property	Store
UINT	0 to 1	0	-	RW		Servo Off	Yes

Sets the drive's position control mode.

Set Value	Setting Details
0	Index position operation mode
1	Pulse input position operation mode
2	Velocity operation mode
3	Torque operation mode
4	Pulse input position operation mode & Index position operation mode
5	Pulse input position operation mode & Velocity operation mode
6	Pulse input position operation mode & Torque operation mode
7	Velocity operation mode & Torque operation mode
8	Index position operation mode & Velocity operation mode
9	Index position operation mode & Torque operation mode

0x3001	Coordinate Select						ALL
Variable Format	Setting Range	Default Value	Unit	Accessibility	communication address	Change Property	Store
UINT	0 to 1	0	-	RW		Servo Off	Yes

Sets the coordinate to use for the drive's indexing position control

Set Value	Setting Details
0	Use Linear Coordinate
1	Use Rotary Coordinate

0x3002	Baud Rate Select					ALL	
Variable Format	Setting Range	Default Value	Unit	Accessibility	PDOAllocation	Change Property	Store
UINT	0 to 3	0	-	RW	No	Power	Yes

						Resupply	
--	--	--	--	--	--	----------	--

Sets the serial communication speed through RS 422 between the host controller and the drive

Set Value	Setting Details
0	9600 [bps]
1	19200 [bps]
2	38400 [bps]
3	57600 [bps]

0x3003	Pulse Input Logic Select						ALL
Variable Format	Setting Range	Default Value	Unit	Accessibility	PDO Allocation	Change Property	Store
UINT	0 to 5	0	-	RW	No	Servo Off	Yes

Sets the logic of pulse strings from the host controller. The shape of input pulses and rotation direction for each direction are as follows.

Set Value	Setting Details
0	PHASE A+PHASE B Positive Logic
1	CW+CCW Positive Logic
2	Pulse+sign Positive Logic
3	PHASE A+PHASE B Negative Logic
4	CW+CCW Negative Logic
5	Pulse+Sign Negative Logic

0x3004	Pulse Input Filter Select						ALL
Variable Format	Setting Range	Default Value	Unit	Accessibility	PDO Allocation	Change Property	Store
UINT	0 to 4	0	-	RW	No	Servo Off	Yes

Sets the frequency bandwidth of digital filter that is set at the pulse input unit.

The frequency bandwidth are selected according to width of the input pulses 대역은 디지털 필터

Set Value	Setting Details
0	Do not use filter
1	500Khz (Min)
2	750Khz
3	1Mhz (Default)
4	1.25Mhz

0x3005	PCLEAR Mode Select						ALL
Variable	Setting Range	Default	Unit	Accessibility	PDO Allocation	Change	Store

Format	Setting Range	Value	Unit	Accessi- bility	PDOAllo- cation	Change Property	Store
UINT	0 to 2	0	-	RW	No	At all times	Yes

Sets the action mode when inputting positionpulse clear (PCLR)signal.

Set Value	Setting Details
0	Operate at the Edge mode
1	Operate at the :eve;mode(torque: maintain)
2	Operate at the :eve;mode(torque: 0)

Variable Format	Setting Range	Default Value	Unit	Accessi- bility	PDOAllo- cation	Change Property	Store
UDINT	0 to 2147483647	10000	pulse	RW	No	Servo Off	Yes

Sets the number of pulse output per rotation when outputting encoder signal from the drive to outside.

Variable Format	Setting Range	Default Value	Unit	Accessi- bility	PDOAllo- cation	Change Property	Store
UINT	0 to 1	0	-	RW	No	Power Resupply	Yes

Determines whether to use the open collector method other than the line drive method, when outputting encoder signals from the servo

Set Value	Setting Details
0	Line drive Only
1	Line drive+ open collector

Variable Format	Setting Range	Default Value	Unit	Accessi- bility	PDOAllo- cation	Change Property	Store
UINT	0 to 63	0	-	RW	No	At all times	Yes

Sets the number(0~63) to operate when starting indexing position

In the case of the setting value is 64, index number is determined by ISEL0~ISEL5

0x3009	Index Buffer Mode						ALL
Variable Format	Setting Range	Default Value	Unit	Accessibility	PDOAllocation	Change Property	Store
UINT	0 to 1	0	-	RW	No	At all times	Yes

Set how many times memory count START (operation) signals during operating indexing position.

Set Value	Setting Details
0	Double buffer set (it can remember second times)
1	Single buffer set (it can remember one time)

0x3100 ~ 0x313F	Index00 ~ Index63 Index00 ~ Index63						
SubIndex 0		Number of Entries(Number of entries)					
Variable Format	Setting Range	Default Value	Unit	Accessibility	PDOAllocation	Change Property	Store
USINT	-	11	-	RO	No	-	No
SubIndex 1		Index Type					
Variable Format	Setting Range	Default Value	Unit	Accessibility	PDOAllocation	Change Property	Store
UINT	0 to 10	1	-	RW	No	At all times	Yes
SubIndex 2		Distance					
Variable Format	Setting Range	Default Value	Unit	Accessibility	PDOAllocation	Change Property	Store
DINT	-2147483648 to 2147483647	100000	UU	RW	No	At all times	Yes
SubIndex 3		Speed					
Variable Format	Setting Range	Default Value	Unit	Accessibility	PDOAllocation	Change Property	Store
DINT	1 to 2147483647	100000	UU/s	RW	No	At all times	Yes
SubIndex 4		Acceleration					
Variable Format	Setting Range	Default Value	Unit	Accessibility	PDOAllocation	Change Property	Store
DINT	1 to 2147483647	1000000	UU/s ²	RW	No	At all times	Yes
SubIndex 5		Deceleration					
Variable Format	Setting Range	Default Value	Unit	Accessibility	PDOAllocation	Change Property	Store
DINT	1 to 2147483647	1000000	UU/s ²	RW	No	At all times	Yes
SubIndex 6		Registration Distance					
Variable Format	Setting Range	Default Value	Unit	Accessibility	PDOAllocation	Change Property	Store

DINT	-2147483648 to 2147483647	100000	UU	RW	No	At all times	Yes
SubIndex 7		Registration Speed					
Variable Format	Setting Range	Default Value	Unit	Accessibility	PDOAllocation	Change Property	Store
DINT	1 to 2147483647	1000000	UU/s	RW	No	At all times	Yes
SubIndex 8		Repeat Count					
Variable Format	Setting Range	Default Value	Unit	Accessibility	PDOAllocation	Change Property	Store
UINT	1 to 65535	1	-	RW	No	At all times	Yes
SubIndex 9		Dwell Time					
Variable Format	Setting Range	Default Value	Unit	Accessibility	PDOAllocation	Change Property	Store
UINT	0 to 65535	200	ms	RW	No	At all times	Yes
SubIndex 10		Next Index					
Variable Format	Setting Range	Default Value	Unit	Accessibility	PDOAllocation	Change Property	Store
UINT	0 to 63	1	-	RW	No	At all times	Yes
SubIndex 11		Index Action					
Variable Format	Setting Range	Default Value	Unit	Accessibility	PDOAllocation	Change Property	Store
UINT	0 to 2	2	-	RW	No	At all times	Yes

13.5 CiA402 Objects

0x603F	Error Code						ALL
Variable Format	Setting Range	Default Value	Unit	Accessibility	PDOAllocation	Change Property	Store
UINT	-	0	-	RO	Yes	-	No

Shows the alarm code that set off the last time at the servo driver.

0x605A	Quick Stop Option Code						ALL
Variable Format	Setting Range	Default Value	Unit	Accessibility	PDOAllocation	Change Property	Store
INT	0 to 4	2	-	RW	No	At all times	Yes

Sets Quick Stop option codes.

Set Value	Descriptions
0	Do not use (transit into Switch On Disabled).
1	Slowly decelerates then stop, depending on the quick stop deceleration (0x6085) setting. (Switch On Disabled)
2	Slowly decelerates then stop, depending on the quick stop deceleration (0x6085) setting. (Switch On Disabled) (Switch On Disabled)
3	Stops at the torque limit (Switch On Disabled)

0x605B	Shutdown Option Code						ALL
Variable Format	Setting Range	Default Value	Unit	Accessibility	PDOAllocation	Change Property	Store
INT	0 to 1	0	-	RW	No	At all times	Yes

Sets the actions for servo drive shutdown(Operation Enable state ->Ready to Switch On state)

Set Value	Descriptions
0	Do not use
1	Deceleration and stop, Switch On Disabled and stop, Ready status

0x605C	Disable Operation Option Code						ALL
Variable Format	Setting Range	Default Value	Unit	Accessibility	PDOAllocation	Change Property	Store
INT	0 to 1	1	-	RW	No	At all times	Yes

Sets the option code for disable operation status (Operation Enable state → Switched On state).

Set Value	Descriptions
0	Do not use drive function
1	Deceleration and stop, movement with the Switch On Disable, not ready..

0x605D	Halt Option Code						ALL
Variable Format	Setting Range	Default Value	Unit	Accessibility	PDOAllocation	Change Property	Store
INT	0 to 4	0	-	RW	No	At all times	Yes

Halt option code sets the movement method when moving from operation enable state to switched on state.

Set Value	Descriptions
1	Deceleration and stop, Operation Enabled
2	Deceleration and stop with quick stop deceleration, Operation Enabled
3	Deceleration and stopwith torque limittorque, Operation Enabled

0x605E	Fault Reaction Option Code						ALL
Variable Format	Setting Range	Default Value	Unit	Accessibility	PDOAllocation	Change Property	Store
INT	0	0	-	RW	No	At all times	Yes

Sets the action method for fault action to protect the drive's system.

Set Value	Descriptions
0	Do not use servo drive functions. Keep the motor at free run.

0x6060	Modes of Operation						ALL
Variable Format	Setting Range	Default Value	Unit	Accessibility	PDOAllocation	Change Property	Store
SINT	-1 to 10	0	-	RW	Yes	At all times	No

Sets the operation mode for the servo drive. After turning the power on, the driver the master determines the operation mode.

The drive provides the following operation modes.

Set Value	Namd	Description
-1	IP	Indexing Position / Pulse Input Position
0	-	No mode allocation
1	-	Reserved
2	-	Reserved
3	-	Reserved
4	-	Reserved
6	HM	Homing mode
7	-	Reserved
8	-	Reserved
9	-	Reserved
10	-	Reserved
Other	-	Reserved

0x6061		Modes of Operation Display					ALL
Variable Format	Setting Range	Default Value	Unit	Accessi bility	PDOAllo cation	Change Property	Store
SINT	-	-	-	RO	Yes	-	No

Sets the operation mode of the drive

0x6062		Position Demand Value					ALL
Variable Format	Setting Range	Default Value	Unit	Accessi bility	PDOAllo cation	Change Property	Store
DINT	-	-	UU	RO	Yes	-	No

Shows the position demanded by the user as positionUnit(UU).

0x6063		Position Actual Internal Value					ALL
Variable Format	Setting Range	Default Value	Unit	Accessi bility	PDOAllo cation	Change Property	Store
DINT	-	-	pulse	RO	Yes	-	No

Shows the actual internal position of the encoder, by pulse.

0x6064		Position Actual Value					ALL
Variable Format	Setting Range	Default Value	Unit	Accessi bility	PDOAllo cation	Change Property	Store

DINT	-	-	UU	RO	Yes	-	No
------	---	---	----	----	-----	---	----

Shows the actual position value of the encoder, by pulse

0x6065	Following Error Window						ALL
Variable Format	Setting Range	Default Value	Unit	Accessibility	PDOAllocation	Change Property	Store
UDINT	0 to 0x3FFFFFFF	600000	UU	RW	No	At all times	Yes

Sets the position error range to check following error (Statusword, 0x6041.13)

Set proper value and encoder resolution of motor before motor drives.

For example) If the value of encoder pulse [0x2002] is 12000 and the range of error position is 3 rotations of motor, set 36000.

0x6066	Following Error Timeout						ALL
Variable Format	Setting Range	Default Value	Unit	Accessibility	PDOAllocation	Change Property	Store
UINT	0 to 65535	0	ms	RW	No	At all times	Yes

Sets the over time for checking the following error (Statusword, 0x6041.13).

0x6067	Position Window						ALL
Variable Format	Setting Range	Default Value	Unit	Accessibility	PDOAllocation	Change Property	Store
UDINT	0 to 0x3FFFFFFF	100	UU	RW	No	At all times	Yes

Sets the position window to the target. Holding within the position window for the duration of position window time, set the statusword's Bit10 (0x6041.10) to 1.

0x6068	Position Window Time						ALL
Variable Format	Setting Range	Default Value	Unit	Accessibility	PDOAllocation	Change Property	Store
UINT	0 to 65535	0	ms	RW	No	At all times	Yes

Sets the position window to the target. Holding within the position window for the duration of position window time, set the statusword's Bit10 (0x6041.10) to 1.

0x606B	Speed Demand Value						ALL
--------	--------------------	--	--	--	--	--	-----

Variable Format	Setting Range	Default Value	Unit	Accessibility	PDOAllocation	Change Property	Store
DINT	-	-	UU/s	RO	Yes	-	No

Shows the output speed of the controller or command speed input into the speed controller.

0x606C	Speed Actual Value						ALL
Variable Format	Setting Range	Default Value	Unit	Accessibility	PDOAllocation	Change Property	Store
DINT	-	-	UU/s	RO	Yes	-	No

Shows the actual speed value of the position unit defined by the user.

0x606D	Speed Window						ALL
Variable Format	Setting Range	Default Value	Unit	Accessibility	PDOAllocation	Change Property	Store
UINT	0 to 65535	20000	UU/s	RW	No	At all times	Yes

Sets the speedwindow. If the error between the targetspeed and the actualspeed holds within the speed window(0x606D) for the duration of the speed window time(0x606E), set the statusword's Bit10(0x6041.10) to 1.

0x606E	Speed Window Time						ALL
Variable Format	Setting Range	Default Value	Unit	Accessibility	PDOAllocation	Change Property	Store
UINT	0 to 65535	0	ms	RW	No	At all times	Yes

Sets the speedwindow time. If the error between the targetspeed and the actualspeed holds within the speed window (0x606D) for the duration of the speed window time(0x606E), set the statusword's Bit10(0x6041.10) to 1.

0x6071	Target Torque						ALL
Variable Format	Setting Range	Default Value	Unit	Accessibility	PDOAllocation	Change Property	Store
INT	-5000 to 5000	0	0.1%	RW	Yes	At all times	No

Sets the target torque for torquecontrol by 0.1% of the rated motor torque.

0x6072	Maximum Torque						ALL
--------	----------------	--	--	--	--	--	-----

Variable Format	Setting Range	Default Value	Unit	Accessibility	PDOAllocation	Change Property	Store
UINT	0 to 5000	3000	0.1%	RW	Yes	At all times	No

Sets the maximum torque by 0.1% of the rated motor torque.

0x6074	Torque Demand Value						ALL
Variable Format	Setting Range	Default Value	Unit	Accessibility	PDOAllocation	Change Property	Store
INT	-	-	0.1%	RO	Yes	-	No

Sets the torque currently demanded by 0.1% of the rated motor torque.

0x6077	Torque Actual Value						ALL
Variable Format	Setting Range	Default Value	Unit	Accessibility	PDOAllocation	Change Property	Store
INT	-	-	0.1%	RO	Yes	-	No

Shows the actual torque generated within the drive by 0.1% of the rated motor torque.

0x607C	Home Offset						ALL
Variable Format	Setting Range	Default Value	Unit	Accessibility	PDOAllocation	Change Property	Store
DINT	-536870912 to 536870911	0	UU	RW	No	At all times	Yes

Sets the offset between the absolute encoder or absolute external scale origin and the 0 position of the actual position (Position actual value, 0x6064).

- Incremental Encoder

If the home position was found or the current position is the home position, the 0 point is the position moved from the home position to the target position as much as the home offset..

- Absolute Encoder

When an absolute encoder is added, the home offset value is added to the absolute position (actual position) values.

0x607D	Software Position Limit						
SubIndex 0			Number of entries				
Variable Format	Setting Range	Default Value	Unit	Accessibility	PDOAllocation	Change Property	Store

USINT	-	2	-	RO	No	-	No
SubIndex 1		Min position limit					
Variable Format	Setting Range	Default Value	Unit	Accessibility	PDOAllocation	Change Property	Store
DINT	-1073741824 to 1073741823	-2000000000	UU	RW	No	At all times	Yes
SubIndex 2		Max position limit					
Variable Format	Setting Range	Default Value	Unit	Accessibility	PDOAllocation	Change Property	Store
DINT	-1073741824 to 1073741823	2000000000	UU	RW	No	At all times	Yes

Sets the software position limit value. The range of position demand value (0x6062) and the position actual value (0x6064) are limited, and new target position for the set value is checked every cycle.

The minimum software limit value is negative limit value, and the maximum software limit value is positive limit value.

0x6085	Quick Stop Deceleration						ALL
Variable Format	Setting Range	Default Value	Unit	Accessibility	PDOAllocation	Change Property	Store
UDINT	0 to 0x7FFFFFFF	2000	UU/s ²	RW	No	At all times	Yes

Sets deceleration used for quick stop when the Quick stop option code (0x605A) is set to 2.

0x6091	Gear Ratio						
SubIndex 0		Number of entries					
Variable Format	Setting Range	Default Value	Unit	Accessibility	PDOAllocation	Change Property	Store
USINT	-	2	-	RO	No	-	No
SubIndex 1		Motor revolutions					
Variable Format	Setting Range	Default Value	Unit	Accessibility	PDOAllocation	Change Property	Store
UDINT	0 to 0x40000000	1	-	RW	No	Power Resupply	Yes
SubIndex 2		Shaft revolutions					
Variable Format	Setting Range	Default Value	Unit	Accessibility	PDOAllocation	Change Property	Store
UDINT	0 to 0x40000000	1	-	RW	No	Power Resupply	Yes

See 『7.3 Electronic Gear Setting』 for further details

0x6098	Homing Method						ALL
Variable Format	Setting Range	Default Value	Unit	Accessibility	PDOAllocation	Change Property	Store
SINT	-128 to 127	34	-	RW	No	At all times	Yes

Sets homing method. See 『6.1 Homing』 for further details.

Set Value	Descriptions
0	Do not use homing
1	Homing using indexpulse and negative limit contact
2	Homing using indexpulse and positive limit contact
7 to 14	Homing using indexpulse and home limit contact
24	Same as 8 (does not use index pulse)
28	Same as 12 (does not use index pulse)
33, 34	Homing with index pulse
35	Homing with current position
-1	Homing using negative stopper and indexpulse
-2	Homing using positive stopper and indexpulse
-3	Homing using only negative stopper
-4	Homing using only positive stopper

0x6099		Homing Speeds						
SubIndex 0		Number of entries						
Variable Format	Setting Range	Default Value	Unit	Accessibility	PDOAllocation	Change Property	Store	
USINT	-	2	-	RO	No	-	No	
SubIndex 1		Speed during search for switch						
Variable Format	Setting Range	Default Value	Unit	Accessibility	PDOAllocation	Change Property	Store	
DINT	0 to 0x40000000	500000	UU/s	RW	No	At all times	Yes	
SubIndex 2		Speed during search for zero						
Variable Format	Setting Range	Default Value	Unit	Accessibility	PDOAllocation	Change Property	Store	
DINT	0 to 0x40000000	100000	UU/s	RW	No	At all times	Yes	

Sets the operation speed for homing

0x609A		Homing Acceleration					ALL
Variable Format	Setting Range	Default Value	Unit	Accessibility	PDOAllocation	Change Property	Store
UDINT	0 to 0x40000000	200000	UU/s ²	RW	No	At all times	Yes

Sets operation acceleration for homing.

0x60B1		Speed Offset					ALL
Variable Format	Setting Range	Default Value	Unit	Accessibility	PDOAllocation	Change Property	Store

DINT	-2147483648 to 2147483647	0	UU/s	RW	Yes	At all times	No
------	------------------------------	---	------	----	-----	--------------	----

Corresponds to speed feed forward value for positioncontrol

0x60B2	Torque Offset						ALL
Variable Format	Setting Range	Default Value	Unit	Accessi- bility	PDOAllo- cation	Change Property	Store
INT	-5000 to 5000	0	0.1%	RW	Yes	At all times	No

Corresponds to torque feed forward value for positioncontrol

0x60B8	Touch Probe Function						ALL
Variable Format	Setting Range	Default Value	Unit	Accessi- bility	PDOAllo- cation	Change Property	Store
UINT	0 to 0xFFFF	0x0033	-	RW	Yes	At all times	Yes

Sets touch probe functions

bit	값	Descriptions
0	0	Do not use touch probe 1
	1	Use touch probe 1
1	0	Single triggermode
	1	Continous triggermode
2	0	Trigger by touch probe 1 input
	1	Trigger by index pulsesignal
3	-	Reserved
4	0	Do not capture positive edge position value of touch probe 1
	1	Capture positive edge position value of touch probe 1
5	0	Do not capture negative edge position value of touch probe 1
	1	Capture negative edge position value of touch probe 1
6 to 7	-	Reserved
8	0	Do not use touch probe 2
	1	Use touch probe 2
9	0	Single triggermode
	1	Continous triggermode
10	0	Trigger by touch probe 2 input
	1	Trigger by index pulsesignal
11	-	Reserved
12	0	Do not capture positive edge position value of touch probe 2
	1	Capture positive edge position value of touch probe 2
13	0	Do not capture negative edge position value of touch probe 2

	1	Capture negative edge position value of touch probe 2
14 to 15	–	Reserved

0x60B9	Touch Probe Status						ALL
Variable Format	Setting Range	Default Value	Unit	Accessibility	PDOAllocation	Change Property	Store
UINT	-	-	-	RO	Yes	-	No

Shows touch probe status.

Bit	Value	Descriptions
0	0	Do not use touch probe 1
	1	Use touch probe 1
1	0	Positive edge position value of touch probe 1 is not stored
	1	Positive edge position value of touch probe 1 is stored
2	0	Negative edge position value of touch probe 1 is not stored
	1	Negative edge position value of touch probe 1 is stored
3 to 5	–	Reserved
6	0, 1	Toggled when positive edge position value of touch probe 1 is updated
7	0, 1	Toggled when negative edge position value of touch probe 1 is updated
8	0	Do not use touch probe 2
	1	Use touch probe 2
9	0	Positive edge position value of touch probe 2 is not stored
	1	Positive edge position value of touch probe 2 is stored
10	0	Negative edge position value of touch probe 2 is not stored
	1	Negative edge position value of touch probe 2 is stored
11 to 13	–	Reserved
14	0, 1	Toggled when positive edge position value of touch probe 2 is updated
15	0, 1	Toggled when negative edge position value of touch probe 2 is updated

In continuous trigger mode, bits 6,7,14,15(store all values for touch probe positive/negative edge)are toggled.

To disable bits 1,2,9,10 of touch probe status(0x60B9)(store position values for positive/negative edge of touch probe 1, 2), first disable bits 4,5,12,13 (use sampling values for positive/negative edge of touch probe 1, 2) and then toggle Enable.

0x60BA	Touch Probe 1 Positive Edge Position Value						ALL
Variable Format	Setting Range	Default Value	Unit	Accessibility	PDOAllocation	Change Property	Store
DINT	-	-	UU	RO	Yes	-	No

Shows positive edge position value of touch probe 1.

0x60BB	Touch Probe 1 Negative Edge Position Value						ALL
Variable Format	Setting Range	Default Value	Unit	Accessibility	PDOAllocation	Change Property	Store
DINT	-	-	UU	RO	Yes	-	No

Shows negative edge value of touch probe 1.

0x60BC	Touch Probe 2 Positive Edge Position Value						ALL
Variable Format	Setting Range	Default Value	Unit	Accessibility	PDOAllocation	Change Property	Store
DINT	-	-	UU	RO	Yes	-	No

Shows positive edge value of touch probe 2.

0x60BD	Touch Probe 2 Negative Edge Position Value						ALL
Variable Format	Setting Range	Default Value	Unit	Accessibility	PDOAllocation	Change Property	Store
DINT	-	-	UU	RO	Yes	-	No

Shows negative edge value of touch probe 2.

0x60E0	Positive Torque Limit Value						ALL
Variable Format	Setting Range	Default Value	Unit	Accessibility	PDOAllocation	Change Property	Store
UINT	0 to 5000	3000	0.1%	RW	Yes	At all times	Yes

Sets the positive torque limit value.

0x60E1	Negative Torque Limit Value						ALL
Variable Format	Setting Range	Default Value	Unit	Accessibility	PDOAllocation	Change Property	Store
UINT	0 to 5000	3000	0.1%	RW	Yes	At all times	Yes

Sets the negative torque limit value.

0x60F4	Following Error Actual Value						ALL
Variable	Setting Range	Default Value	Unit	Accessibility	PDOAllocation	Change	Store

Format				bility	cation	Property	
DINT	-	-	UU	RO	Yes	-	No

Shows the following error actual value for position control

0x60FC	Position Demand Internal Value						ALL
Variable Format	Setting Range	Default Value	Unit	Accessi bility	PDOAllo cation	Change Property	Store
DINT	-	-	pulse	RO	Yes	-	No

Shows the command input value for positioncontrol.

0x60FD	Digital Inputs						ALL
Variable Format	Setting Range	Default Value	Unit	Accessi bility	PDOAllo cation	Change Property	Store
UDINT	-	-	-	RO	Yes	-	No

Shows digital input status

bit	Descriptions
0	NOT(negative limit switch)
1	POT(positive limit switch)
2	HOME(origin sensor input)
3 to 15	Reserved
16	DI #1(I/O pin 12), 0:Open, 1:Close
17	DI #2(I/O pin 13), 0:Open, 1:Close
18	DI #3(I/O pin 14), 0:Open, 1:Close
19	DI #4(I/O pin 15), 0:Open, 1:Close
20	DI #5(I/O pin 16), 0:Open, 1:Close
21	DI #6(I/O pin 17), 0:Open, 1:Close
22	DI #7(I/O pin 18), 0:Open, 1:Close
23	DI #8(I/O pin 19), 0:Open, 1:Close
16	DI #9(I/O pin 22), 0:Open, 1:Close
17	DI #10(I/O pin 23), 0:Open, 1:Close
18	DI #11(I/O pin 24), 0:Open, 1:Close
19	DI #12(I/O pin 25), 0:Open, 1:Close
20	DI #13(I/O pin 26), 0:Open, 1:Close
21	DI #14(I/O pin 27), 0:Open, 1:Close
22	DI #15(I/O pin 28), 0:Open, 1:Close
23	DI #16(I/O pin 29), 0:Open, 1:Close
24~30	Reserved
31	Reserved

0x60FE		Digital Outputs					
SubIndex 0		Number of entries					
Variable Format	Setting Range	Default Value	Unit	Accessibil ity	PDOAllocati on	Change Property	Store
USINT	-	2	-	RO	No	-	No
SubIndex 1		Physical outputs					
Variable Format	Setting Range	Default Value	Unit	Accessibil ity	PDOAllocati on	Change Property	Store
UDINT	0 to 0xFFFFFFFF	0	-	RW	Yes	At all times	No
SubIndex 2		Bit mask					
Variable Format	Setting Range	Default Value	Unit	Accessibil ity	PDOAllocati on	Change Property	Store
UDINT	0 to 0xFFFFFFFF	0	-	RW	Yes	At all times	Yes

Shows digital output status

- Physical outputs descriptions

bit	Descriptions
0 to 15	Reserved
16	Forced output of DO#1(I/Opin 35, 36) (0:OFF, 1:ON) Provided that the relevant bit mask (0x60FE:02.16) is set to 1
17	Forced output of DO#1(I/Opin 37, 38) (0:OFF, 1:ON) Provided that the relevant bit mask (0x60FE:02.17) is set to 1
18	Forced output of DO#1(I/Opin 39, 40) (0:OFF, 1:ON) Provided that the relevant bit mask (0x60FE:02.18) is set to 1
19	Forced output of DO#1(I/Opin 41, 42) (0:OFF, 1:ON) Provided that the relevant bit mask (0x60FE:02.19) is set to 1
20	Forced output of DO#1(I/Opin 43, 44) (0:OFF, 1:ON) Provided that the relevant bit mask (0x60FE:02.20) is set to 1
21	Forced output of DO#1(I/Opin 45, 46) (0:OFF, 1:ON) Provided that the relevant bit mask (0x60FE:02.21) is set to 1
22	Forced output of DO#1(I/Opin 47, 48) (0:OFF, 1:ON) Provided that the relevant bit mask (0x60FE:02.22) is set to 1
23	Forced output of DO#1(I/Opin 49, 50) (0:OFF, 1:ON) Provided that the relevant bit mask (0x60FE:02.23) is set to 1
24	DO #1output status (0:OFF, 1:ON)
25	DO #2output status (0:OFF, 1:ON)
26	DO #3 output status (0:OFF, 1:ON)
27	DO #4output status (0:OFF, 1:ON)
28	DO #5output status (0:OFF, 1:ON)
29	DO #6output status (0:OFF, 1:ON)
30	DO #7output status (0:OFF, 1:ON)

31	DO #8output status (0:OFF, 1:ON)
----	----------------------------------

▪ Bit maskDescriptions

bit	Descriptions
0 to 15	Reserved
16	DO#1(I/O pin 35, 36) output status setting (0:Disable, 1:Enable)
17	DO#2(I/O pin 37, 38) output status setting (0:Disable, 1:Enable)
18	DO #3(I/O pin 39, 40)output status setting (0:Disable, 1:Enable)
19	DO #4(I/O pin 41, 42)output status setting (0:Disable, 1:Enable)
20	DO#1(I/O pin 43, 44) output status setting (0:Disable, 1:Enable)
21	DO#2(I/O pin 45, 46) output status setting (0:Disable, 1:Enable)
22	DO #3(I/O pin 47, 48)output status setting (0:Disable, 1:Enable)
23	DO #4(I/O pin 49, 50)output status setting (0:Disable, 1:Enable)
24 to 31	Reserved

0x60FF	Target Speed						ALL
Variable Format	Setting Range	Default Value	Unit	Accessibility	PDOAllocation	Change Property	Store
DINT	-2147483648 to 2147483647	0	UU/s	RW	Yes	At all times	No

Sets the target speed at PV modeand CSV mode.

0x6502	Supported Drive Modes						ALL
Variable Format	Setting Range	Default Value	Unit	Accessibility	PDOAllocation	Change Property	Store
UDINT	-	0x000003AD	-	RO	No	-	No

Shows the modes supported by the drive

bit	Supported Modes	Description
-1	IP (Indexing Position/Pulse Input Position)	1: Supported
0	PP (Profile Position)	0: Not supported
1	VI (Speed)	0: Not supported
2	PV (Profile Speed)	0: Not supported
3	PT (Torque Profile)	0: Not supported
4	Reserved	0
5	HM (Homing)	1: Supported
6	IP (Interpolated Position)	0: Not Supported
7	CSP (Cyclic Synchronous Position)	0: Not supported
8	CSV (Cyclic Synchronous Speed)	0: Not supported

9	CST (Cyclic Synchronous Torque)	0: Not supported
10 to 31	Reserved	0





14. Maintenance and Checkup

14.1 Abnormality Diagnosis and Actions

Abnormality during operation sets off alarm or warning. In such cases, please check the corresponding code and take appropriate actions. When the abnormality is not corrected after such actions, please contact us at our service department.

14.2 Servo Alarm

Upon detecting abnormality, the drive sets off the servo alarm, and transitions to servo off status and stops. In such case, the stop method follows the set value of the emergency stop setting (0x2013).

Alarm Code Name	Causes	Checklist	Trouble shooting
 IPM fault (Overcurrent(H/W))  Over current (Overcurrent(S/W))  Current limit exceeded (Overcurrent(H/W))	Motor cable error	Wiring is incorrect and check short	Replace motor cable
	Encoder cable error	Wiring is incorrect and check short	Replace encoder cable
	Parameter cable error	Motor ID [0x2000], encoder type[0x2001], encoder form[0x2002] setting value should be same with applied to motor label.	Modify motor label and parameter concordantly
	Check motor phase resistor	Check if U/V/W phase current offset(0x2015~0x2017) is 5% or above of the rated current, Replace drive	Replace motor
		Determine whether there is a conflict or binding in the equipment.	
	Drive error		
	Error by noise	Check method to improve noise of wiring, install.	Please check condition of wiring for FG. Match wire size of FG with wire size of drive main circuit.
 Regeneration overload IPM temperature	surroundings temperature	Check whether surrounding temperature is over 50 [°C]	Lower surrounding temperature
	Continuous Overload alarm	Accumulated operate overload percentage [0x2603] Checking the load percentage is under 100%	Change drive and motor capacity,
	Motor cable open	Check accumulated regenerative overload[0x2606]	Adjust regeneration resistor setting[0x2009] Use external regeneration resistor.
	Drive setting direction	Check drive setting status	Refer "2. Wiring and Joint
	Drive error		
 Current offset	Motor U/V/W phase current offset oversetting	Check whether the U/V/W phase current offset [0x2015~0x2017] are 5% of the rated current or higher.	Rerun adjusting phase current offset

Alarm Code Name	Causes	Checklist	Troble shooting
	Drive error		If alarm occurs continually after adjusting offset of phase current, please replace new drive because drive has problem.
 Continuous overload	In case of sequent operating that exceed rated load	Check if load which is accumulating driving load rate[0x2603] is below 100% when it is in constant speed section and stop	Change drive and motor capacity. Please tune gains
	Motor brake error	Check set value, encoder wiring	Provide power to motor brake
	Parameter setting error	Check encoder wiring, replace encoder	Modify the parameter as same as motor label information.
		Check encoder wiring, replace encoder	Set as proper value
	Machine has problem	there is no problem for running	Check machine part.
	Motor cable error	Wiring is incorrect and check short	Replace motor cable.
	Encoder cable error	Wiring is incorrect and check short	Replace encoer cable.
 Drive temperature 1	surrounding temerature	Check whether surrounding temperature is over 50 [°C]	Lower surrounding temperature of drive
	Drive error	Check if displayed value 1 [0x260B] of drive temperature is much different with surrounding temperature when it is normal condition.	Replace the drive
 Regeneration overload	Capacity excess by high frequency operating or Continue regenerative operating	Check encoder abnormality, encoder set value, encoder wiring, gain setting, motor wiring, motor ID, electronic gear ratio, speedcommand scale	Adjust value on 0x2009. Use braking resistor
	Parameter setting error	Check positionerrorange (0x6065) andpositionerrorexcess time (0x6066) Set Value, wiring and limit contact, gainset value, ecoder setting, electronic gear ratop setting. Check for equipment arrest and load status.	Set as proper value
	Emergency stop	Check emergency stop input.	Recheck the power supply
	Drive error	Check excessive speed error alarm detection level (0x2310), wiring and limit contact, gainset value, encoder setting, electronic gear ratio setting. Check for equipment arrest and load status.	Replace the drive
 Motor cable open	Motor cable error	Check whether cable is disconnected.	Replace motor cable
	Motor error	Check short circuit of U,V,W in Motor (U-V, V-W, W-U)	Replace motor
	Drive error		If specific alarm signal is persistently occurred, It is highly possible to have fault, so Kindly recommend you to change the servo drive.

Alarm Code Name	Causes	Checklist	Troble shooting
AL-25 Drive temperature 2	Surrounding temperature	Check whether surrounding temperature is over 50[°C]	Lower the surrounding temperature of drive
	Drive error	Comparing displayed drive temperature 2 [0x260C] in normal status and the surrounding temperature.	Replace the drive
AL-26 Encoder temperature	Reserved		
AL-30 Encoder communication AL-31 Encoder cable open AL-32 Encoder data	Encoder cable error	Disconnect, wiring is incorrect and check Short.	Replace encoder cable.
	Parameter setting error	Value of [0x2001], [0x2002] is same with application motor label.	Modify the parameter as same as motor label information. If modified value is not applied to parameter, it is highly possible to have fault, So Kindly recommend you to change the servo motor.
	Encoder error		If alarm continue after servo on again, Replace drive. Because drive may have problem.
AL-33 Motor setting	Setting Motor ID	Value of [0x2000] is same with application motor label.	Revise it with motor label information equally. It is possible to release alarm when power off/on after adjusting parameter.
AL-34 Encoder setting	Wiring is incorrect and check Short.	Wiring is incorrect and check Short.	Replace encoder cable.
	Encoder error		If alarm continue after servo on again, Replace drive. Because drive may have problem.
	Drive error		If alarm continue after servo on again, Replace drive. Because drive may have problem.
AL-35 Low battery	Parameter setting error	Check setting value [0x2005]	Revise it with motor label information equally. It is possible to release alarm when power off/on after adjusting parameter.
	Bad connection of battery No connected.	Check status of battery access	Connect battery rightly.
	When battery voltage is low	Check whether voltage is over 3.3V	Replace battery
AL-36 Sinusoidal ENC	Encoder cable error	Wiring is incorrect and check short Check shield and FG disconnect	Replace encoder cable.

Alarm Code Name	Causes	Checklist	Troble shooting
amplitude AL-37 Sinusoidal ENC frequency	Parameter setting error	Check setting valud of encoder type [0x2001]	Check setting encoder type.
	Drive error		If alarm continue after servo on again, Replace drive. Because drive may have problem.
	resolver error		If alarm continue after servo on again, Replace drive. Because drive may have problem.
AL-38 Z phase open	Drive / Motor combination error	Check brand label code of motor and drive.	Use motor and drive of same brand label.
	Encoder cable error	Wiring is incorrect and check Short	Replace encoder cable.
	Encoder error		If alarm continue after servo on again, Replace drive. Because drive may have problem.
	Drive error		If alarm continue after servo on again, Replace drive. Because drive may have problem.
AL-40 Under voltage	Main power input voltage error	Check the main power voltage is over 3phase 134[Vac]	Recheck the power supply.
		Check DC link value [0x2605] is over 190[Vdc] when main power is accordingly input	
	running when power voltage is low	Check wiring of main power supply	Use 3 phase as supply voltage.
AL-41 Over voltage	Main power input voltage error	Check whether the main power voltage is below 253[Vac]	Recheck the power supply.
		Check DC link value [0x2605] is below 405[V] when main power is accordingly input	Replace the drive.
	When braking resistor is high	Check operating condition regenerative resistance.	Review the regenerative resistance consider the operating condition and load.
	Setting value of acceleration/ deceleration	In case of many time for acceleration/ deceleration	Set longer acceleration/ deceleration time
	Drive error		If alarm continue after servo on again, Replace drive. Because drive may have problem.
AL-42 Main power fail	Main power input voltage error	check voltage between phase 200-230[Vac] of L1, L2, L3	Recheck power supply.
	Parameter setting error	Check setting value arrodng to state of main power [0x2006]	Wire or set parameter as input power on (possible 3 phase)
	momentary power failure	Check setting value [0x2007]	Check main power source or reduce value of [0x2007]







Alarm Code Name	Causes	Checklist	Troble shooting	
	Drive error		If alarm continue after servo on again, Replace drive. Because drive may have problem.	
AL-43 Control power fail	Voltage between phase of C1, C2 error	Voltage between phase of C1, C2 is within 200-230[Vac].	Recheck power supply of drive	
	Drive error		If alarm continue after servo on again, Replace drive. Because drive may have problem.	
AL-50 Over speed limit	Motor Encoder error	Wiring is incorrect and check Short.	Replace motor cable.	
	Encoder cable error	Wiring is incorrect and check Short.	Replace encoder cable.	
	Parameter setting error	Value of [0x2000], [0x2001], [0x2002] is same with application motor label.		Modify the parameter as sams as motor label information.
		Check setting value [0x6091]		Set Electronic gear ratio low.
		Check setting value[0x2100] ~ [0x211F]		Readjust gain according to operating condtion.
	Encoder error		If alarm continue after servo on again, Replace drive. Because drive may have problem.	
Drive error		If alarm continue after servo on again, Replace drive. Because drive may have problem.		
AL-51 POS following	Parameter setting error	Check setting value [0x3000], [0x3003], [0x3004].	Set up correct parameter according to operating method.	
		Check [0x6091] Setting value	Set Electronic gear ratio low.	
		Check setting value on 0x6066 of position error excess time, 0x6065 of position error range	Set up correct parameter according to operating method.	
	Machine part has problem	Checking it was forced by drive part	Check Machine part has problem	
	Drive error		If alarm continue after servo on again, Replace drive. Because drive may have problem.	
AL-53 Excessive SPD deviation	Motor cable error	Disconnect, wiring is incorrect and check Short.	Replace motor cable	
	Encoder cable error	Disconnect, wiring is incorrect and check Short.	Replace encoder cable	
	Parameter setting	Value of [0x2000], [0x2001], [0x2002] is same with application motor label.		Modify the parameter as sams as motor label information.
		Check setting value [0x6091]		Set Electronic gear ratio low..
	Machine part has problem	Checking it was forced by drive part operating condition of limit contact point sensor	Check Machine part.	
	Encoder error		If alarm continue after servo on again, Replace drive. Because drive may have problem.	
AL-54 Encoder2 POS difference	Reserved			

Alarm Code Name	Causes	Checklist	Troble shooting
AL-60 USB communication	Reserved		
AL-61 reserved	Reserved		
AL-62 reserved	Reserved		
AL-63 Parameter checksum	When O/S is changed	Check parameter that parameter setting value was set as maximum value of variable form	Restore initial parameter (0x1011). If you restore it, setting up parameter would be changed into initial value. So set up parameter before operating
	Drive error		If alarm continue after servo on again, Replace drive. Because drive may have problem.
AL-64 Parameter range	Reserved		
AL-70 Drive motor combination	Reserved		
AL-71 Factory setting	Drive error	Contact customer service	If alarm occurs continuously after reinputing power, replace the drive due to possibility of fault of drive.
AL-72 GPIO setting	Reserved		

14.3 Servo Warning

Upon detecting abnormality corresponding to servo warning, the drive sets off the relevant warning. In such case, the drive maintains normal operation. Warning is automatically cleared when the cause is removed. Upon warning, please take appropriate actions. You can set whether each warning is checked through warning mask setting (0x2014).

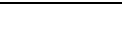
bit	Warning Code	WarningName
0	W01	Main power fail
1	W02	Low encoder battery
2	W04	Software positionlimit
3	W08	Excessive DB current
4	W10	Operation overload
5	W20	Driver/motor combination fail
6	W40	Low voltage
7	W80	Emergency signalinput

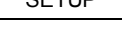
Warning Status(CODE) Name	Description and Cause	Checklist
 PWR_FAIL	Main power fail	The main power failed when the action in case of main power fail is set to warning in the main power input mode setting (0x2006).
 LOW_BATT	Low encoder battery	Encoder battery is low, when applying absolute encoder
 SW_POS_LMT	Software position limit	When using software position limit function, position command larger than the software position value was input.
 OV_DB_CUR	Excessive DB current	DB current exceeding the fault level was output
 OV_LOAD	Operation overload	Accumulated operation overload ratio reached the warning level (0x2010). Check for equipment clash or arrest Check load status, brake action, drive output miss wiring, encoder miss wiring. Check motir ID, drive ID, encoder setting
 SETUP	Driver/motor combination fail	Motor's current capacity is bigger than the drive's current capacity
 UD_VTG	Low voltage	The main power input voltage is under 190V when the action in case of main power fail is set to warning in the main power input mode setting(0x2006).
 EMG	Emergency signalinput	Check emergency stop contact signal, external 24V power

15. Communication Protocol

15.1 Overview and Communication Specifications

15.1.1 Overview

L7P drive is capable of connecting to the host controller (Handy Loader, HMI, PLC, PC, etc.) through RS-422 serial communication, allowing the user to use such functions as commissioning, gain tuning, parameter change and inverter operation.

In addition, up to 31 multiple L7P drives can be connected using multi-drop method, to allow for operation and control through communication.

■ Series Communication Connection using RS-422

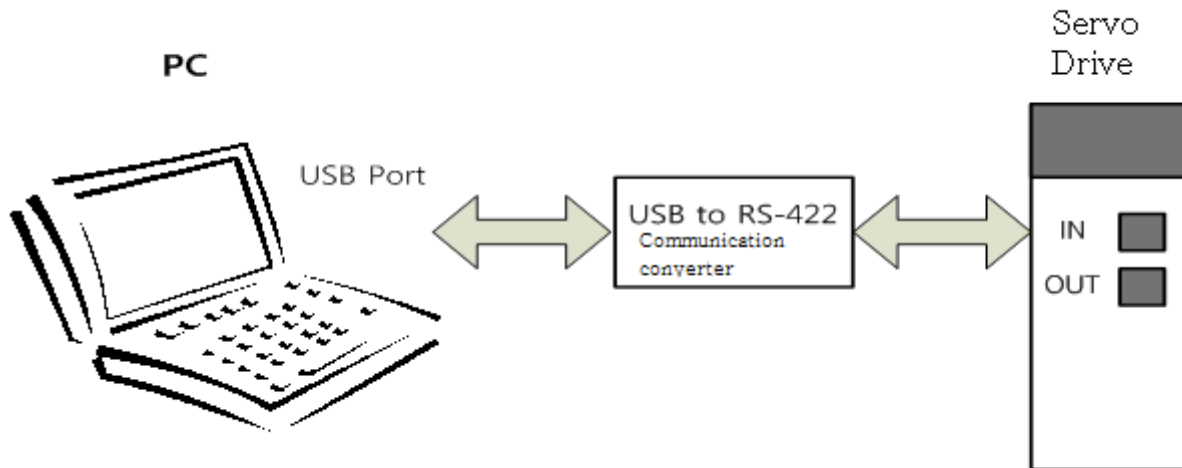

■ Multi-Drop Connection using RS-422 (up to 31 drives)

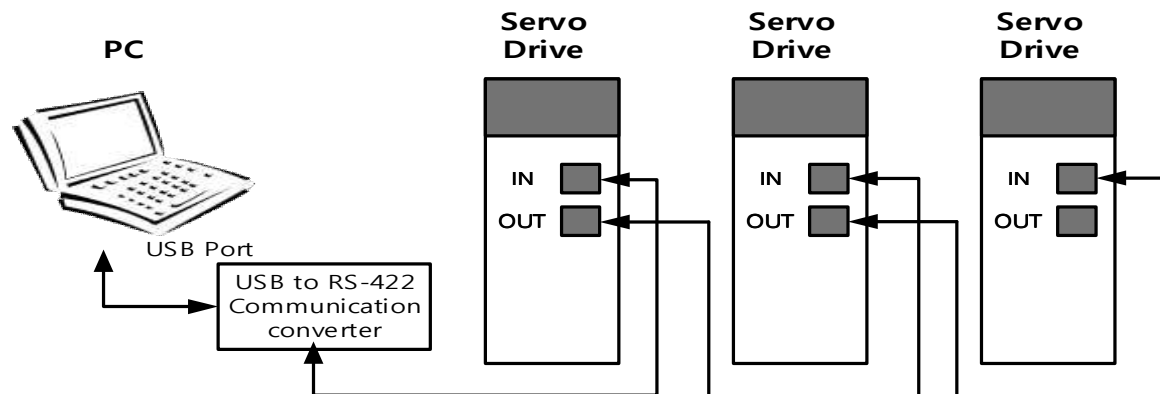

Note 1) When using PC as host controller, USB to RS-422 communication converter is required.

Note 2)The servo drive's IN/OUT connectorpins are internally connected 1 to 1, allowing for convenient multi-drop wiring.

15.1.2 Communication Specifications and Connection Diagram

■ Communication Specifications

Item		Specifications
Communication Standard		ANSI/TIA/EIA-422 Standard
Communication Protocol		MODBUS-RTU
Data Type	Data bit	8bit
	Stop bit	1bit
	Parity	None
Synchro		Asynchronous method
Transmission Speed		9600 /19200/38400/57600 [bps] Speed can be selected at communication speed setting [0x3002]
Transmission Distance		Up to 200 [m]
Power Consumption		Under 100[mA]

■ RS-422 communication connectorpin connection

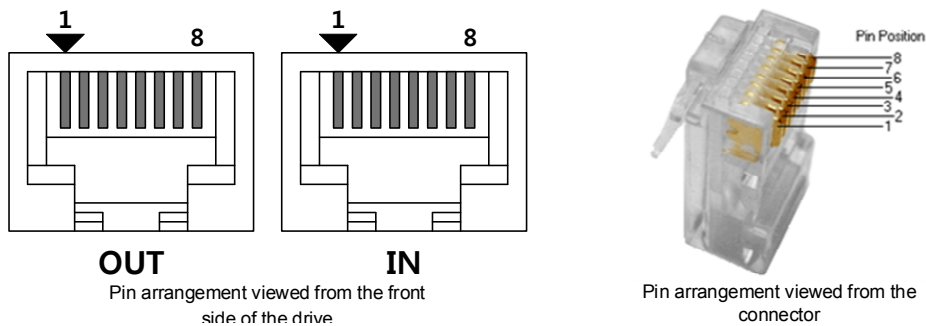

Pin No.	Pin Function	Pin No.	Pin Function
1	Not Used	5	TXD+
2	Not Used	6	RXD-
3	RXD+	7	Not UsedNote 1)
4	TXD-	8	Not UsedNote 1)

Note 3)As for INconnector, 5V voltage is output to Pin No. 7 and Pin No. 8, to supply power to the handy loader. **Use for any other purpose is not allowed, and do not connect Pin No. 7 and Pin No. 8 when wiring.**

Note 4)Connect TXD+ and TXD-, RXD+ and RXD- using twisted pair

Note 5)TXD and RXD of the above table is defined based on the servo drive.

15.2 Basic Structure of Communication Protocol

L7P Drive complies with the MODBUS-RTU Protocol for communication. For issues not specified in this manual, please see the related standards (Related Standard: Modbus Application Protocol Specification 1.1b, 2006.12.28)

In addition, the transmission (Tx) and reception (Rx) concepts are defined in reference to the host.

15.2.1 Transmission/Reception Packet Structure

Maximum length of transmission/reception packet of MODBUS-RTU is 256 Byte. Please make sure the total length of transmission/reception packet does not exceed 256 byte..

To classify packets, MODBUS-RTU Communication Mode requires empty spaces of at least 3.5 characters at the starting point and the end point.

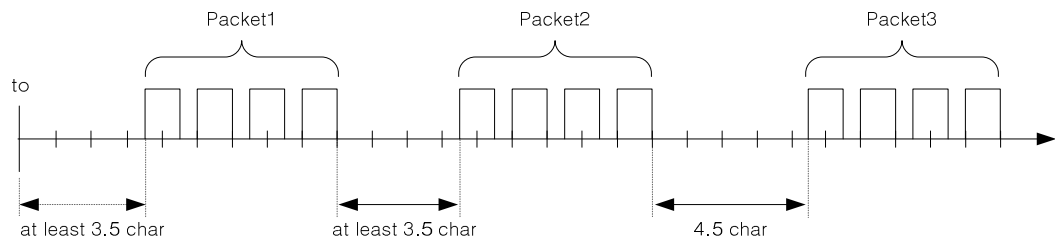

■ Transmission Packet Structure

	Additional Address	Function Code	Data			Error Check	
Byte	0	1	2	.	.	n-1	n
description	Node ID	Function	Data	.	.	CRC(MSB)	CRC(LSB)

■ Reception Packet Structure

[Normal Response]

	Additional Address	Function Code	Data			Error Check	
Byte	0	1	2	.	.	n-1	n
description	Node ID	Function	Data	.	.	CRC(MSB)	CRC(LSB)

[Abnormal Response]

	Additional Address	Function Code	Data	Error Check	
Byte	0	1	2	3	4
description	Node ID	Function+0x80	Exception code	CRC(MSB)	CRC(LSB)

■ Protocol Packet Code Descriptions

- Node ID

This indicates the Node ID of the servo driver to transmit.

The Node ID of servoDrive can be configured with the external switch at the loader window. The set Node ID can be viewed at parameter [0x2003].

- Function Code

Function Codes under Modbus-RTU Standards supported by L7P Drive are as follows.

Category	Comm and Code	Descriptions	Usage	
			Read	Write
PUBLIC Function Code	0x01	Read Coils	○	
	0x02	Read Discrete Inputs	○	
	0x03	Read Holding Registers	○	
	0x04	Read Input Register	○	
	0x05	Write Single Coil		○
	0x06	Write Single Register		○
	0x0F	Write Multiple Coils		○
	0x10	Write Multi Register		○

- Data

[Transmission] :In the case of Read Register command, Modbus address, number of registers, and number of bytes, etc. are designated. In case of Write Register command, Modbus address, number of bytes, and value to set, etc. are designated.

[Reception]: In the case of Read Register command, under normal response, Node ID and Function Code are received as the same values as the transmitted values. The value of each register is received in the order they were transmitted.

In the case of Write Single Register command, the same values as the transmitted values are received. In the case of Write Multi Register, the starting address intended to write the data in with the same values as the transmitted values and the number of registers are received.

Abnormal response consists of Node ID, Error Code and Exception Code. Packet structure of abnormal response is the same regardless of the function code.

- CRC

Inputs 16bitCRC value. The values are divided into MSB/LSB, and transmitted one byte at a time.

- Exception Code

Exception codes for all function code abnormal responses supported by L7P Drive are defined as follows.

Exception Code	Description
0x01	Function Code not supported
0x02	Wrong register address
0x03	Wrong data value
0x04	Device malfunction
0x05	Data not ready
0x06	parameterlocked

15.2.2 Protocol Command Code Descriptions

(1) Read Coils (0x01)

Reads the values of single bit and continuous bit block

Request

Function code	1Byte	0x01
Starting Address	2Byte	0x0000 to 0xFFFF
Quantity of Coils	2Bytes	1 to 2000 (0x7D0)

Request OK

Function code	1Byte	0x01
Byte count	1Byte	N*
Coil Status	n Bytes	n = N or N+1

*N = Quantity of Outputs/8

Response not OK

Error code	1Byte	0x81
Exception code	1Byte	0x01 ~ 0x04

Command code : Read Coils can read status of contacts of drive status input and output 1,2.

The corresponding address of drive status input and output 1,2 are as below.

Drive status input 1, 2 communication address

Communication address		Output contacts	Accessi bility	Communication address		Output contacts	Accessi bility
10진수	16진수			10진수	16진수		
0	0x0000	POT	RW	16	0x0016	START	RW
1	0x0001	NOT	RW	17	0x0017	PAUSE	RW
2	0x0002	HOME	RW	18	0x0018	REGT	RW
3	0x0003	STOP	RW	19	0x0019	HSTART	RW
4	0x0004	PCON	RW	20	0x0020	ISEL0	RW
5	0x0005	GAIN2	RW	21	0x0021	ISEL1	RW
6	0x0006	P_CL	RW	22	0x0022	ISEL2	RW
7	0x0007	N_CL	RW	23	0x0023	ISEL3	RW

8	0x0008	MODE	RW	24	0x0018	ISEL4	RW
9	0x0009	Reserved	RW	25	0x0025	ISEL5	RW
10	0x0010	EMG	RW	26	0x0026	ABSRQ	RW
11	0x0011	A_RST	RW	27	0x0027	JSTART	RW
12	0x0012	SV_ON	RW	28	0x0028	JDIR	RW
13	0x000D	SPD1	RW	29	0x001D	PCLEAR	RW
14	0x000E	SPD2	RW	30	0x001E	AOVR	RW
15	0x000F	SPD3	RW	31	0x001F	Reserved	RW

■ Drive status output 1, 2 communication address

Communication address		Output contacts	Accessi bility	Communication address		Output contacts	Accessi bility
10진수	16진수			10진수	16진수		
32	0x0020	BRAKE	RO	48	0x0030	ORG	RO
33	0x0021	ALARM	RO	49	0x0031	EOS	RO
34	0x0022	READY	RO	50	0x0032	IOUT0	RO
35	0x0023	ZSPD	RO	51	0x0033	IOUT1	RO
36	0x0024	INPOS1	RO	52	0x0034	IOUT2	RO
37	0x0025	TLMT	RO	53	0x0035	IOUT3	RO
38	0x0026	VLMT	RO	54	0x0036	IOUT4	RO
39	0x0027	INSPD	RO	55	0x0037	IOUT5	RO
40	0x0028	WARN	RO	56	0x0038	Reserved	RO
41	0x0029	TGON	RO	57	0x0039	Reserved	RO
42	0x002A	Reserved	RO	58	0x003A	Reserved	RO
43	0x002B	Reserved	RO	59	0x003B	Reserved	RO
44	0x002C	Reserved	RO	60	0x003C	Reserved	RO
45	0x002D	Reserved	RO	61	0x003D	Reserved	RO
46	0x002E	Reserved	RO	62	0x003E	Reserved	RO
47	0x002F	Reserved	RO	63	0x003F	Reserved	RO

For example 1) Reading status of BRAKE output contacts

■ Request

Node ID	Function	Starting Address Hi	Starting Address Lo	Quantity of Register Hi.	Quantity of Register Lo	CRC Hi	CRC Lo
0x01	0x01	0x00	0x20	0x00	0x01	0xFC	0x00

■ Request OK

Node ID	Function	Byte Count	Register Value	CRC Hi	CRC Lo
0x01	0x01	0x01	0x01	0x90	0x48

- The status of BRAKE is High.

■ Response not OK

Node ID	Error Code	Exception Code	CRC Hi	CRC Lo
0x01	0x81	0x01 ~ 0x04	-	-

(2) Read Discrete Inputs (0x02)

Reads the values of single bit and continuous bit block

■ Request

Function code	1Byte	0x02
Starting Address	2Byte	0x0000 to 0xFFFF
Quantity of Registers	2Bytes	1 to 2000 (0x7D0)

■ Request OK

Function code	1Byte	0x02
Starting Address	1Byte	N*
Quantity of Registers	N* x 1 Bytes	

*N = Quantity of Inputs/8

■ Response not OK

Error code	1Byte	0x82
Exception code	1Byte	0x01 ~ 0x04

Command code : Read Discrete Inputs can read status of contacts of drive status input and output1,2

The corresponding address of drive status input and output 1,2 are as below.

■ Drive status input 1, 2 communication address

Communication address		Output contacts	Accessi bility	Communication address		Output contacts	Accessi bility
decimal	Hexa			decimal	Hexa		
0	0x0000	POT	RW	16	0x0010	START	RW
1	0x0001	NOT	RW	17	0x0011	PAUSE	RW
2	0x0002	HOME	RW	18	0x0012	REGT	RW
3	0x0003	STOP	RW	19	0x0013	HSTART	RW
4	0x0004	PCON	RW	20	0x0014	ISEL0	RW
5	0x0005	GAIN2	RW	21	0x0015	ISEL1	RW
6	0x0006	P_CL	RW	22	0x0016	ISEL2	RW
7	0x0007	N_CL	RW	23	0x0017	ISEL3	RW
8	0x0008	MODE	RW	24	0x0018	ISEL4	RW
9	0x0009	Reserved	RW	25	0x0019	ISEL5	RW
10	0x000A	EMG	RW	26	0x001A	ABSRQ	RW
11	0x000B	A_RST	RW	27	0x001B	JSTART	RW
12	0x000C	SV_ON	RW	28	0x001C	JDIR	RW
13	0x000D	SPD1	RW	29	0x001D	PCLEAR	RW
14	0x000E	SPD2	RW	30	0x001E	AOVR	RW
15	0x000F	SPD3	RW	31	0x001F	Reserved	RW

■ Drive status output 1, 2 communication address

Communication address		Output contacts	Accessi bility	Communication address		Output contacts	Accessi bility
decimal	Hexa			decimal	Hexa		
32	0x0020	BRAKE	RO	48	0x0030	ORG	RO
33	0x0021	ALARM	RO	49	0x0031	EOS	RO
34	0x0022	READY	RO	50	0x0032	IOUT0	RO
35	0x0023	ZSPD	RO	51	0x0033	IOUT1	RO
36	0x0024	INPOS1	RO	52	0x0034	IOUT2	RO
37	0x0025	TLMT	RO	53	0x0035	IOUT3	RO
38	0x0026	VLMT	RO	54	0x0036	IOUT4	RO
39	0x0027	INSPD	RO	55	0x0037	IOUT5	RO
40	0x0028	WARN	RO	56	0x0038	Reserved	RO
41	0x0029	TGON	RO	57	0x0039	Reserved	RO

42	0x002A	Reserved	RO	58	0x003A	Reserved	RO
43	0x002B	Reserved	RO	59	0x003B	Reserved	RO
44	0x002C	Reserved	RO	60	0x003C	Reserved	RO
45	0x002D	Reserved	RO	61	0x003D	Reserved	RO
46	0x002E	Reserved	RO	62	0x003E	Reserved	RO
47	0x002F	Reserved	RO	63	0x003F	Reserved	RO

For example 1) Reading status of POT input contacts

■ Request

Node ID	Function	Starting Address Hi	Starting Address Lo	Quantity of Register Hi.	Quantity of Register Lo	CRC Hi	CRC Lo
0x01	0x02	0x00	0x00	0x00	0x01	0XB9	0xCA

■ Request OK

Node ID	Function	Byte Count	Register Value	CRC Hi	CRC Lo
0x01	0x02	0x01	0x00	0xA1	0x88

- The status of POT is Low.

■ Response not OK

Node ID	Error Code	Exception Code	CRC Hi	CRC Lo
0x01	0x82	0x01 ~ 0x04	-	-

(3) Read Holding Register (0x03)

Reads the values of single register (16bit data) and continuous register block (16bit data unit).

■ Request

Function code	1Byte	0x03
Starting Address	2Byte	0x0000 to 0xFFFF
Quantity of Registers	2 Bytes	1 to 125 (0x7D)

■ Request OK

Function code	1Byte	0x03
Starting Address	1Byte	2 x N*

Quantity of Registers	N* x 2 Bytes	
-----------------------	--------------	--

*N = Quantity of Registers

■ **Response not OK**

Error code	1Byte	0x83
Exception code	1Byte	0x01 ~ 0x06

Example1) reading a single parameter (current speed (Address: 0x2600))

■ **Request**

Node ID	Function	Starting Address Hi	Starting Address Lo	Quantity of Register Hi.	Quantity of Register Lo	CRC Hi	CRC Lo
0x01	0x03	0x26	0x00	0x00	0x01	0x8F	0x42

■ **Request OK**

Node ID	Function	Byte Count	Register Value Hi	Register Value Lo	CRC Hi	CRC Lo
0x01	0x03	0x02	0x00	0x00	0xB8	0x44

- The current speed value is 0(or 0x0000).

■ **Response not OK**

Node ID	Error Code	Exception Code	CRC Hi	CRC Lo
0x01	0x83	0x01 ~ 0x06	-	-

Example 2) Reading multiple parameters (motorID(Address: 0x2000), EncoderType(Address: 0x2001), number of encoder pulses per rotation (Address: 0x2002~0x2003))

■ **Request**

Node ID	Function	Starting Address Hi	Starting Address Lo	Quantity of Register Hi.	Quantity of Register Lo	CRC Hi	CRC Lo
0x01	0x03	0x20	0x00	0x00	0x04	0x4F	0xC9

■ **Request OK**

Node ID	Function	Byte Count	Register Value Hi	Register Value Lo	Register Value Hi	Register Value Lo	Register Value Hi	Register Value Lo
0x01	0x03	0x08	0x00	0x0D	0x00	0x02	0x00	0x00

Register Value Hi	Register Value Lo	CRC Hi	CRC Lo
0x00	0x08	0x31	0X11

- motorID(Address: 0x2000) value reads 13(or 0x000D), and Encodertype (Address: 0x2001) value reads 2(or 0x0002). Number of encoder pulses per rotation (Address: 0x2002~0x2003) is a 32bit data, so the data must be swapped once read. Thus, the currently displayed balue 524288(or 0x00080000).

■ **Response not OK**

Node ID	Error Code	Exception Code	CRC Hi	CRC Lo
0x01	0x83	0x01 ~ 0x06	-	-

(2) Read Input Register (0x04)

Reads binary values of single register (16bit data) and continuous register (16bit data unit).

■ Request

Function code	1Byte	0x04
Starting Address	2Byte	0x0000 to 0xFFFF
Quantity of Registers	2 Bytes	0x0000 to 0x007D

■ Request OK

Function code	1Byte	0x04
Starting Address	1Byte	2 x N*
Quantity of Registers	N* x 2 Bytes	

*N = Quantity of Input Registers

■ Response not OK

Error code	1Byte	0x84
Exception code	1Byte	0x01 ~ 0x06

Example1) Reading the parameter value of DriveStatus Output 1(Address: 0x2121)Request

Node ID	Function	Starting Address Hi	Starting Address Lo	Quantity of Register Hi.	Quantity of Register Lo	CRC Hi	CRC Lo
0x01	0x04	0x21	0x21	0x00	0x01	0x6B	0xFC

■ Request OK

Node ID	Function	Byte Count	Register Value Hi	Register Value Lo	CRC Hi	CRC Lo
0x01	0x04	0x02	0x04	0x99	0x7B	0x9A

- DriveStatus Output 1(Address: 0x2121) is 0b10010011001(0x0499): BRAKE, ZSPD, INPOS1, INSPD, INPOS2 contact is output as high(Status 1).

■ Response not OK

Node ID	Error Code	Exception Code	CRC Hi	CRC Lo
0x01	0x84	0x01 ~ 0x06	-	-

(5) Write Single Coil (0x05)

Excute ON or OFF to the value of the single-bit input

■ Request

Function code	1Byte	0x05
Starting Address	2Byte	0x0000 to 0xFFFF
Quantity of Registers	2Bytes	0x0000 or 0xFF00

■ Request OK

Function code	1Byte	0x05
Starting Address	2Byte	0x0000 to 0xFFFF
Quantity of Registers	2Byte	0x0000 or 0xFF00

■ Response not OK

Error code	1Byte	0x85
Exception code	1Byte	0x01 ~ 0x04

Command code : Write Single Coil can control single bit input of drive status input 1, 2.

The corresponding address of drive status input and output 1,2 are as below.

■ Drive status output 1, 2 communication address

Communication address		Output contacts	Accessi bility	Communication address		Output contacts	Accessi bility
decimal	Hexa			decimal	Hexa		
32	0x0020	BRAKE	RO	48	0x0030	ORG	RO
33	0x0021	ALARM	RO	49	0x0031	EOS	RO
34	0x0022	READY	RO	50	0x0032	IOUT0	RO
35	0x0023	ZSPD	RO	51	0x0033	IOUT1	RO
36	0x0024	INPOS1	RO	52	0x0034	IOUT2	RO
37	0x0025	TLMT	RO	53	0x0035	IOUT3	RO

38	0x0026	VLMT	RO	54	0x0036	IOUT4	RO
39	0x0027	INSPD	RO	55	0x0037	IOUT5	RO
40	0x0028	WARN	RO	56	0x0038	Reserved	RO
41	0x0029	TGON	RO	57	0x0039	Reserved	RO
42	0x002A	Reserved	RO	58	0x003A	Reserved	RO
43	0x002B	Reserved	RO	59	0x003B	Reserved	RO
44	0x002C	Reserved	RO	60	0x003C	Reserved	RO
45	0x002D	Reserved	RO	61	0x003D	Reserved	RO
46	0x002E	Reserved	RO	62	0x003E	Reserved	RO
47	0x002F	Reserved	RO	63	0x003F	Reserved	RO

Example 1) Write 'ON' in the state of POT

■ Request

Node ID	Function	Starting Address Hi	Starting Address Lo	Quantity of Register Hi.	Quantity of Register Lo	CRC Hi	CRC Lo
0x01	0x05	0x00	0x00	0xFF	0x00	0X8C	0x3A

■ Request OK

Node ID	Function	Starting Address Hi	Starting Address Lo	Quantity of Register Hi.	Quantity of Register Lo	CRC Hi	CRC Lo
0x01	0x05	0x00	0x00	0xFF	0x00	0X8C	0x3A

■ Response not OK

Node ID	Error Code	Exception Code	CRC Hi	CRC Lo
0x01	0x85	0x01 ~ 0x04	-	-

Example 2) Write 'OFF' in the state of POT

■ Request

Node ID	Function	Starting Address Hi	Starting Address Lo	Quantity of Register Hi.	Quantity of Register Lo	CRC Hi	CRC Lo
0x01	0x05	0x00	0x00	0x00	0x00	0xCD	0xCA

■ Request OK

Node ID	Function	Starting Address Hi	Starting Address Lo	Quantity of Register Hi.	Quantity of Register Lo	CRC Hi	CRC Lo
0x01	0x05	0x00	0x00	0x00	0x00	0XCD	0xCA

■ Response not OK

Node ID	Error Code	Exception Code	CRC Hi	CRC Lo
0x01	0x85	0x01 ~ 0x04	-	-

(6) Write Single Register (0x06)

Writes value in single register (16bit data).

■ Request

Function code	1Byte	0x06
Starting Address	2Bytes	0x0000 to 0xFFFF
Quantity of Registers	2Bytes	0x0000 to 0xFFFF

■ Request OK

Function code	1Byte	0x06
Starting Address	2Bytes	0x0000 to 0xFFFF
Quantity of Registers	2Bytes	0x0000 to 0xFFFF

■ Response not OK

Error code	1Byte	0x86
Exception code	1Byte	0x01 ~ 0x06

Example 1) Changing Inertia Ratio (Address: 0x2100) value to 200

■ Request

Node ID	Function	Starting Address Hi	Starting Address Lo	Quantity of Register Hi.	Quantity of Register Lo	CRC Hi	CRC Lo
0x01	0x06	0x21	0x00	0x00	0xC8	0x82	0x60

■ Request OK

Node ID	Function	Starting Address Hi	Starting Address Lo	Quantity of Register Hi.	Quantity of Register Lo	CRC Hi	CRC Lo
0x01	0x06	0x21	0x00	0x00	0xC8	0x82	0x60

- Changes the inertia ratio (Address: 0x2100) value to 200(or 0x00C8).

■ Response not OK

Node ID	Error Code	Exception Code	CRC Hi	CRC Lo
0x01	0x86	0x01 ~ 0x06	-	-

(7) Write Multiple Coils (0x0F)

Excute ON or OFF to the value of continuative bit input

■ Request

Function code	1Byte	0x0F
Starting Address	2Byte	0x0000 to 0xFFFF
Quantity of Registers	2Bytes	0x0000 or 0xFF00
Byte Count	1Bytes	N*
Outputs Value	N* x 1 Byte	

*N = Quantity of Outputs / 8

■ Request OK

Function code	1Byte	0x0F
Starting Address	2Byte	0x0000 to 0xFFFF
Quantity of Registers	2Byte	0x0001 or 0x07B0

■ Response not OK

Error code	1Byte	0x8F
Exception code	1Byte	0x01 ~ 0x04

Command code : Write Single Coil can control continuous bit input of drive status input 1, 2.

The corresponding address of drive status input and output 1,2 are as below.

■ Drive status input 1, 2 communication address

Communication address		Output contacts	Accessi bility	Communication address		Output contacts	Accessi bility
decimal	Hexa			decimal	Hexa		
0	0x0000	POT	RW	16	0x0010	START	RW
1	0x0001	NOT	RW	17	0x0011	PAUSE	RW
2	0x0002	HOME	RW	18	0x0012	REGT	RW
3	0x0003	STOP	RW	19	0x0013	HSTART	RW
4	0x0004	PCON	RW	20	0x0014	ISEL0	RW
5	0x0005	GAIN2	RW	21	0x0015	ISEL1	RW
6	0x0006	P_CL	RW	22	0x0016	ISEL2	RW

7	0x0007	N_CL	RW	23	0x0017	ISEL3	RW
8	0x0008	MODE	RW	24	0x0018	ISEL4	RW
9	0x0009	Reserved	RW	25	0x0019	ISEL5	RW
10	0x000A	EMG	RW	26	0x001A	ABSRQ	RW
11	0x000B	A_RST	RW	27	0x001B	JSTART	RW
12	0x000C	SV_ON	RW	28	0x001C	JDIR	RW
13	0x000D	SPD1	RW	29	0x001D	PCLEAR	RW
14	0x000E	SPD2	RW	30	0x001E	AOVR	RW
15	0x000F	SPD3	RW	31	0x001F	Reserved	RW

For example 1) Turn ON for POT input contact.

■ Request

Node ID	Function	Starting Address Hi	Starting Address Lo	Quantity of Register Hi.	Quantity of Register Lo	Byte Count
0x01	0x0F	0x00	0x00	0x00	0x0B	0x02

■

Registers Value Hi	Registers Value Lo	CRC Hi	CRC Lo
0X01	0x02	0x64	0x95

■ Request OK

Node ID	Function	Starting Address Hi	Starting Address Lo	Quantity of Register Hi.	Quantity of Register Lo	CRC Hi	CRC Lo
0x01	0x05	0x00	0x00	0x00	0x0B	0X14	0x0C

■ Response not OK

Node ID	Error Code	Exception Code	CRC Hi	CRC Lo
0x01	0x8F	0x01 ~ 0x04	-	-

(8) Write Multi Register (0x10)

Writes value in continuous register block (16bit data unit).

■ Request

Function code	1Byte	0x10
Starting Address	2Bytes	0x0000 to 0xFFFF
Quantity of Registers	2Bytes	0x0001 to 0x007B
Byte Count	1Byte	2 x N*
Registers Value	N* x 2 Bytes	value

*N = Quantity of Registers

■ Request OK

Function code	1Byte	0x10
Starting Address	2Byte	0x0000 to 0xFFFF
Quantity of Registers	2Byte	1 to 123 (0x7B)

■ Response not OK

Error code	1Byte	0x90
Exception code	1Byte	0x01 ~ 0x06

Example 1) Writing multiple parameter values (JogSpeed(Address: 0x2300), JogAccelerationTime(Address: 0x2301), JogDeceleration Speed(Address: 0x2302))

■ Request

Node ID	Function	Starting Address Hi	Starting Address Lo	Quantity of Register Hi.	Quantity of Register Lo	Byte Count
0x01	0x10	0x23	0x00	0x00	0x03	0x06

Registers Value Hi	Registers Value Lo	Registers Value Hi	Registers Value Lo	Registers Value Hi	Registers Value Lo	CRC Hi	CRC Lo
0XF4	0x48	0x00	0x64	0x00	0x64	0XF7	0X4A

- Jogspeed(Address: 0x2300) value is changed to -3000(or 0xF448), and jogaccelerationtime(Address: 0x2301) and jog deceleration time(Address: 0x2300) were changed to 100(or 0x0064).

■ Request OK

Node ID	Function	Starting Address Hi	Starting Address Lo	Quantity of Register Hi.	Quantity of Register Lo	CRC Hi	CRC Lo
0x01	0x10	0x23	0x00	0x00	0x03	0X8B	0X8C

■ Response not OK

Node ID	Error Code	Exception Code	CRC Hi	CRC Lo
0x01	0x90	0x01 ~ 0x06	-	-

15.3 L7P Indexer Servo Drive Communication Address Table

15.3.1 System Configuration Parameters

communication address		parameter name	parameter No.	Variable Format	Default Value	Min	Max	Unit	Accessibility
decimal	hexadecimal								
8192	0x2000	Motor ID	0x2000	UINT	13	1	9999	-	RW
8193	0x2001	Encoder Type	0x2001	UINT	1	0	99	-	RW
8194	0x2002	Encoder Pulse per Revolution	0x2002	UDINT	4096	0	1073741824	pulse	RW
8196	0x2004	Node ID	0x2003	UINT	-	0	65535		RO
8197	0x2005	Rotation Direction Select	0x2004	UINT	0	0	1	-	RW
8198	0x2006	Absolute Encoder Configuration	0x2005	UINT	0	0	1	-	RW
8199	0x2007	Main Power Fail Check Mode	0x2006	UINT	0	0	255	-	RW
8200	0x2008	Main Power Fail Check Time	0x2007	UINT	20	0	5000	ms	RW
8201	0x2009	7SEG Display Selection	0x2008	UINT	0	0	100	-	RW
8202	0x200A	Regeneration Brake Resistor Configuration	0x2009	UINT	0	0	1	-	RW
8203	0x200B	Regeneration Brake Resistor Derating Factor	0x200A	UINT	100	0	200	%	RW
8204	0x200C	Regeneration Brake Resistor Value	0x200B	UINT	0	0	100	ohm	RW
8205	0x200D	Regeneration Brake Resistor Power	0x200C	UINT	0	0	30000	watt	RW
8206	0x200E	Peak Power of Regeneration Brake Resistor	0x200D	UINT	100	1	50000	watt	RW
8207	0x200F	Duration Time @ Peak Power of Regeneration Brake Resistor	0x200E	UINT	5000	1	50000	ms	RW
8208	0x2010	Overload Check Base	0x200F	UINT	100	10	120	%	RW
8209	0x2011	Overload Warning Level	0x2010	UINT	50	10	100	%	RW
8210	0x2012	PWM Off Delay Time	0x2011	UINT	10	0	1000	ms	RW
8211	0x2013	Dynamic Brake Control Mode	0x2012	UINT	0	0	3	-	RW
8212	0x2014	Emergency Stop Configuration	0x2013	UINT	1	0	1	-	RW
8213	0x2015	Warning Mask Configuration	0x2014	UINT	0	0	0xFFFF	-	RW
8214	0x2016	U Phase Current Offset	0x2015	INT	0	-1000	1000	0.10%	RW

8215	0x2017	V Phase Current Offset	0x2016	INT	0	-1000	1000	0.10%	RW
8216	0x2018	W Phase Current Offset	0x2017	INT	0	-1000	1000	0.10%	RW
8217	0x2019	Magnetic Pole Pitch	0x2018	UINT	2400	1	65535	0.01mm	RW
8218	0x201A	Linear Scale Resolution	0x2019	UINT	1000	1	65535	nm	RW
8219	0x201B	Commutation Method	0x201A	UINT	0	0	2	-	RW
8220	0x201C	Commutation Current	0x201B	UINT	500	0	1000	0.10%	RW
8221	0x201D	Commutation Time	0x201C	UINT	1000	500	5000	ms	RW
8222	0x201E	Grating Period of Sinusoidal Encoder	0x201D	UINT	40	1	65535	Um	RW
8223	0x201F	Homing Done Behaviour	0x201E	UINT	0	0	1	-	RW
8224	0x2020	Velocity Function Select	0x201F	UINT	0	0	2	-	RW
8225	0x2021	Motor Hall Phase Config	0x2020	UINT	0	0	1	-	RW

15.3.2 Control Parameters

communication address		parameter name	parameter No.	Variable Format	Default Value	Min	Max	Unit	Accessibility
decimal	hexadecimal								
8448	0x2100	Inertia Ratio	0x2100	UINT	100	0	3000	%	RW
8449	0x2101	Position Loop Gain 1	0x2101	UINT	50	0	500	1/s	RW
8450	0x2102	Speed Loop Gain 1	0x2102	UINT	75	0	2000	Hz	RW
8451	0x2103	Speed Loop Integral Time Constant 1	0x2103	UINT	50	1	1000	ms	RW
8452	0x2104	Torque Command Filter Time Constant 1	0x2104	UINT	0	0	1000	0.1ms	RW
8453	0x2105	Position Loop Gain 2	0x2105	UINT	30	0	500	1/s	RW
8454	0x2106	Speed Loop Gain 2	0x2106	UINT	50	0	2000	Hz	RW
8455	0x2107	Speed Loop Integral Time Constant 2	0x2107	UINT	50	1	1000	ms	RW
8456	0x2108	Torque Command Filter Time Constant 2	0x2108	UINT	0	0	1000	0.1ms	RW
8457	0x2109	Position Command Filter Time Constant	0x2109	UINT	0	0	1000	0.1ms	RW
8458	0x210A	Position Command Average	0x210A	UINT	0	0	1000	0.1ms	RW

		Filter Time Constant							
8459	0x210B	Speed Feedback Filter Time Constant	0x210B	UINT	2	0	1000	0.1ms	RW
8460	0x210C	Speed Feed-forward Gain	0x210C	UINT	0	0	100	%	RW
8461	0x210D	Speed Feed-forward Filter Time Constant	0x210D	UINT	10	0	1000	0.1ms	RW
8462	0x210E	Torque Feed-forward Gain	0x210E	UINT	0	0	100	%	RW
8463	0x210F	Torque Feed-forward Filter Time Constant	0x210F	UINT	10	0	1000	0.1ms	RW
8464	0x2110	Torque Limit Function Select	0x2110	UINT	2	0	4	-	RW
8465	0x2111	External Positive Torque Limit Value	0x2111	UINT	3000	0	5000	0.1%	RW
8466	0x2112	External Negative Torque Limit Value	0x2112	UINT	3000	0	5000	0.1%	RW
8467	0x2113	Emergency Stop Torque	0x2113	UINT	1000	0	5000	0.1%	RW
8468	0x2114	P/PI Control Conversion Mode	0x2114	UINT	0	0	4	-	RW
8469	0x2115	P Control Switch Torque	0x2115	UINT	500	0	5000	0.1%	RW
8470	0x2116	P Control Switch Speed	0x2116	UINT	100	0	6000	rpm	RW
8471	0x2117	P Control Switch Acceleration	0x2117	UINT	1000	0	60000	rpm/s	RW
8472	0x2118	P Control Switch Following Error	0x2118	UINT	100	0	60000	pulse	RW
8473	0x2119	Gain Conversion Mode	0x2119	UINT	0	0	7	-	RW
8474	0x211A	Gain Conversion Time 1	0x211A	UINT	2	0	1000	ms	RW
8475	0x211B	Gain Conversion Time 2	0x211B	UINT	2	0	1000	ms	RW
8476	0x211C	Gain Conversion Waiting Time 1	0x211C	UINT	0	0	1000	ms	RW
8477	0x211D	Gain Conversion Waiting Time 2	0x211D	UINT	0	0	1000	ms	RW
8478	0x211E	Dead Band for Position Control	0x211E	UINT	0	0	1000	UU	RW
8479	0x211F	Drive Control Input 1	0x211F	UINT	0	0	0xFF F	-	RW
8480	0x2120	Drive Control Input 2	0x2120	UINT	0	0	0xFF F	-	RW

8481	0x2121	Drive Status Output 1	0x2121	UINT	0	0	0xFFF F	-	RO
8482	0x2122	Drive Status Output 2	0x2122	UINT	0	0	0xFFF F	-	RO

15.3.3 Input and Output Parameters

communication address		parameter name	parameter No.	Variable Format	Default Value	Min	Max	Unit	Accessibility
decimal	hexadecimal								
8704	0x2200	Digital Input Signal 1 Selection	0x2200	UINT	0x000F	0	0xFFFF	-	RW
8705	0x2201	Digital Input Signal 2 Selection	0x2201	UINT	0x0001	0	0xFFFF	-	RW
8706	0x2202	Digital Input Signal 3 Selection	0x2202	UINT	0x0002	0	0xFFFF	-	RW
8707	0x2203	Digital Input Signal 4 Selection	0x2203	UINT	0x000C	0	0xFFFF	-	RW
8708	0x2204	Digital Input Signal 5 Selection	0x2204	UINT	0x0001	0	0xFFFF	-	RW
8709	0x2205	Digital Input Signal 6 Selection	0x2205	UINT	0x0010	0	0xFFFF	-	RW
8710	0x2206	Digital Input Signal 7 Selection	0x2206	UINT	0x0012	0	0xFFFF	-	RW
8711	0x2207	Digital Input Signal 8 Selection	0x2207	UINT	0x0011	0	0xFFFF	-	RW
8712	0x2208	Digital Input Signal 9 Selection	0x2208	UINT	0x0003	0	0xFFFF	-	RW
8713	0x2209	Digital Input Signal 10 Selection	0x2209	UINT	0x0013	0	0xFFFF	-	RW
8714	0x220A	Digital Input Signal 11 Selection	0x220A	UINT	0x0014	0	0xFFFF	-	RW
8715	0x220B	Digital Input Signal 12 Selection	0x220B	UINT	0x0015	0	0xFFFF	-	RW
8716	0x220C	Digital Input Signal 13 Selection	0x220C	UINT	0x0016	0	0xFFFF	-	RW
8717	0x220D	Digital Input Signal 14 Selection	0x220D	UINT	0x0017	0	0xFFFF	-	RW
8718	0x220E	Digital Input Signal 15 Selection	0x220E	UINT	0x0018	0	0xFFFF	-	RW
8719	0x220F	Digital Input Signal 16 Selection	0x220F	UINT	0x0019	0	0xFFFF	-	RW
8720	0x2210	Digital Output Signal 1 Selection	0x2210	UINT	0x8002	0	0xFFFF	-	RW
8721	0x2211	Digital Output Signal 2 Selection	0x2211	UINT	0x0003	0	0xFFFF	-	RW
8722	0x2212	Digital Output Signal 3 Selection	0x2212	UINT	0x8001	0	0xFFFF	-	RW
8723	0x2213	Digital Output Signal 4 Selection	0x2213	UINT	0x0005	0	0xFFFF	-	RW
8724	0x2214	Digital Output Signal 5 Selection	0x2214	UINT	0x0010	0	0xFFFF	-	RW
8725	0x2215	Digital Output Signal 6 Selection	0x2215	UINT	0x0011	0	0xFFFF	-	RW
8726	0x2216	Digital Output Signal 7 Selection	0x2216	UINT	0x000A	0	0xFFFF	-	RW
8727	0x2217	Digital Output Signal 8 Selection	0x2217	UINT	0x0006	0	0xFFFF	-	RW
8728	0x2218	Analog Torque	0x221C	UINT	100	0	0xFFFF	0.1%/V	RW

		Input(command/limit) Scale							
8729	0x2219	Analog Torque Input(command/limit) Offset	0x221D	INT	0	-1000	1000	mV	RW
8730	0x221A	Analog Velocity Override Mode	0x221E	UINT	0	0	1	-	RW
8731	0x221B	Analog Velocity Input(command/override) Offset	0x221F	INT	0	-1000	1000	mV	RW
8732	0x221C	Analog Monitor Output Mode	0x2220	UINT	0	0	1	-	RW
8733	0x221D	Analog Monitor Channel 1 Select	0x2221	UINT	0	0	65535	-	RW
8734	0x221E	Analog Monitor Channel 2 Select	0x2222	UINT	1	0	65535	-	RW
8736	0x2220	Analog Monitor Channel 1 Offset	0x2223	DINT	0	0	0x4000000 0	-	RW
8738	0x2222	Analog Monitor Channel 2 Offset	0x2224	DINT	0	0	0x4000000 0	-	RW
8740	0x2224	Analog Monitor Channel 1 Scale	0x2225	UDINT	500	0	0x4000000 0	-	RW
8742	0x2226	Analog Monitor Channel 2 Scale	0x2226	UDINT	500	0	0x4000000 0	-	RW
8744	0x2228	Analog Velocity Command Filter Time Constant	0x2227	UINT	2	0	1000	-	RW
8745	0x2229	Analog Torque Command Filter Time Constant	0x2228	UINT	2	0	1000	-	RW
8746	0x222A	Analog Velocity Command Scale	0x2229	INT	100	0	1000	-	RW
8747	0x222B	Analog Velocity Command Clamp Level	0x222A	UINT	0	0	100	-	RW

15.3.4 Speed Operation Parameters

communication address		parameter name	parameter No.	Variable Format	Default Value	Min	Max	Unit	Accessibility
decimal	hexadecimal								
8960	0x2300	Jog Operation Speed	0x2300	INT	500	-6000	6000	rpm	RW
8961	0x2301	Speed Command Acceleration Time	0x2301	UINT	200	0	10000	ms	RW

8962	0x2302	Speed Command Deceleration Time	0x2302	UINT	200	0	10000	ms	RW
8963	0x2303	Speed Command S-curve Time	0x2303	UINT	0	0	1000	ms	RW
8964	0x2304	Program Jog Operation Speed 1	0x2304	INT	0	-6000	6000	rpm	RW
8965	0x2305	Program Jog Operation Speed 2	0x2305	INT	500	-6000	6000	rpm	RW
8966	0x2306	Program Jog Operation Speed 3	0x2306	INT	0	-6000	6000	rpm	RW
8967	0x2307	Program Jog Operation Speed 4	0x2307	INT	-500	-6000	6000	rpm	RW
8968	0x2308	Program Jog Operation Time 1	0x2308	UINT	500	0	10000	ms	RW
8969	0x2309	Program Jog Operation Time 2	0x2309	UINT	5000	0	10000	ms	RW
8970	0x230A	Program Jog Operation Time 3	0x230A	UINT	500	0	10000	ms	RW
8971	0x230B	Program Jog Operation Time 4	0x230B	UINT	5000	0	10000	ms	RW
8972	0x230C	Index Pulse Search Speed	0x230C	INT	20	-1000	1000	rpm	RW
8973	0x230D	Speed Limit Function Select	0x230D	UINT	0	0	3	-	RW
8974	0x230E	Speed Limit Value at Torque Control Mode	0x230E	UINT	1000	0	6000	rpm	RW
8975	0x230F	Over Speed Dection Level	0x230F	UINT	6000	0	10000	rpm	RW
8976	0x2310	Excessive Speed Error Detection Level	0x2310	UINT	5000	0	10000	rpm	RW
8977	0x2311	Servo-Lock Function Select	0x2311	UINT	0	0	1	-	RW
8978	0x2312	Multi-Step Operation Speed 1	0x2312	INT	0	-32768	32767	rpm	RW
8979	0x2313	Multi-Step Operation Speed 2	0x2313	INT	10	-32768	32767	rpm	RW
8980	0x2314	Multi-Step Operation Speed 3	0x2314	INT	50	-32768	32767	rpm	RW
8981	0x2315	Multi-Step Operation Speed 4	0x2315	INT	100	-32768	32767	rpm	RW
8982	0x2316	Multi-Step Operation Speed 5	0x2316	INT	200	-32768	32767	rpm	RW
8983	0x2317	Multi-Step Operation Speed 6	0x2317	INT	500	-32768	32767	rpm	RW
8984	0x2318	Multi-Step Operation Speed 7	0x2318	INT	1000	-32768	32767	rpm	RW
8985	0x2319	Multi-Step Operation Speed 8	0x2319	INT	1500	-32768	32767	rpm	RW
8986	0x231A	Velocity Command Switch Select	0x231A	UINT	0	0	3	-	RW
								-	

15.3.5 Miscellaneous Parameters

communication address		parameter name	parameter No.	Variable Format	Default Value	Min	Max	Unit	Accessibility
decimal	hexadecimal								
9216	0x2400	Software Position Limit Function Select	0x2400	UINT	0	0	3	-	RW
9217	0x2401	INPOS1 Output Range	0x2401	UINT	100	0	60000	UU	RW

9218	0x2402	INPOS1 Output Time	0x2402	UINT	0	0	1000	ms	RW
9219	0x2403	INPOS2 Output Range	0x2403	UINT	100	0	60000	UU	RW
9220	0x2404	ZSPD Output Range	0x2404	UINT	10	0	6000	rpm	RW
9221	0x2405	TGON Output Range	0x2405	UINT	100	0	6000	rpm	RW
9222	0x2406	INSPD Output Range	0x2406	UINT	100	0	6000	rpm	RW
9223	0x2407	BRAKE Output Speed	0x2407	UINT	100	0	6000	rpm	RW
9224	0x2408	BRAKE Output Delay Time	0x2408	UINT	100	0	1000	ms	RW
9225	0x2409	Torque Limit at Homing Using Stopper	0x2409	UINT	250	0	2000	0.10%	RW
9226	0x240A	Duration Time at Homing Using Stopper	0x240A	UINT	50	0	1000	ms	RW
9227	0x240B	Modulo Mode	0x240B	UINT	0	0	3	-	RW
9228	0x240C	Modulo Factor	0x240C	DINT	3600	1	0x3FFFFFFF	UU	RW
9230	0x240E	User Drive Name	0x240D	STRING	Drive			UU	RW
9238	0x2416	Individual Parameter Store	0x240E	UINT	0	0	1	-	RW

15.3.6 Advanced Control Parameters

communication address		parameter name	parameter No.	Variable Format	Default Value	Min	Max	Unit	Accessibility
decimal	hexadecimal								
9472	0x2500	Adaptive Filter Function Select	0x2500	UINT	0	0	5	-	RW
9473	0x2501	Notch Filter 1 Frequency	0x2501	UINT	5000	50	5000	Hz	RW
9474	0x2502	Notch Filter 1 Width	0x2502	UINT	1	1	100	Hz	RW
9475	0x2503	Notch Filter 1 Depth	0x2503	UINT	1	1	5	-	RW
9476	0x2504	Notch Filter 2 Frequency	0x2504	UINT	5000	50	5000	Hz	RW
9477	0x2505	Notch Filter 2 Width	0x2505	UINT	1	1	100	Hz	RW
9478	0x2506	Notch Filter 2 Depth	0x2506	UINT	1	1	5	-	RW
9479	0x2507	Notch Filter 3 Frequency	0x2507	UINT	5000	50	5000	Hz	RW
9480	0x2508	Notch Filter 3 Width	0x2508	UINT	1	1	100	Hz	RW
9481	0x2509	Notch Filter 3 Depth	0x2509	UINT	1	1	5	-	RW
9482	0x250A	Notch Filter 4 Frequency	0x250A	UINT	5000	50	5000	Hz	RW
9483	0x250B	Notch Filter 4 Width	0x250B	UINT	1	1	100	Hz	RW
9484	0x250C	Notch Filter 4 Depth	0x250C	UINT	1	1	5	-	RW

9485	0x250D	On-line Gain Tuning Mode	0x250D	UINT	0	0	1	-	RW
9486	0x250E	System Rigidity for Gain Tuning	0x250E	UINT	5	1	20	-	RW
9487	0x250F	On-line Gain Tuning Adaptation Speed	0x250F	UINT	1	1	5	-	RW
9488	0x2510	Off-line Gain Tuning Direction	0x2510	UINT	0	0	1	-	RW
9489	0x2511	Off-line Gain Tuning Distance	0x2511	UINT	5	1	10	-	RW
9490	0x2512	Disturbance Observer Gain	0x2512	UINT	0	0	100	%	RW
9491	0x2513	Disturbance Observer Filter Time Constant	0x2513	UINT	10	0	1000	0.1ms	RW
9492	0x2514	Current Controller Gain	0x2514	UINT	100	1	150	%	RW
9493	0x2515	Vibration Suppression Filter Configuration	0x2515	UINT	0	0	5	-	RW
9494	0x2516	Vibration Suppression Filter 1 Frequency	0x2516	UINT	0	0	2000	0.1Hz	RW
9495	0x2517	Vibration Suppression Filter 1 Damping	0x2517	UINT	0	0	5	-	RW
9496	0x2518	Vibration Suppression Filter 2 Frequency	0x2518	UINT	0	0	2000	0.1Hz	RW
9497	0x2519	Vibration Suppression Filter 2 Damping	0x2519	UINT	0	0	5	-	RW

15.3.7 Monitoring Parameters

communication address		parameter name	parameter No.	Variable Format	Default Value	Min	Max	Unit	Accessibility
decimal	hexadecimal								
9728	0x2600	Feedback Speed	0x2600	INT	-	-	-	rpm	RO
9729	0x2601	Command Speed	0x2601	INT	-	-	-	rpm	RO
9730	0x2602	Following Error	0x2602	DINT	-	-	-	pulse	RO
9732	0x2604	Accumulated Operation Overload	0x2603	INT	-	-	-	0.10%	RO
9733	0x2605	Instantaneous Maximum Operation Overload	0x2604	INT	-	-	-	0.10%	RO
9734	0x2606	DC-Link Voltage	0x2605	UINT	-	-	-	Volt	RO
9735	0x2607	Accumulated Regeneration Overload	0x2606	INT	-	-	-	0.10%	RO
9736	0x2608	SingleTurn Data	0x2607	UDINT	-	-	-	pulse	RO
9738	0x260A	Mechanical Angle	0x2608	UINT	-	-	-	0.1deg	RO
9739	0x260B	Electrical Angle	0x2609	INT	-	-	-	0.1deg	RO
9740	0x260C	MultiTurn Data	0x260A	DINT	-	-	-	rev	RO
9742	0x260E	Drive Temperature 1	0x260B	INT	-	-	-	°C	RO
9743	0x260F	Drive Temperature 2	0x260C	INT	-	-	-	°C	RO
9744	0x2610	Encoder Temperature	0x260D	INT	-	-	-	°C	RO

9745	0x2611	Motor Rated Speed	0x260E	UINT	-	-	-	rpm	RO
9746	0x2612	Motor Maximum Speed	0x260F	UINT	-	-	-	rpm	RO
9747	0x2613	Drive Rated Current	0x2610	UINT	-	-	-	0.1A	RO
9748	0x2614	FPGA Version	0x2611	STRING	-	-	-	-	RO
9751	0x2617	Hall Signal Display	0x2612	UINT	-	-	-	-	RO
9752	0x2618	Bootloader Version	0x2613	STRING	-	-	-	-	RO
9755	0x261B	Warning Code	0x2614	UINT	-	-	-	-	RO
9756	0x261C	Analog Input 1 Value	0x2615	INT	-	-	-	mV	RO
9757	0x261D	Analog Input 2 Value	0x2616	INT	-	-	-	mV	RO

15.3.8 Procedures and Alarm History

communication address		parameter name	parameter No.	Variable Format	Default Value	Min	Max	Unit	Accessibility
decimal	hexadecimal								
9984	0x2700	Procedure Command Code	0x2700	UINT	0	0	0xFFFF	-	RW
9985	0x2701	Procedure Command Argument	0x2701	UINT	0	0	0xFFFF	-	RW

15.3.9 3rd Party Motor Parameters

communication address		parameter name	parameter No.	Variable Format	Default Value	Min	Max	Unit	Accessibility
decimal	hexadecimal								
10240	0x2800	[Third Party Motor] Type	0x2800	UINT	0	0	1	-	RW
10241	0x2801	[Third Party Motor] Number of Poles	0x2801	UINT	8	2	1000	-	RW
10242	0x2802	[Third Party Motor] Rated Current	0x2802	FP32	2.89	-	-	Arms	RW
10244	0x2804	[Third Party Motor] Maximum Current	0x2803	FP32	8.67	-	-	Arms	RW
10246	0x2806	[Third Party Motor] Rated Speed	0x2804	UINT	3000	1	60000	rpm	RW

10247	0x2807	[Third Party Motor] Maximum Speed	0x2805	UINT	5000	1	60000	rpm	RW
10248	0x2808	[Third Party Motor] Inertia	0x2806	FP32	0.321	-	-	Kg	RW
10250	0x280A	[Third Party Motor] Torque Constant	0x2807	FP32	0.46	-	-	Kg.m2.10 -4	RW
10252	0x280C	[Third Party Motor] Phase Resistance	0x2808	FP32	0.82	-	-	ohm	RW
10254	0x280E	[Third Party Motor] Phase Inductance	0x2809	FP32	3.66	0	1000	Mh	RW
10256	0x2810	[Third Party Motor] TN Curve Data 1	0x280A	UINT	3000	1	60000	rpm	RW
10258	0x2812	[Third Party Motor] TN Curve Data 2	0x280B	FP32	100	-	-	%	RW
10260	0x2814	[Third Party Motor] Hall Offset	0x280C	UINT	0	0	360	deg	RW

15.3.10 CiA402 parameters

communication address		parameter name	parameter No.	Variable Format	Default Value	Min	Max	Unit	Accessibility
decimal	hexadecimal								
24576	0x6000	Error Code	0x603F	UINT	0	-	-	-	RO
24577	0x6001	Controlword	0x6040	UINT	0	0	65535	-	RW
24578	0x6002	Statusword	0x6041	UINT	-	-	-	-	RO
24579	0x6003	Quick Stop Option Code	0x605A	INT	2	0	4	-	RW
24580	0x6004	Shutdown Option Code	0x605B	INT	0	1	1	-	RW
24581	0x6005	Disable Operation Option Code	0x605C	INT	1	0	1	-	RW
24582	0x6006	Halt Option Code	0x605D	INT	0	0	4	-	RW
24583	0x6007	Fault Reaction Option Coed	0x605E	INT	0	0	0	-	RW
24584	0x6008	Modes of Operation	0x6060	SINT	0	0	10	-	RW
24585	0x6009	Modes of Operation Display	0x6061	SINT	-	-	-	-	RO
24586	0x600A	Position Demand Valude	0x6062	DINT	-	-	-	UU	RO
24588	0x600C	Position Actual Internal Value	0x6063	DINT	-	-	-	Pulse	RO
24590	0x600E	Position Actual Value	0x6064	DINT	-	-	-	UU	RO
24592	0x6010	Following Error Window	0x6065	UDINT	600000	0	107374182 3	UU	RW
24594	0x6012	Following Error Timeout	0x6066	UINT	0	0	65535	ms	RW
24595	0x6013	Position Window	0x6067	UDINT	100	0	107374182 3	UU	RW
24597	0x6015	Position Window Time	0x6068	UINT	0	0-	65535	ms	RW
24598	0x6016	Speed Demand Value	0x606B	DINT	-	-	-	UU/s	RO

24600	0x6018	Speed Actual Value	0x606C	DINT	-	-	-	UU/s	RO
24602	0x601A	Speed Window	0x606D	UINT	20000	0	65535	UU/s	RW
24603	0x601B	Speed Window Time	0x606E	UINT	0	0	65535	ms	RW
24604	0x601C	Target Torque	0x6071	INT	0	-5000	5000	0.1%	RW
24605	0x601D	Maximum Torque	0x6072	UINT	3000	0	5000	0.1%	RW
24606	0x601E	Torque Demand Value	0x6074	INT	-	-	-	0.1%	RO
24607	0x601F	Torque Actual Value	0x6077	INT	-	-	-	0.1%	RO
24608	0x6020	Target Position	0x607A	DINT	0	214748364 8	214748364 7	UU	RW
24610	0x6022	Home Offset	0x607C	DINT	0	- 536870912	536870911	UU	RW
24614	0x6026	Software Position Limit (Min)	0x607D:01	DINT	- 20000000000	- 107374182 4	107374182 4	UU	RW
24616	0x6028	Software Position Limit (Max)	0x607D:02	DINT	20000000000	- 107374182 4	107374182 4	UU	RW
24618	0x602A	Max Profile Speed	0x607F	DINT	0x7FFFFFFF	0	0x7FFFFFFF F	UU/s	RW
24620	0x602C	Profile Speed	0x6081	DINT	200000	0	0x7FFFFFFF F	UU/s	RW
24622	0x602E	Profile Acceleration	0x6083	DINT	200000	0	0x7FFFFFFF F	UU/s ²	RW
24624	0x6030	Profile Deceleration	0x6084	DINT	200000	0	0x7FFFFFFF F	UU/s ²	RW
24626	0x6032	Quick Stop Deceleration	0x6085	DINT	2000	0	0x7FFFFFFF F	UU/s ²	RW
24628	0x6034	Torque Slope	0x6087	DINT	1000	0	0x7FFFFFFF F	0.1%/s	RW
24632	0x6038	Gear Ratio (Motor revolutions)	0x6091:01	UDINT	1	0	0x40000000	-	RO
24634	0x603A	Gear Ratio (Shaft revolutions)	0x6091:02	UDINT	1	0	0x40000000	-	RO
24636	0x603C	Homing Method	0x6098	INT	34	-128	127	-	RW
24639	0x603F	Homing Speed (switch)	0x6099:01	DINT	500000	0	0x40000000	UU/s	RW
24641	0x6041	Homing Speed (zero)	0x6099:02	DINT	100000	0	0x40000000	UU/s	RW
24643	0x6043	Homing Acceleration	0x609A	UDINT	200000	0	0x40000000	UU/s ²	RW
24645	0x6045	Position Offset	0x60B0	DINT	0	-	214748364	UU	RW

						214748364	8		
						8			
24647	0x6047	Speed Offset	0x60B1	DINT	0	- 214748364	214748364 8	UU/s	RW
24648	0x6049	Torque Offset	0x60B2	INT	0	-5000	5000	0.1%	RW
24649	0x604A	Touch Probe Function	0x60B8	UINT	0x0033	0	0xFFFF	-	RW
24650	0x604B	Touch Probe Status	0x60B9	UINT	-	-	-	-	RO
24651	0x604C	Touch Prove 1 Positive Edge Position Value	0x60BA	DINT	-	-	-	UU	RO
24653	0x604E	Touch Prove 1 Negative Edge Position Value	0x60BB	DINT	-	-	-	UU	RO
24655	0x6050	Touch Prove 2 Positive Edge Position Value	0x60BC	DINT	-	-	-	UU	RO
24657	0x6052	Touch Prove 2 Negative Edge Position Value	0x60BD	DINT	-	-	-	UU	RO
24666	0x605A	Positive Torque Limit Value	0x60E0	UINT	1000	0	5000	0.1%	RW
24667	0x605B	Negative Torque Limit Value	0x60E1	UINT	1000	0	5000	0.1%	RW
24668	0x605C	Following Error Actual Value	0x60F4	DINT	-	-	-	UU	RO
24670	0x605E	Position Demand Internal Value	0x60FC	DINT	-	-	-	Pulse	RO
24672	0x6060	Digital Inputs	0x60FD	UDINT	-	-	-	-	RO
24676	0x6064	Disital Outputs (Physical)	0x60FE	DINT	0	0	0xFFFFFFFF F	-	RW
24678	0x6066	Disital Outputs (Bit mask)	0x60FE	DINT	0	0	0xFFFFFFFF F	-	RW
24680	0x6068	Target Speed	0x60FF	DINT	0	- 214748364	214748364 8	UU/s	RW
24682	0x606A	Supported Drive Modes	0x6502	UDINT	0x000003AD	-	-	-	RO

15.3.11 Index Related Parameters

communication address		parameter name	parameter No.	Variable Format	Default Value	Min	Max	Unit	Accessibili ty
decimal	hexadecimal								
12288	0x3000	Control Mode	0x3000	UINT	0	0	9	-	RW
12289	0x3001	Coordinate Select	0x3001	UINT	0	0	1	-	RW
12290	0x3002	Baud Rate Select	0x3002	UINT	0	0	4	-	RW
12291	0x3003	Pulse Input Logic Select	0x3003	UINT	0	0	5	-	RW

12292	0x3004	Pulse Input Filter Select	0x3004	UINT	0	0	4	-	RW
12293	0x3005	PCLEAR Mode Select	0x3005	UINT	0	0	2	-	RW
12294	0x3006	Encoder Output Pulse	0x3006	UDINT	10000	0	2147483647	-	RW
12296	0x3008	Encoder Output Mode	0x3007	UINT	0	0	1	-	RW
12297	0x3009	Start Index Number(0~63)	0x3008	UINT	0	0	64	-	RW
12298	0x300A	Index Buffer Mode	0x3009	UINT	0	0	1	-	RW
12544	0x3100	Index00	0x3100	-	-	-	-	-	RW
12562	0x3112	Index01	0x3101	-	-	-	-	-	RW
12580	0x3124	Index02	0x3102	-	-	-	-	-	RW
12598	0x3136	Index03	0x3103	-	-	-	-	-	RW
12616	0x3148	Index04	0x3104	-	-	-	-	-	RW
12634	0x315A	Index05	0x3105	-	-	-	-	-	RW
12652	0x316C	Index06	0x3106	-	-	-	-	-	RW
12670	0x317E	Index07	0x3107	-	-	-	-	-	RW
12688	0x3190	Index08	0x3108	-	-	-	-	-	RW
12706	0x31A2	Index09	0x3109	-	-	-	-	-	RW
12724	0x31B4	Index10	0x310A	-	-	-	-	-	RW
12742	0x31C6	Index11	0x310B	-	-	-	-	-	RW
12760	0x31D8	Index12	0x310C	-	-	-	-	-	RW
12778	0x31EA	Index13	0x310D	-	-	-	-	-	RW
12796	0x31FC	Index14	0x310E	-	-	-	-	-	RW
12814	0x320E	Index15	0x310F	-	-	-	-	-	RW
12832	0x3220	Index16	0x3110	-	-	-	-	-	RW
12850	0x3232	Index17	0x3111	-	-	-	-	-	RW
12868	0x3244	Index18	0x3112	-	-	-	-	-	RW
12886	0x3256	Index19	0x3113	-	-	-	-	-	RW
12904	0x3268	Index20	0x3114	-	-	-	-	-	RW
12922	0x327A	Index21	0x3115	-	-	-	-	-	RW
12940	0x328C	Index22	0x3116	-	-	-	-	-	RW
12958	0x329E	Index23	0x3117	-	-	-	-	-	RW
12976	0x32B0	Index24	0x3118	-	-	-	-	-	RW
12994	0x32C2	Index25	0x3119	-	-	-	-	-	RW
13012	0x32D4	Index26	0x311A	-	-	-	-	-	RW
13030	0x32E6	Index27	0x311B	-	-	-	-	-	RW
13048	0x32F8	Index28	0x311C	-	-	-	-	-	RW
13066	0x330A	Index29	0x311D	-	-	-	-	-	RW
13084	0x331C	Index30	0x311E	-	-	-	-	-	RW
13102	0x332E	Index31	0x311F	-	-	-	-	-	RW
13120	0x3340	Index32	0x3120	-	-	-	-	-	RW

13138	0x3352	Index33	0x3121	-	-	-	-	-	RW
13156	0x3364	Index34	0x3122	-	-	-	-	-	RW
13174	0x3376	Index35	0x3123	-	-	-	-	-	RW
13192	0x3388	Index36	0x3124	-	-	-	-	-	RW
13210	0x339A	Index37	0x3125	-	-	-	-	-	RW
13228	0x33AC	Index38	0x3126	-	-	-	-	-	RW
13246	0x33BE	Index39	0x3127	-	-	-	-	-	RW
13264	0x33D0	Index40	0x3128	-	-	-	-	-	RW
13282	0x33E2	Index41	0x3129	-	-	-	-	-	RW
13300	0x33F4	Index42	0x312A	-	-	-	-	-	RW
13318	0x3406	Index43	0x312B	-	-	-	-	-	RW
13336	0x3418	Index44	0x312C	-	-	-	-	-	RW
13354	0x342A	Index45	0x312D	-	-	-	-	-	RW
13372	0x343C	Index46	0x312E	-	-	-	-	-	RW
13390	0x344E	Index47	0x312F	-	-	-	-	-	RW
13408	0x3471	Index48	0x3130	-	-	-	-	-	RW
13426	0x3472	Index49	0x3131	-	-	-	-	-	RW
13444	0x3484	Index50	0x3132	-	-	-	-	-	RW
13462	0x3496	Index51	0x3133	-	-	-	-	-	RW
13480	0x34A8	Index52	0x3134	-	-	-	-	-	RW
13498	0x34BA	Index53	0x3135	-	-	-	-	-	RW
13516	0x34CC	Index54	0x3136	-	-	-	-	-	RW
13534	0x34DE	Index55	0x3137	-	-	-	-	-	RW
13552	0x34F0	Index56	0x3138	-	-	-	-	-	RW
13570	0x3502	Index57	0x3139	-	-	-	-	-	RW
13588	0x3514	Index58	0x313A	-	-	-	-	-	RW
13606	0x3526	Index59	0x313B	-	-	-	-	-	RW
13624	0x3538	Index60	0x313C	-	-	-	-	-	RW
13642	0x354A	Index61	0x313D	-	-	-	-	-	RW
13660	0x355C	Index62	0x313E	-	-	-	-	-	RW
13678	0x356E	Index63	0x313F	-	-	-	-	-	RW

15.3.11.1.1 Index00 ~Index63 Internal Variable Communication Address

Index00~Index63 has various internal variables such as IndexType, Distance, Speed, Acceleration, Deceleration, RegDistance, RegSpeed, RepeatCount, DwellTime, Next Index, Action. Internalcommunications addresses have numbers increased from the Indexcommunication address

communication address		parameter name	Variable	Min	Max	Unit	Accessibility
decimal	hexadecimal		Format				

Index	Index	Number of entries	UINT16	-	-	-	RW
Index+1	Index+0x01	IndexType	UINT16	0	10	-	RW
Index+2	Index+0x02	Distance	INT32	-2147483648	2147483647	UU	RW
Index+4	Index+0x04	Velocity	INT32	1	2147483647	UU/s	RW
Index+6	Index+0x06	Acceleration	INT32	1	2147483647	UU/s ²	RW
Index+8	Index+0x08	Deceleration	INT32	1	2147483647	UU/s ²	RW
Index+10	Index+0x0A	RegDistance	INT32	-2147483648	2147483647	UU	RW
Index+12	Index+0x0C	RegVelocity	INT32	1	2147483647	UU/s ²	RW
Index+14	Index+0x0E	RepeatCount	UINT16	1	65535	-	RW
Index+15	Index+0x0F	DwellTime	UINT16	0	65535	ms	RW
Index+16	Index+0x10	Next Index	UINT16	0	63	-	RW
Index+17	Index+0x11	Action	UINT16	0	2	-	RW

Example) Internal variables of Index00

communication address		parameter name	Variable Format	Min	Max	Unit	Accessibility
decimal	hexadecimal						
12544	0x3100	Number of entries	UINT16	-	-	-	RW
12545	0x3101	IndexType	UINT16	0	10	-	RW
12546	0x3102	Distance	INT32	-2147483648	2147483647	UU	RW
12548	0x3104	Velocity	INT32	1	2147483647	UU/s	RW
12550	0x3106	Acceleration	INT32	1	2147483647	UU/s ²	RW
12552	0x3108	Deceleration	INT32	1	2147483647	UU/s ²	RW
12554	0x310A	RegDistance	INT32	-2147483648	2147483647	UU	RW
12556	0x310C	RegVelocity	INT32	1	2147483647	UU/s ²	RW
12558	0x310E	RepeatCount	UINT16	1	65535	-	RW
12559	0x310F	DwellTime	UINT16	0	65535	ms	RW
12560	0x3110	Next Index	UINT16	0	63	-	RW
12561	0x3111	Action	UINT16	0	2	-	RW

16. Product Features

16.1 Servo Motor

■Product Features

Servomotortype name (APM-□□□□)		SAR3A	SAR5A	SA01A	SA015A		
Applied Drive (L7□A□□)		L7□A001			L7□A002		
Rated Power	[kW]	0.03	0.05	0.10	0.15		
	[N·m]	0.10	0.16	0.32	0.48		
Rated Torque	[kgf·cm]	0.97	1.62	3.25	4.87		
	[N·m]	0.29	0.48	0.96	1.43		
Instantaneous max torque	[kgf·cm]	2.92	4.87	9.74	14.62		
	[N·m]						
Rated rotational speed	[r/min]	3000					
Peak rotational speed	[r/min]	5000					
Inertia moment	[kg·m ² ×10 ⁻⁴]	0.0164	0.02	0.05	0.06		
	[gf·cm·s ²]	0.0167	0.02	0.05	0.07		
Permissible Load Inertia		30 times the motor inertia			20 times		
Rated Power Rate	[kW/s]	5.56	10.55	23.78	35.34		
Speed, Position Detector	Standard	Quad. Type Incremental 2048[P/R]					
	Option	Serial Type(to be supported)					
Specifications and Features	Protection Method	Total Enclosure-Natural Cooling IP55(except for shaft penetration)					
	Time Rating	Continuous					
	Ambient Temperature	0~40[°C]					
	Ambient Humidity	20~80[%]RH (no condensation)					
	Environment	No direct sunlight, no corrosive or inflammable gas.					
	Vibration Resistance	Vibration acceleration 49[m/s ²](5G)					
Weight	[kg]	0.3	0.4	0.5	0.7		

◆ Rotational speed-Torque Characteristics ◆

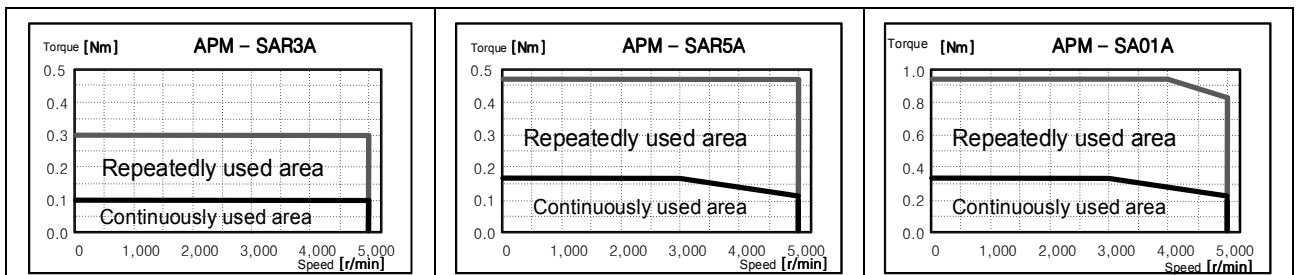

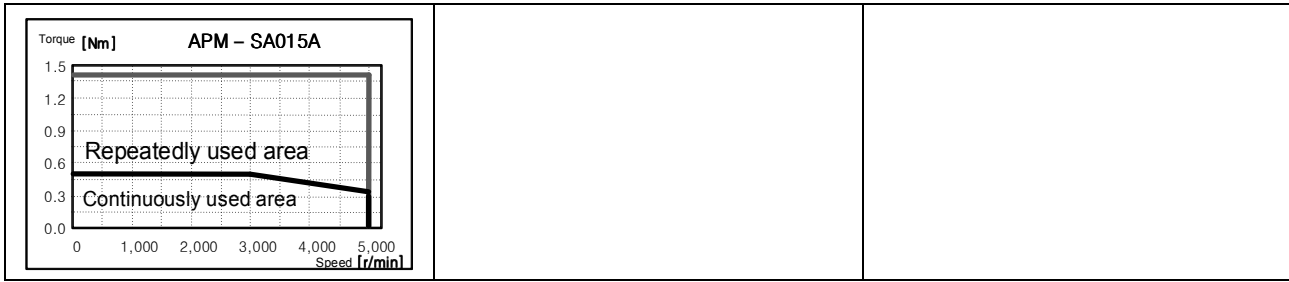

■ Product Features

Servo Motor Type Name (APM-□□□□□)		SB01A	SB02A	SB04A	SBN01A	SBN02A	SBN04A
Applied Drive (L7□A□□)		L7□A002		L7□A004	L7□A002		L7□A004
Rated Power	[kW]	0.10	0.20	0.40	0.1	0.2	0.4
Rated Torque	[N·m]	0.32	0.64	1.27	0.32	0.64	1.27
	[kgf·cm]	3.25	6.49	12.99	3.25	6.49	12.99
Instantaneous Max torque	[N·m]	0.96	1.91	3.82	0.95	1.91	3.82
	[kgf·cm]	9.74	19.48	38.96	9.74	19.48	38.96
Rated Rotational speed	[r/min]	3000					
Peak Rotational speed	[r/min]	5000					
Inertia Moment	[kg·m ² ×10 ⁻⁴]	0.11	0.18	0.32	0.11	0.18	0.32
	[gf·cm·s ²]	0.12	0.19	0.33	0.12	0.19	0.33
Permissible Load Inertia		20 times the motor inertia					
Rated Power Rate	[kW/s]	8.89	22.26	50.49	8.91	22.22	50.41
Speed Position Detector	Standard	Quad. Type Incremental 3000[P/R]					
	Option	Serial Type 19[Bit]					
Specifications and Features	Protection Method	Total Enclosure-Natural Cooling IP65(except for shaft penetration)					

	Time Rating	Continuous					
	Ambient Temperature	0~40[°C]					
	Ambient Humidity	20~80[%]RH (no condensation)					
	Environment	No direct sunlight, no corrosive or inflammable gas.					
	Vibration Resistance	Vibration acceleration 49[m/s ²](5G)					
Weight	[kg]	0.8	1.1	1.6	0.8	1.1	1.6

◆ Rotational speed-Torque Characteristics ◆

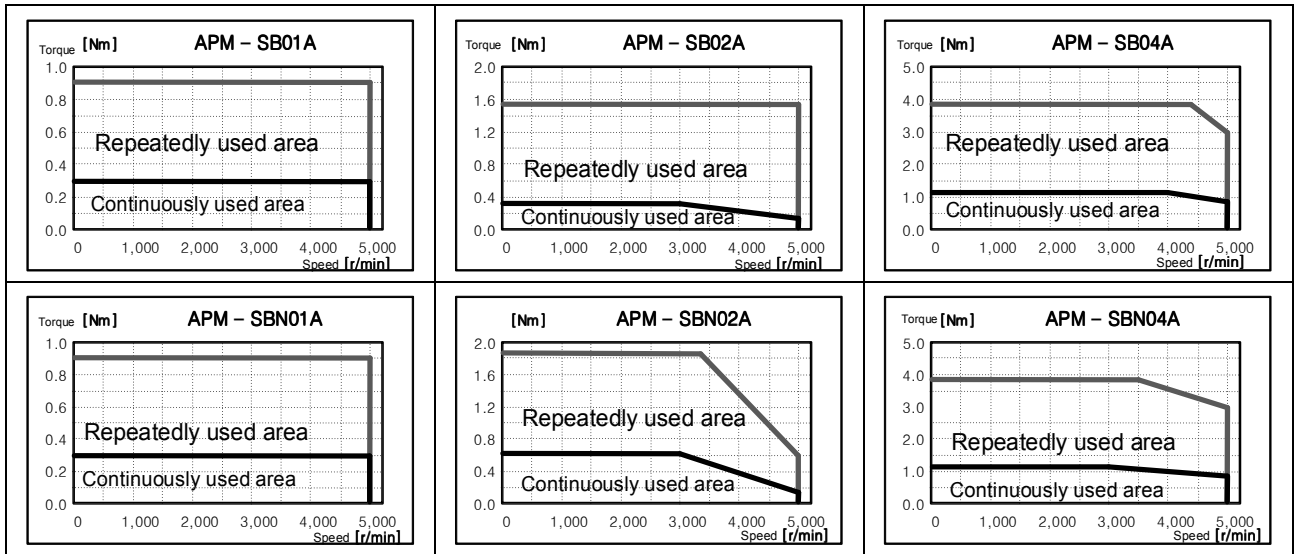

■ Product Features

Servo Motor Type Name (APM-□□□□□)		SBN04A-BK	SC04A	SC06A	SC08A	SC10A		
Applied Drive (L7□A□□)		L7□A004		L7□A008		L7□A010		
Rated Power	[kW]	0.4	0.4	0.6	0.8	1.0		
Rated Torque	[N·m]	1.27	1.27	1.91	2.55	3.19		
	[kgf·cm]	12.99	12.99	19.49	25.98	32.48		
Instantaneous Max torque	[N·m]	3.82	3.82	5.73	7.64	9.56		
	[kgf·cm]	38.96	38.96	58.47	77.95	97.43		
Rated Rotational speed	[r/min]	3000						
Peak Rotational speed	[r/min]	5000						
Inertia Moment	[kg·m ² ×10 ⁻⁴]	0.25	0.67	1.09	1.51	1.93		
	[gf·cm·s ²]	0.26	0.69	1.11	1.54	1.97		
Permissible Load Inertia		20 times	15 times the motor inertia					
Rated Power Rate	[kW/s]	63.84	24.05	33.39	43.02	52.57		
Speed Position	Standard	Quadrature Type Incremental 3000[P/R]						

Detector	Option	Serial Type 19[bit]					
Specifications and Features	Protection Method	Total Enclosure-Natural Cooling IP65(except for shaft penetration)					
	Time Rating	Continuous					
	Ambient Temperature	0~40[°C]					
	Ambient Humidity	20~80[%]RH (no condensation)					
	Environment	No direct sunlight, no corrosive or inflammable gas.					
	Vibration Resistance	Vibration acceleration 49[m/s ²](5G)					
Weight	[kg]	1.6	1.9	2.5	3.2	3.8	

◆ Rotational speed-Torque Characteristics ◆

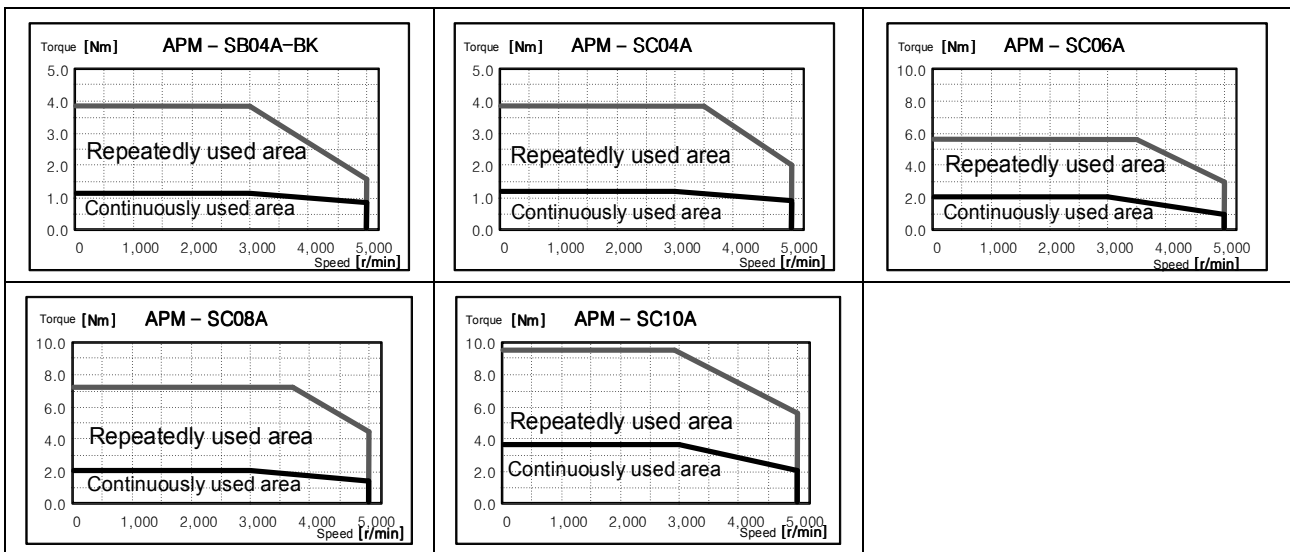

■ Product Features

Servo Motor Type Name (APM-□□□□□)		SC03D	SC05D	SC06D	SC07D		
Applied Drive (L7□A□□)		L7□A004		L7□A008			
Rated Power	[kW]	0.30	0.45	0.55	0.65		
Rated Torque	[N·m]	1.43	2.15	2.63	3.10		
	[kgf·cm]	14.61	21.92	26.79	31.66		
Instantaneous Max torque	[N·m]	4.30	6.45	7.88	9.31		
	[kgf·cm]	43.84	65.77	80.38	94.99		
Rated Rotational speed	[r/min]	2000					
Peak Rotational speed	[r/min]	3000					
Inertia Moment	[kg·m ² ×10 ⁻⁴]	0.67	1.09	1.51	1.93		
	[gf·cm·s ²]	0.69	1.11	1.54	1.97		
Permissible Load Inertia		15 times the motor inertia					

Rated Power Rate	[kW/s]	30.43	42.27	45.69	49.97		
Speed Position Detector	Standard	Quadrature Type Incremental 3000[P/R]					
	Option	Serial Type 19[bit]					
Specifications and Features	Protection Method	Total Enclosure-Natural Cooling IP65(except for shaft penetration)					
	Time Rating	Continuous					
	Ambient Temperature	0~40[°C]					
	Ambient Humidity	20~80[%]RH (no condensation)					
	Environment	No direct sunlight, no corrosive or inflammable gas.					
	Vibration Resistance	Vibration acceleration 49[m/s ²](5G)					
Weight	[kg]	1.9	2.5	3.2	3.9		

◆ Rotational speed-Torque Characteristics ◆

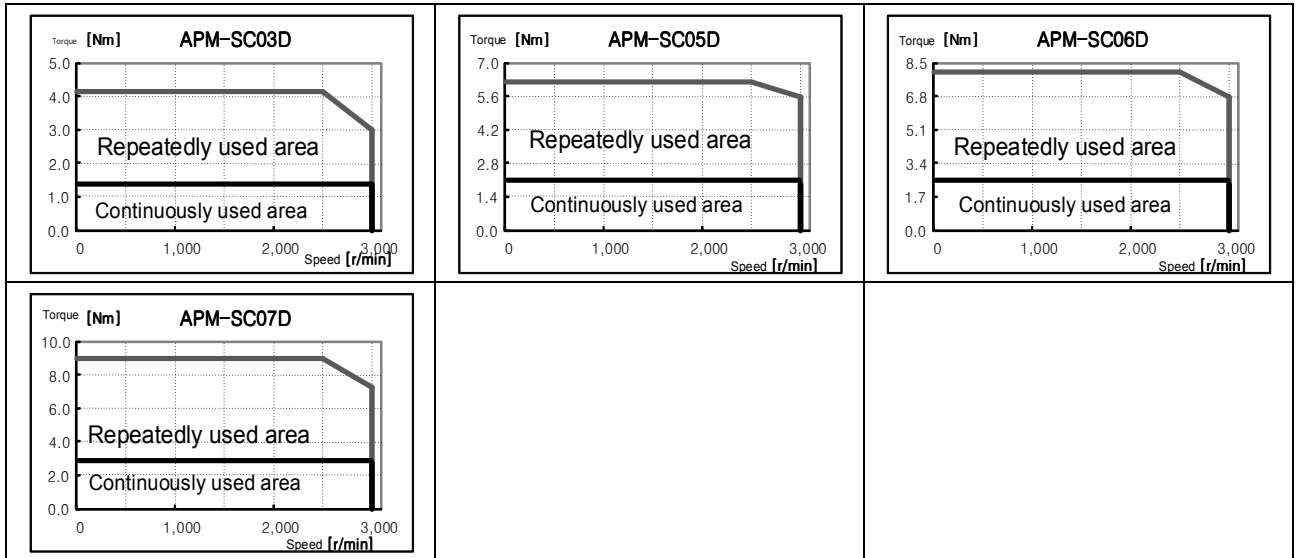

■ Product Features

Servo Motor Type Name (APM-□□□□□)		SE09A	SE15A	SE22A	SE30A	SE06D	SE11D	
Applied Drive (L7□A□□)		L7□A010	L7□A020		L7□A035	L7□A008	L7□A010	
Rated Power	[kW]	0.9	1.5	2.2	3.0	0.6	1.1	
	[N·m]	2.86	4.77	7.00	9.55	2.86	5.25	
Rated Torque	[kgf·cm]	29.23	48.72	71.45	97.43	29.23	53.59	
	[N·m]	8.59	14.32	21.01	28.64	8.59	15.75	
Instantaneous Max torque	[kgf·cm]	87.69	146.15	214.35	292.29	87.69	160.76	
	[r/min]	3000				2000		
Peak Rotational speed	[r/min]	5000				3000		

Inertia Moment	[kg·m ² ×10 ⁻⁴]	6.66	12.00	17.34	22.68	6.66	12.00
	[gf·cm·s ²]	6.80	12.24	17.69	23.14	6.80	12.24
Permissible Load Inertia		10 times the motor inertia					
Rated Power Rate	[kW/s]	12.32	18.99	28.28	40.20	12.32	22.98
Speed Position Detector	Standard	Quadrature Type Incremental 3000[P/R]					
	Option	Serial Type 19[bit]					
Specifications and Features	Protection Method	Total Enclosure-Natural Cooling IP65(except for shaft penetration)					
	Time Rating	Continuous					
	Ambient Temperature	0~40[°C]					
	Ambient Humidity	20~80[%]RH(no condensation)					
	Environment	No direct sunlight, no corrosive or inflammable gas.					
	Vibration Resistance	Vibration acceleration 49[m/s ²](5G)					
Weight	[kg]	5.5	7.5	9.7	11.8	5.5	7.5

◆ Rotational speed-Torque Characteristics ◆

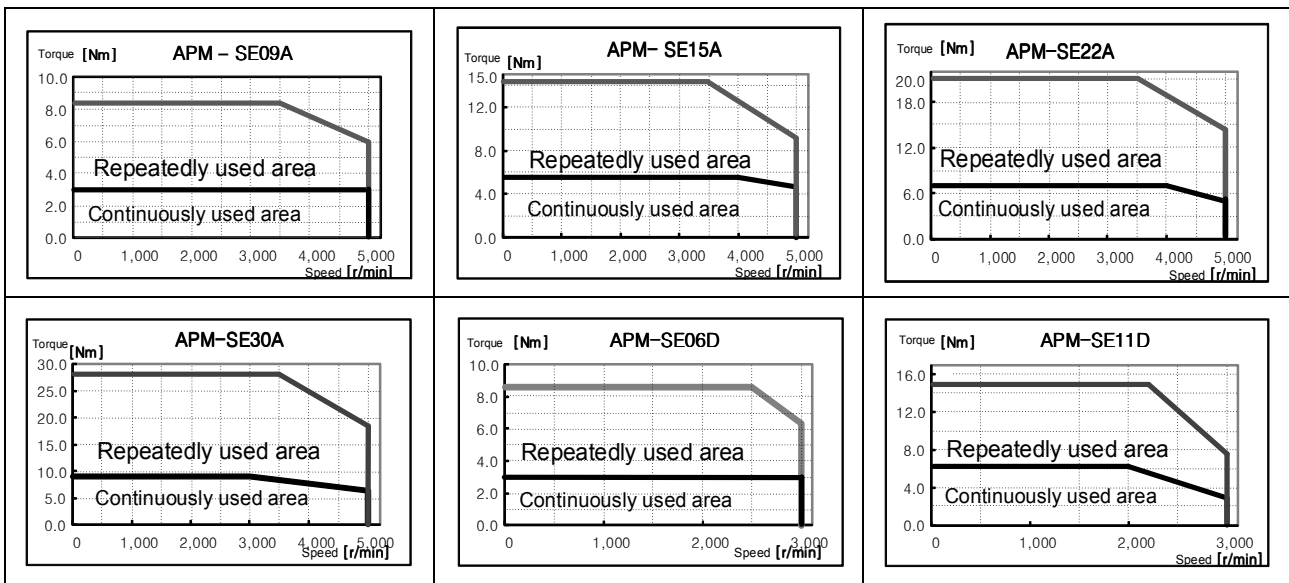

■ Product Features

Servo Motor Type Name (APM-□□□□□)		SE16D	SE22D	SE03M	SE06M	SE09M	SE12M
Applied Drive (L7□A□□)		L7□A020		L7□A004	L7□A008	L7□A010	L7□A020
Rated Power	[kW]	1.6	2.2	0.3	0.6	0.9	1.2
Rated Torque	[N·m]	7.64	10.50	2.86	5.73	8.59	11.46
	[kgf·cm]	77.94	107.17	29.23	58.46	87.69	116.92
Instantaneous Max torque	[N·m]	22.92	31.51	8.59	17.19	25.78	34.37
	[kgf·cm]	233.83	321.52	87.69	175.30	263.06	350.75

Rated Rotational speed	[r/min]	2000		1000			
Peak Rotational speed	[r/min]	3000		2000			
Inertia Moment	[kg·m ² ×10 ⁻⁴]	17.34	22.68	6.66	12.00	17.34	22.68
	[gf·cm·s ²]	17.69	23.14	6.80	12.24	17.69	23.14
Permissible Load Inertia		10 times the motor inertia					
Rated Power Rate	[kW/s]	33.65	48.64	12.32	27.35	42.59	57.89
Speed Position Detector	Standard	Quadrature Type Incremental 3000[P/R]					
	Option	Serial Type 19[bit]					
Specifications and Features	Protection Method	Total Enclosure-Natural Cooling IP65(except for shaft penetration)					
	Time Rating	Continuous					
	Ambient Temperature	0~40[°C]					
	Ambient Humidity	20~80[%]RH(no condensation)					
	Environment	No direct sunlight, no corrosive or inflammable gas.					
	Vibration Resistance	Vibration acceleration 49[m/s ²](5G)					
Weight	[kg]	9.7	11.8	5.5	7.5	9.7	11.8

◆ Rotational speed-Torque Characteristics ◆

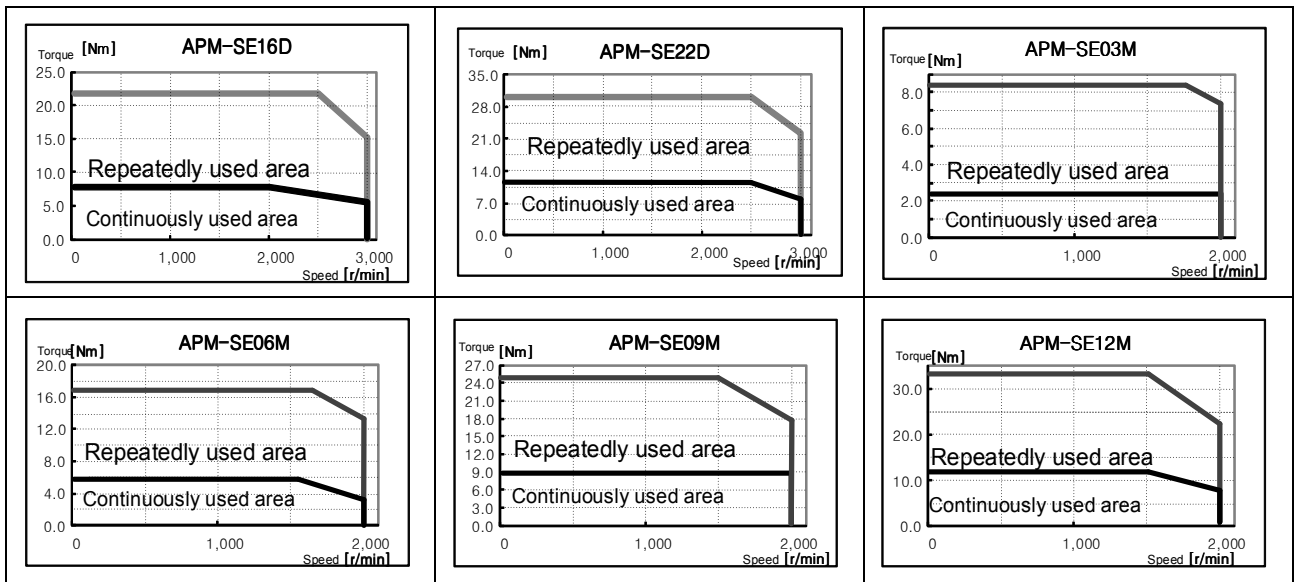

■ Product Features

Servo Motor Type Name (APM-□□□□)	SE05G	SE09G	SE13G	SE17G	SF30A	SF50A	
Applied Drive (L7□A□□)	L7□A008	L7□A010	L7□A020		L7□A035	L7□A050	
Rated Power	[kW]	0.45	0.85	1.3	1.7	3.0	5.0
Rated Torque	[N·m]	2.86	5.41	8.28	10.82	9.55	15.91

	[kgf·cm]	29.23	55.21	84.44	110.42	97.43	162.38
Instantaneous Max torque	[N·m]	8.59	16.23	24.83	32.46	28.64	47.74
	[kgf·cm]	87.69	165.63	253.32	331.26	292.29	487.15
Rated Rotational speed	[r/min]	1500				3000	
Peak Rotational speed	[r/min]	3000				5000	
Inertia Moment	[kg·m ² ×10 ⁻⁴]	6.66	12.00	17.34	22.68	30.74	52.13
	[gf·cm·s ²]	6.80	12.24	17.69	23.14	31.37	53.19
Permissible Load Inertia		10 times the motor inertia				5 times the motor inertia	
Rated Power Rate	[kW/s]	12.32	24.40	39.49	51.63	29.66	48.58
Speed Position Detector	Standard	Quadrature Type Incremental 3000[P/R]					
	Option	Serial Type 19[bit]					
Specifications and Features	Protection Method	Total Enclosure-Natural Cooling IP65(except for shaft penetration)					
	Time Rating	Continuous					
	Ambient Temperature	0~40[°C]					
	Ambient Humidity	20~80[%]RH(no condensation)					
	Environment	No direct sunlight, no corrosive or inflammable gas.					
	Vibration Resistance	Vibration acceleration 49[m/s ²](5G)					
Weight	[kg]	5.5	7.5	9.7	11.8	12.4	17.7

◆ Rotational speed-Torque Characteristics ◆

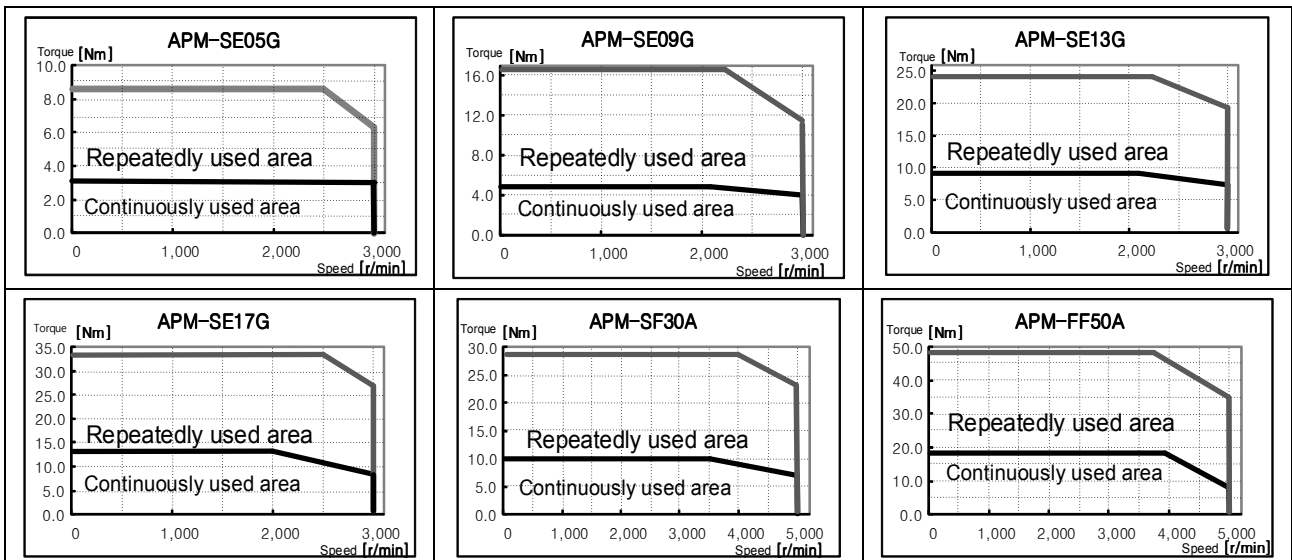

■ Product Features

Servo Motor Type Name (APM-□□□□□)		SF22D	LF35D	SF55D	SF20G	LF30G	SF44G
Applied Drive (L7□A□□)		L7□A020	L7□A035	L7□A050	L7□A035		L7□A050
Rated Power	[kW]	2.2	3.5	5.5	1.8	2.9	4.4
	[N·m]	10.50	16.71	26.26	11.46	18.46	28.01
Rated Torque	[kgf·cm]	107.17	170.50	267.93	116.92	188.37	285.80
	[N·m]	31.51	50.13	78.77	34.37	55.38	84.02
Instantaneous Max torque	[kgf·cm]	321.52	511.51	803.80	350.75	565.10	857.39
	[N·m]						
Rated Rotational speed	[r/min]	2000			1500		
Peak Rotational speed	[r/min]	3000			3000	2700	3000
Inertia Moment	[kg·m ² ×10 ⁻⁴]	30.74	52.13	85.31	30.74	52.13	83.60
	[gf·cm·s ²]	31.35	53.16	83.60	31.37	53.19	85.31
Permissible Load Inertia		5 times the motor inertia					
Rated Power Rate	[kW/s]	35.88	53.56	82.47	42.71	65.37	93.83
Speed Position Detector	Standard	Quadrature Type Incremental 3000[P/R]					
	Option	Serial Type 19[bit]					
Specifications and Features	Protection Method	Total Enclosure-Natural Cooling IP65(except for shaft penetration)					
	Time Rating	Continuous					
	Ambient Temperature	0~40[°C]					
	Ambient Humidity	20~80[%]RH(no condensation)					
	Environment	No direct sunlight, no corrosive or inflammable gas.					
	Vibration Resistance	Vibration acceleration 49[m/s ²](5G)					
Weight	[kg]	12.4	17.7	26.3	12.4	17.7	26.3

◆ Rotational speed-Torque Characteristics ◆

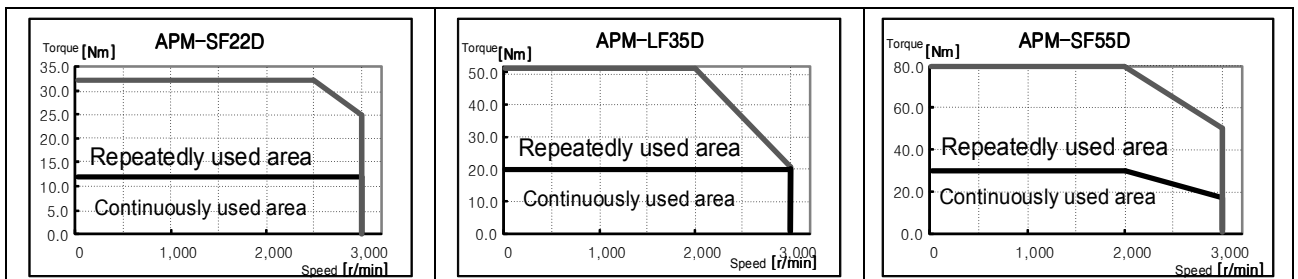

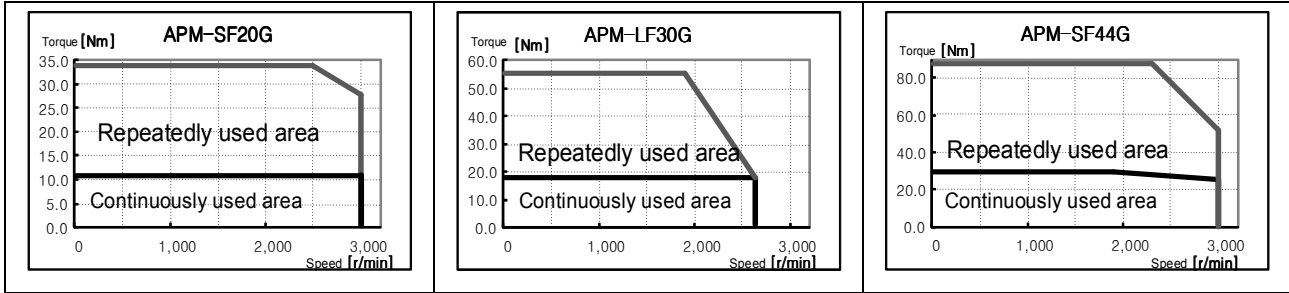

Product Features

Servo Motor Type Name (APM-□□□□)		SF12M	SF20M	LF30M	SF44M		
Applied Drive (L7□A□□)		L7□A020	L7□A035		L7□A050		
Rated Power	[kW]	1.2	2.0	3.0	4.4		
Rated Torque	[N·m]	11.46	19.10	28.64	42.01		
	[kgf·cm]	116.92	194.86	292.29	428.69		
Instantaneous Max torque	[N·m]	34.37	57.29	85.93	126.04		
	[kgf·cm]	350.75	584.58	876.88	1286.08		
Rated Rotational speed	[r/min]	1000					
Peak Rotational speed	[r/min]	2000		1700	2000		
Inertia Moment	[kg·m ² ×10 ⁻⁴]	30.74	52.13	83.60	121.35		
	[gf·cm·s ²]	31.37	53.19	85.31	123.83		
Permissible Load Inertia		5 times the motor inertia					
Rated Power Rate	[kW/s]	42.71	69.95	98.15	145.45		
Speed Position Detector	Standard	Quadrature Type Incremental 3000[P/R]					
	Option	Serial Type 19[bit]					
Specifications and Features	Protection Method	Total Enclosure-Natural Cooling IP65(except for shaft penetration)					
	Time Rating	Continuous					
	Ambient Temperature	0~40[°C]					
	Ambient Humidity	20~80[%]RH(no condensation)					
	Environment	No direct sunlight, no corrosive or inflammable gas.					
	Vibration Resistance	Vibration acceleration 49[m/s ²](5G)					
Weight	[kg]	12.4	17.7	26.3	35.6		

◆ Rotational speed-Torque Characteristics ◆

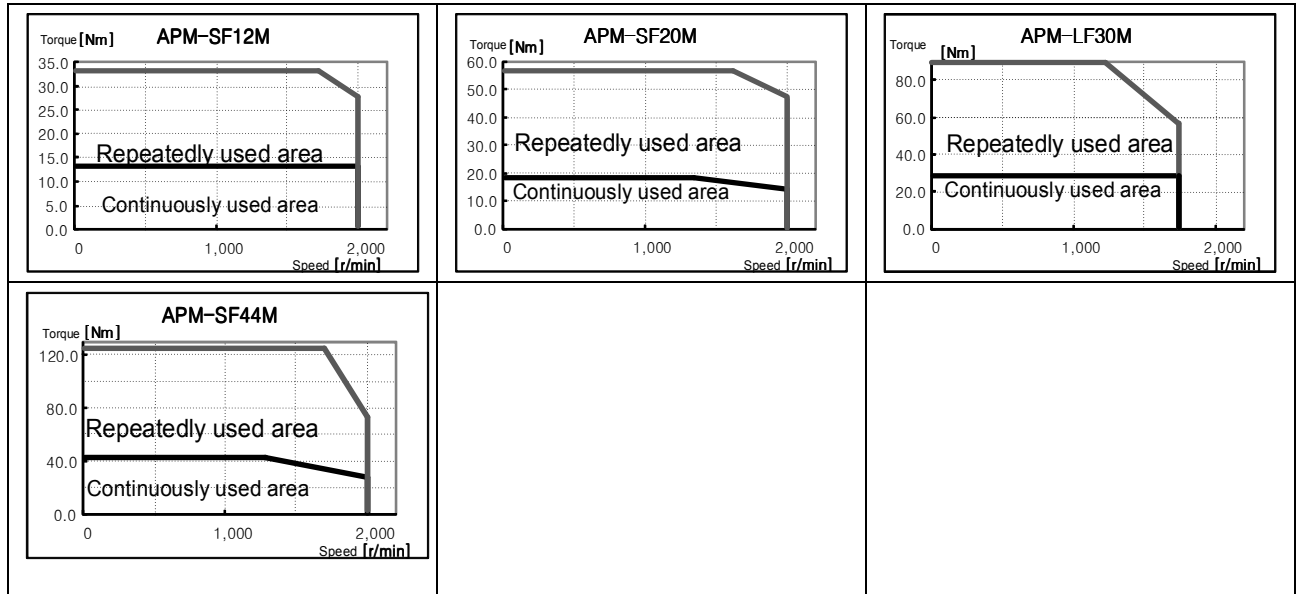

■ Product Features

Servo Motor Type Name (APM-□□□□)		SG20G	LG30G	SG44G	SG22D	LG35D	SG55D
Applied Drive (L7□A□□)		L7□A020	L7□A035	L7□A050	L7□A020	L7□A035	L7□A050
Rated Power	[kW]	1.8	2.9	4.4	2.2	3.5	5.5
	[N·m]	11.46	18.46	28.01	10.50	16.71	26.26
Rated Torque	[kgf·cm]	116.92	188.37	285.80	107.20	170.52	267.9
	[N·m]	34.47	55.38	84.02	31.51	50.13	78.77
Instantaneous Max torque	[kgf·cm]	350.80	565.10	857.39	321.52	511.51	803.8
	[r/min]	1500			2000		
Peak Rotational speed	[r/min]	3000	2700	3000	3000		
Inertia Moment	[kg·m ² ×10 ⁻⁴]	51.42	80.35	132.41	51.42	80.35	135.11
	[gf·cm·s ²]	52.47	81.99	135.11	52.47	81.99	132.41
Permissible Load Inertia		5 times the motor inertia					
Rated Power Rate	[kW/s]	25.53	42.41	59.24	21.45	34.75	52.07
Speed Position Detector	Standard	Quadrature Type Incremental 3000[P/R]					
	Option	Serial Type 19[bit]					
Specifications and Features	Protection Method	Total Enclosure-Natural Cooling IP65(except for shaft penetration)					
	Time Rating	Continuous					
	Ambient Temperature	0~40[°C]					
	Ambient Humidity	20~80[%]RH(no condensation)					
	Environment	No direct sunlight, no corrosive or inflammable gas.					

	Vibration Resistance	Vibration acceleration 49[m/s ²](5G)					
Weight	[kg]	17.0	22.0	30.8	17.0	22.0	30.8

◆ Rotational speed-Torque Characteristics ◆

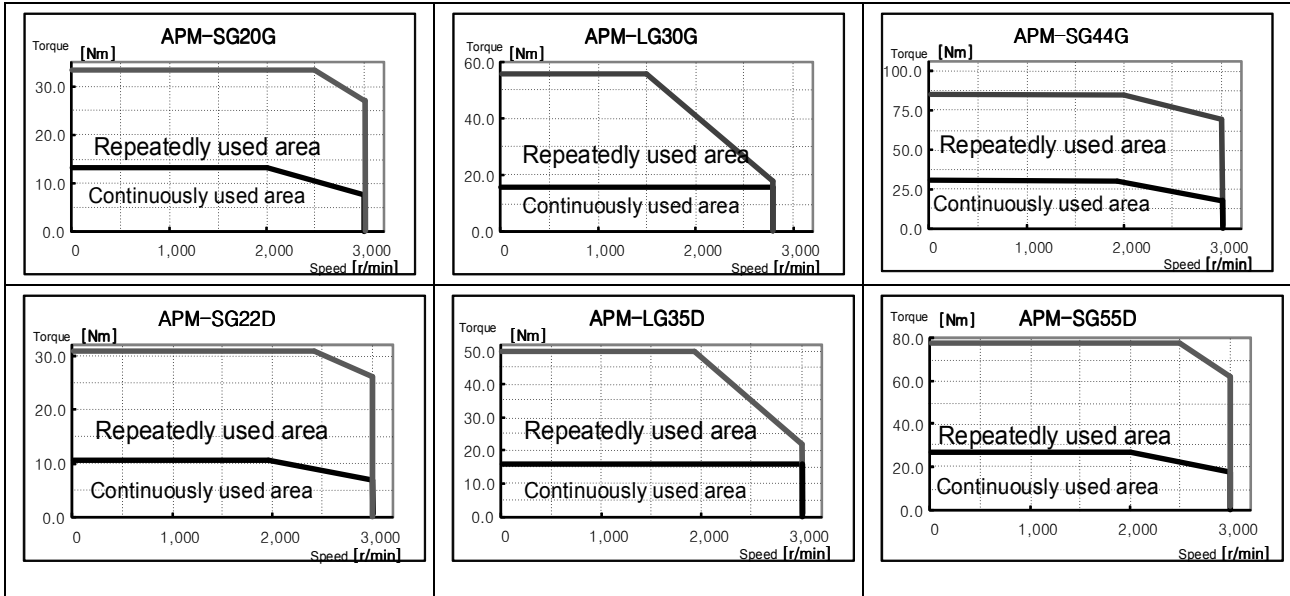

■ Product Features

Servo Motor Type Name (APM-□□□□□)		SG12M	SG20M	LG30M	SG44M			
Applied Drive (L7□A□□)		L7□A020	L7□A035		L7□A050			
Rated Power	[kW]	1.2	2.0	3.0	4.4			
Rated Torque	[N·m]	11.46	19.10	28.64	42.01			
	[kgf·cm]	116.92	194.86	292.29	428.69			
Instantaneous Max torque	[N·m]	34.37	57.29	85.93	126.04			
	[kgf·cm]	350.75	584.58	876.88	1286.08			
Rated Rotational speed	[r/min]	1000						
Peak Rotational speed	[r/min]	2000		1700	2000			
Inertia Moment	[kg·m ² ×10 ⁻⁴]	51.42	80.35	132.41	172.91			
	[gf·cm·s ²]	52.47	81.99	135.11	176.44			
Permissible Load Inertia		5 times the motor inertia						
Rated Power Rate	[kW/s]	25.53	45.39	61.97	102.08			
Speed Position Detector	Standard	Quadrature Type Incremental 3000[P/R]						
	Option	Serial Type 19[bit]						
Specifications and Features	Protection Method	Total Enclosure-Natural Cooling IP65(except for shaft penetration)						
	Time Rating	Continuous						

	Ambient Temperature	0~40[°C]					
	Ambient Humidity	20~80[%]RH(no condensation)					
	Environment	No direct sunlight, no corrosive or inflammable gas.					
	Vibration Resistance	Vibration acceleration 49[m/s ²](5G)					
Weight	[kg]	17.0	22.0	30.8	37.5		

◆ Rotational speed-Torque Characteristics ◆

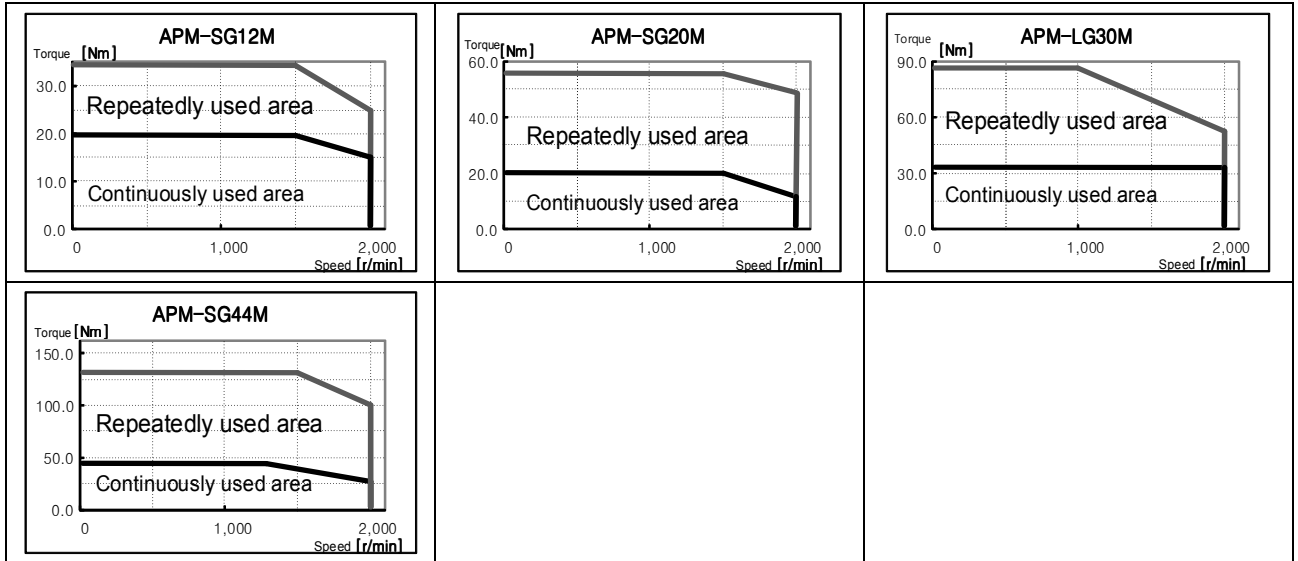

■ Product Features

Servo Motor Type Name (APM-□□□□□)		HB01A	HB02A	HB04A	HE09A	HE15A	
Applied Drive (L7□A□□)		L7□A002		L7□A004	L7□A010	L7□A020	
Rated Power	[kW]	0.1	0.2	0.4	0.9	1.5	
Rated Torque	[N·m]	0.32	0.64	1.27	2.86	4.77	
	[kgf·cm]	3.25	6.49	12.99	29.23	48.72	
Instantaneous Max torque	[N·m]	0.96	1.91	3.82	8.59	14.32	
	[kgf·cm]	9.74	19.48	38.96	87.69	146.15	
Rated Rotational speed	[r/min]	3000					
Peak Rotational speed	[r/min]	3500					
Inertia Moment	[kg·m ² ×10 ⁻⁴]	0.27	0.33	0.46	19.56	22.27	
	[gf·cm·s ²]	0.27	0.34	0.47	19.96	22.72	
Permissible Load Inertia		20 times the motor inertia			10 times the motor inertia		
Rated Power Rate	[kW/s]	3.34	11.98	34.47	4.10	10.01	
Speed Position	Standard	Quadrature Type Incremental 1024P/R			2048 P/R		

Detector	Option	x					
Specifications and Features	Protection Method	Total Enclosure-Natural Cooling IP55(except for shaft penetration)					
	Time Rating	Continuous					
	Ambient Temperature	0~40°C					
	Ambient Humidity	20~80[%]RH(no condensation)					
	Environment	No direct sunlight, no corrosive or inflammable gas.					
	Vibration Resistance	Vibration acceleration 49m/s ² (5G)					
Weight	[kg]	0.9	1.2	1.7	5.8	7.4	

◆ Rotational speed-Torque Characteristics ◆

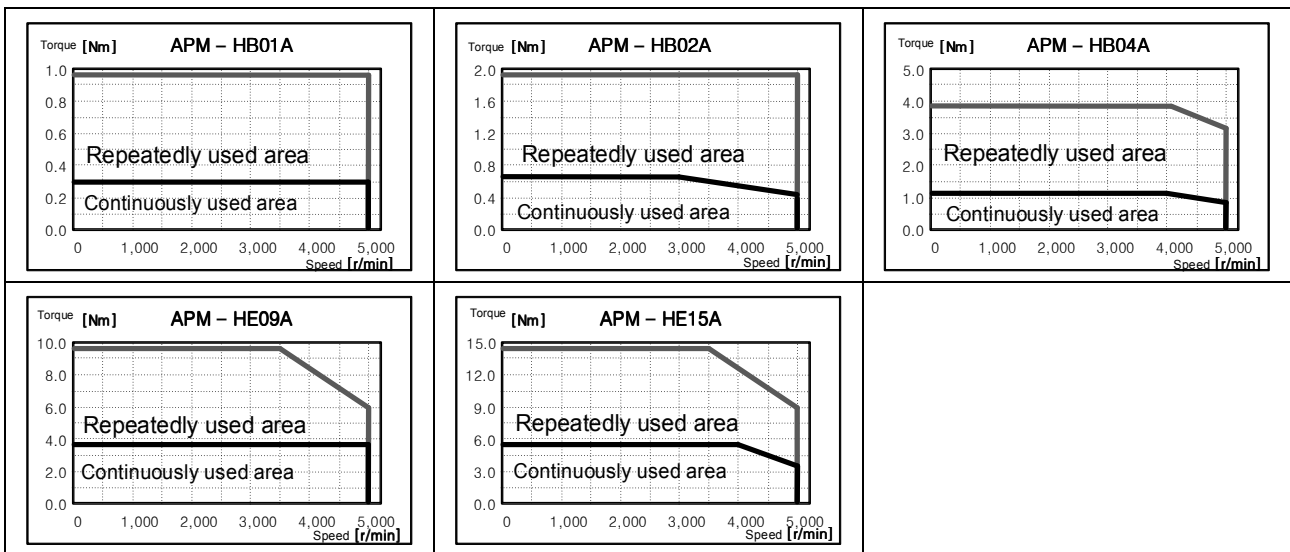

■ Product Features

Servo Motor Type Name (APM-□□□□□)		FB01A	FB02A	FB04A	FC04A	FC06A	
Applied Drive (L7□A□□)		L7□A001	L7□A002	L7□A004		L7□A008	
Rated Power	[kW]	0.10	0.20	0.40	0.40	0.60	
Rated Torque	[N·m]	0.32	0.64	1.27	1.27	1.91	
	[kgf·cm]	3.25	6.50	12.99	13.00	19.50	
Instantaneous Max torque	[N·m]	0.96	1.91	3.82	3.82	5.73	
	[kgf·cm]	9.74	19.49	38.98	38.98	58.47	
Rated Rotational speed	[r/min]	3000					
Peak Rotational speed	[r/min]	5000					
Inertia Moment	[kg·m ² ×10 ⁻⁴]	0.09	0.15	0.25	0.50	0.88	
	[gf·cm·s ²]	0.09	0.15	0.25	0.51	0.89	
Permissible Load Inertia		20 times the motor inertia			15 times the motor inertia		

Rated Power Rate	[kW/s]	11.38	27.95	65.90	32.62	41.69	
Speed Position Detector	Standard	Serial Type 19[bit]					
	Option	X					
Specifications and Features	Protection Method	Total Enclosure-Natural Cooling IP65(except for shaft penetration)					
	Time Rating	Continuous					
	Ambient Temperature	0~40[°C]					
	Ambient Humidity	20~80[%]RH(no condensation)					
	Environment	No direct sunlight, no corrosive or inflammable gas.					
	Vibration Resistance	Vibration acceleration 49[m/s ²](5G)					
Weight	[kg]	0.7	0.9	1.3	1.6	2.2	

◆ Rotational speed-Torque Characteristics ◆

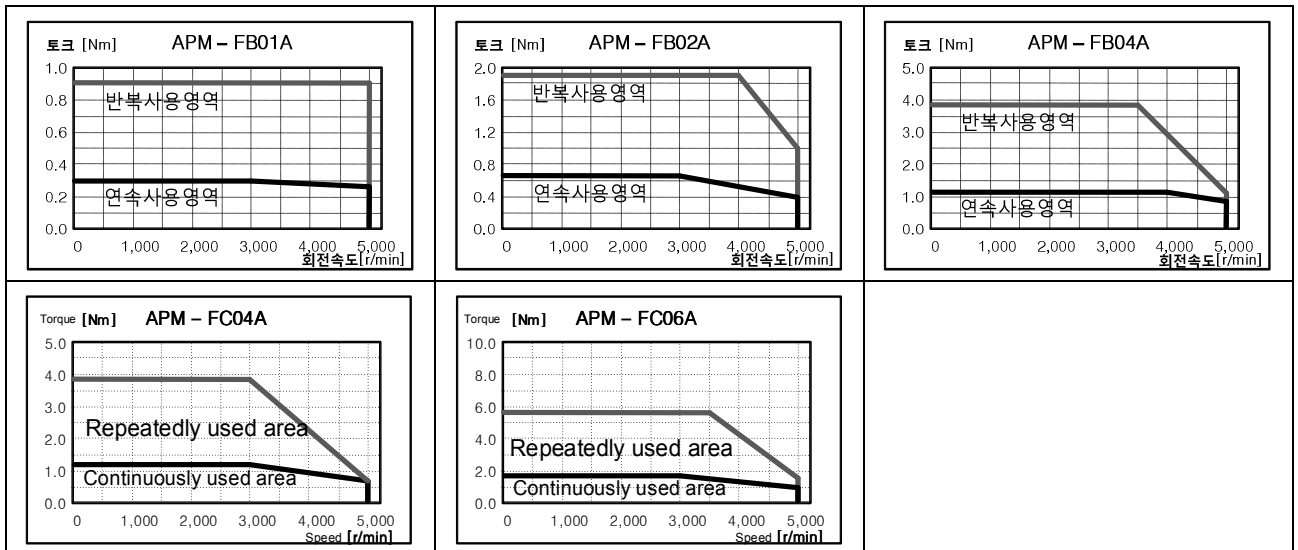

■ Product Features

Servo Motor Type Name (APM-□□□□)		FC08A	FC10A	FC03D	FC05D	FC06D	FC07D
Applied Drive (L7□A□□)		L7□A008	L7□A010	L7□A004	L7□A008		
Rated Power	[kW]	0.75	1.00	0.30	0.45	0.55	0.65
Rated Torque	[N·m]	2.39	3.18	1.43	2.15	2.60	3.10
	[kgf·cm]	24.36	32.50	14.60	21.90	26.80	31.70
Instantaneous Max torque	[N·m]	7.16	9.55	4.30	6.45	7.88	9.31
	[kgf·cm]	73.08	97.44	43.80	65.80	80.40	95.00
Rated Rotational speed	[r/min]	3000			2000		
Peak Rotational speed	[r/min]	5000	4500	3000			

Inertia Moment	[kg·m ² ×10 ⁻⁴]	1.25	1.62	0.50	0.88	1.25	1.62
	[gf·cm·s ²]	1.27	1.65	0.51	0.89	1.27	1.65
Permissible Load Inertia		15 times the motor inertia					
Rated Power Rate	[kW/s]	45.78	62.74	41.28	52.76	55.39	59.64
Speed Position Detector	Standard	Serial Type 19[bit]					
	Option	X					
Specifications and Features	Protection Method	Total Enclosure-Natural Cooling IP65(except for shaft penetration)					
	Time Rating	Continuous					
	Ambient Temperature	0~40[°C]					
	Ambient Humidity	20~80[%]RH(no condensation)					
	Environment	No direct sunlight, no corrosive or inflammable gas.					
	Vibration Resistance	Vibration acceleration 49[m/s ²](5G)					
Weight	[kg]	2.7	3.8	1.6	2.2	2.7	3.8

◆ Rotational speed-Torque Characteristics ◆

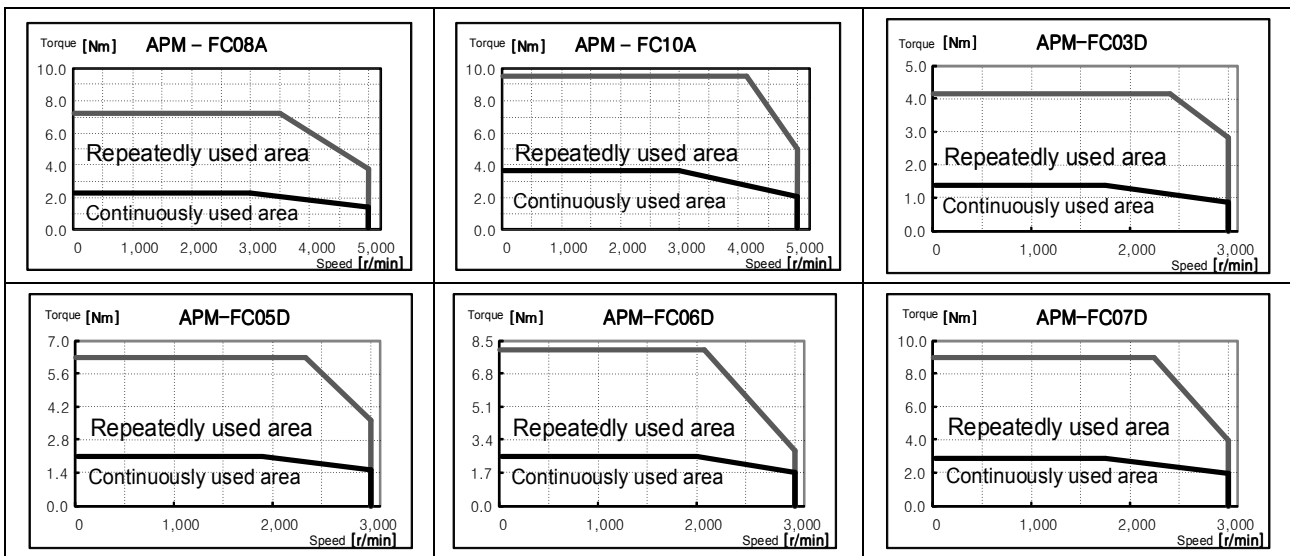

■ Product Features

Servo Motor Type Name (APM-□□□□□)		FE09A	FE15A	FE22A	FE30A	FE06D	FE11D
Applied Drive (L7□A□□)		L7□A010	L7□A020	L7□A035	L7□A035	L7□A008	L7□A010
Rated Power	[kW]	0.9	1.5	2.2	3.0	0.6	1.1
Rated Torque	[N·m]	2.86	4.77	7.00	9.55	2.86	5.25
	[kgf·cm]	29.20	48.70	71.40	97.40	29.20	53.60
Instantaneous Max torque	[N·m]	8.59	14.32	21.01	28.65	8.59	15.75
	[kgf·cm]	87.70	146.10	214.30	292.20	87.70	160.70

Rated Rotational speed	[r/min]	3000				2000	
Peak Rotational speed	[r/min]	5000				3000	
Inertia Moment	[kg·m ² ×10 ⁻⁴]	5.66	10.18	14.62	19.04	5.66	10.18
	[gf·cm·s ²]	5.77	10.39	14.92	19.43	5.77	10.39
Permissible Load Inertia		10 times the motor inertia					
Rated Power Rate	[kW/s]	14.47	22.38	33.59	47.85	14.49	27.08
Speed Position Detector	Standard	Serial Type 19 [bit]					
	Option	X					
Specifications and Features	Protection Method	Total Enclosure-Natural Cooling IP65(except for shaft penetration)					
	Time Rating	Continuous					
	Ambient Temperature	Workable Temperature : 0~40[°C]					
	Ambient Humidity	20~80[%]RH(no condensation)					
	Environment	No direct sunlight, no corrosive or inflammable gas.					
	Vibration Resistance	Vibration acceleration 49[m/s ²](5G)					
Weight	[kg]	5.0	6.7	8.5	10.1	5.0	6.7

◆ Rotational speed-Torque Characteristics ◆

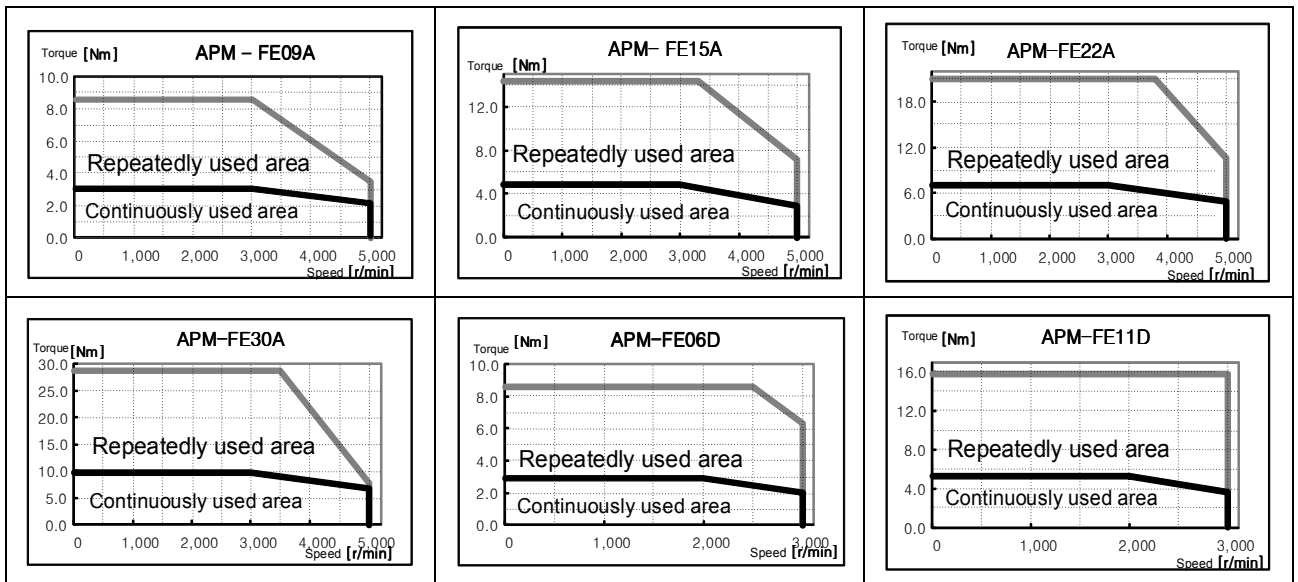

■ Product Features

Servo Motor Type Name (APM-□□□□□)		FE16D	FE22D	FE03M	FE06M	FE09M	FE12M
Applied Drive (L7□A□□)		L7□A020	L7□A035	L7□A004	L7□A008	L7□A010	L7□A020
Rated Power	[kW]	1.6	2.2	0.3	0.6	0.9	1.2
Rated Torque	[N·m]	7.63	10.5	2.86	5.72	8.59	11.46

	[kgf·cm]	77.90	107.10	29.22	58.4	87.7	116.9
Instantaneous Max torque	[N·m]	22.92	31.51	8.59	17.18	25.77	34.22
	[kgf·cm]	233.80	321.40	87.66	175.3	262.9	349.1
Rated Rotational speed	[r/min]	2000		1000			
Peak Rotational speed	[r/min]	3000		2000			
Inertia Moment	[kg·m ² ×10 ⁻⁴]	14.62	19.04	5.66	10.18	14.62	19.04
	[gf·cm·s ²]	14.92	19.43	5.77	10.39	14.92	19.43
Permissible Load Inertia		10 times the motor inertia					
Rated Power Rate	[kW/s]	39.89	57.90	14.49	32.22	50.48	68.91
Speed Position Detector	Standard	Serial Type 19 [bit]					
	Option	X					
Specifications and Features	Protection Method	Total Enclosure-Natural Cooling IP65(except for shaft penetration)					
	Time Rating	Continuous					
	Ambient Temperature	Workable Temperature : 0~40[°C]					
	Ambient Humidity	20~80[%]RH(no condensation)					
	Environment	No direct sunlight, no corrosive or inflammable gas.					
	Vibration Resistance	Vibration acceleration 49[m/s ²](5G)					
Weight	[kg]	8.5	10.1	5.0	6.7	8.5	10.1

◆ Rotational speed-Torque Characteristics ◆

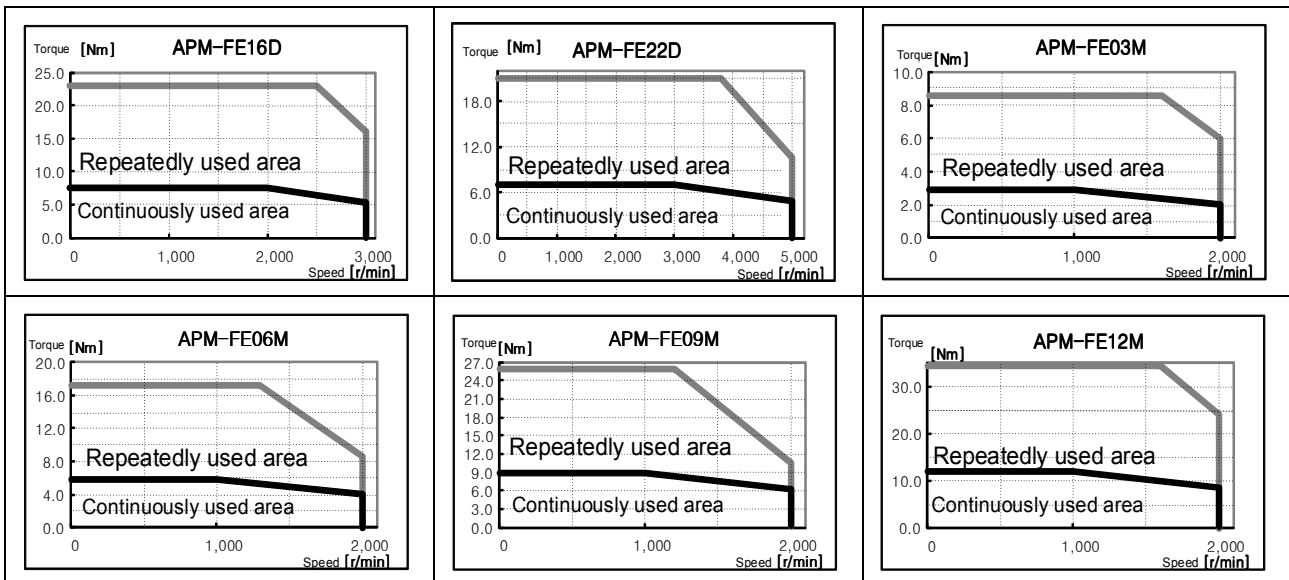

■ Product Features

Servo Motor Type Name (APM-□□□□)	FE05G	FE09G	FE13G	FE17G	FF30A	FF50A
----------------------------------	-------	-------	-------	-------	-------	-------

Applied Drive (L7□A□□)		L7□A008	L7□A010	L7□A020		L7□A035	L7□A050
Rated Power	[kW]	0.45	0.85	1.3	1.7	3.0	5.0
Rated Torque	[N·m]	2.86	5.41	8.27	10.82	9.55	15.91
	[kgf·cm]	29.22	55.19	84.41	110.38	97.40	162.30
Instantaneous Max torque	[N·m]	8.59	16.23	24.82	32.46	28.65	47.74
	[kgf·cm]	87.66	165.57	253.23	331.14	292.3	487.00
Rated Rotational speed	[r/min]	1500				3000	
Peak Rotational speed	[r/min]	3000				5000	
Inertia Moment	[kg·m ² ×10 ⁻⁴]	5.66	10.18	14.62	19.04	27.96	46.56
	[gf·cm·s ²]	5.77	10.39	14.92	19.43	28.53	47.51
Permissible Load Inertia		10 times the motor inertia				5 times the motor inertia	
Rated Power Rate	[kW/s]	14.49	28.74	46.81	61.46	32.59	54.33
Speed Position Detector	Standard	Serial Type 19 [bit]					
	Option	X					
Specifications and Features	Protection Method	Total Enclosure-Natural Cooling IP65(except for shaft penetration)					
	Time Rating	Continuous					
	Ambient Temperature	Workable Temperature : 0~40[°C]					
	Ambient Humidity	20~80[%]RH(no condensation)					
	Environment	No direct sunlight, no corrosive or inflammable gas.					
	Vibration Resistance	Vibration acceleration 49[m/s ²](5G)					
Weight	[kg]	5.0	6.7	8.5	10.1	12.5	17.4

◆ Rotational speed-Torque Characteristics ◆

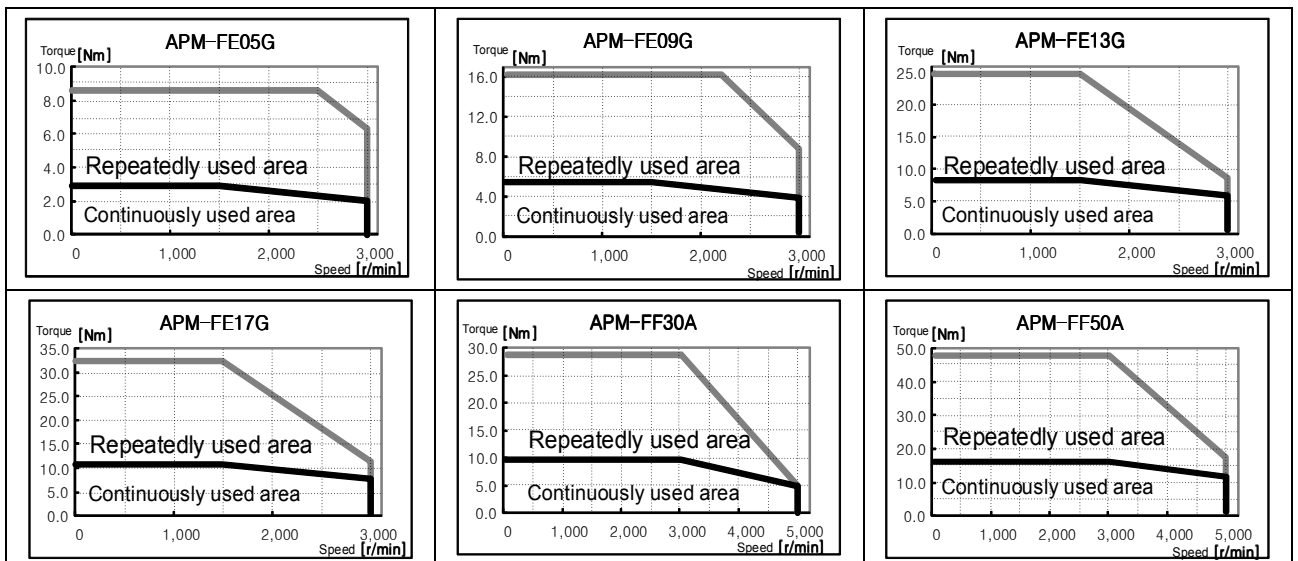

■ Product Features

Servo Motor Type Name (APM-□□□□□)		FF22D	FF35D	FF55D	FF20G	FF30G	FF44G
Applied Drive (L7□A□□)		L7□A020	L7□A035	L7□A050	L7□A020	L7□A035	L7□A050
Rated Power	[kW]	2.2	3.5	5.5	1.8	2.9	4.4
	[N·m]	10.50	16.70	26.25	11.45	18.46	28.00
Rated Torque	[kgf·cm]	107.1	170.4	267.8	116.9	188.3	285.7
	[N·m]	31.50	50.10	78.76	34.35	55.38	84.03
Instantaneous Max torque	[kgf·cm]	321.30	511.40	803.4	350.60	564.90	857.10
	[r/min]	2000			1500		
Peak Rotational speed	[r/min]	3000			3000	2700	3000
Inertia Moment	[kg·m ² ×10 ⁻⁴]	27.96	46.56	73.85	27.96	46.56	73.85
	[gf·cm·s ²]	28.53	47.51	75.36	28.53	47.51	75.36
Permissible Load Inertia		5 times the motor inertia					
Rated Power Rate	[kW/s]	39.43	59.89	93.27	46.92	73.14	106.15
Speed Position Detector	Standard	Serial Type 19 [bit]					
	Option	X					
Specifications and Features	Protection Method	Total Enclosure-Natural Cooling IP65(except for shaft penetration)					
	Time Rating	Continuous					
	Ambient Temperature	Workable Temperature : 0~40[°C]					
	Ambient Humidity	20~80[%]RH(no condensation)					
	Environment	No direct sunlight, no corrosive or inflammable gas.					
	Vibration Resistance	Vibration acceleration 49[m/s ²](5G)					
Weight	[kg]	12.5	17.4	25.12	12.5	17.4	25.2

◆ Rotational speed-Torque Characteristics ◆

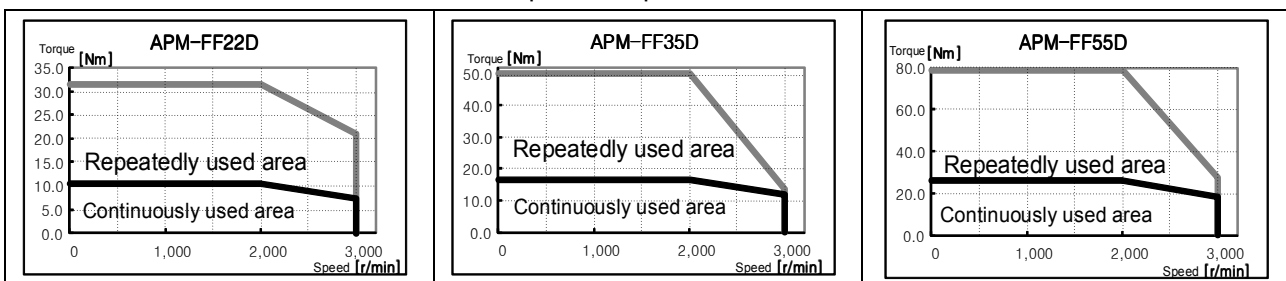

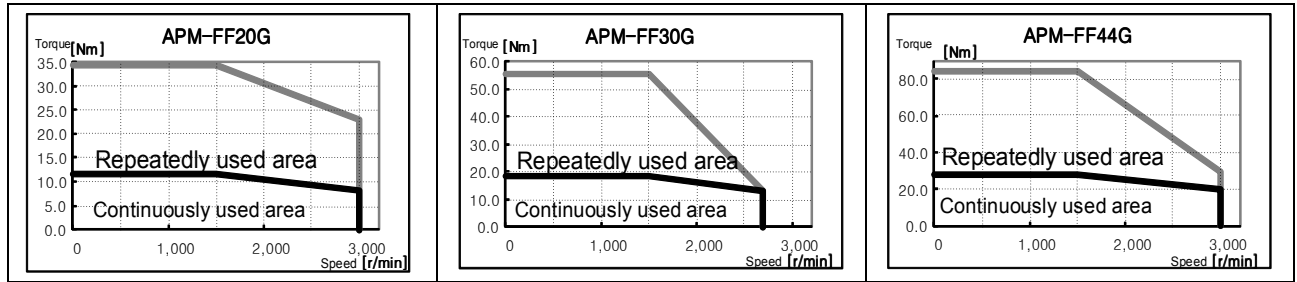

■ Product Features

Servo Motor Type Name (APM-□□□□)		FF12M	FF20M	FF30M	FF44M		
Applied Drive (L7□A□□)		L7□A020	L7□A020	L7□A035	L7□A050		
Rated Power	[kW]	1.2	2.0	3.0	4.4		
	[N·m]	11.46	19.09	28.64	42.02		
Rated Torque	[kgf·cm]	116.9	194.8	292.2	428.7		
	[N·m]	34.38	57.29	85.94	126.1		
Instantaneous Max torque	[kgf·cm]	350.70	584.40	876.60	128.60		
	[N·m]						
Rated Rotational speed	[r/min]	1000					
Peak Rotational speed	[r/min]	2000		1700	2000		
Inertia Moment	[kg·m ² ×10 ⁻⁴]	27.96	46.56	73.85	106.7		
	[gf·cm·s ²]	28.53	47.51	75.36	108.9		
Permissible Load Inertia		5 times the motor inertia					
Rated Power Rate	[kW/s]	46.94	78.27	111.04	165.38		
speed, position 검출기	Standard	Serial Type 19 [bit]					
	Option	X					
Specifications and Features	Protection Method	Total Enclosure-Natural Cooling IP65(except for shaft penetration)					
	Time Rating	Continuous					
	Ambient Temperature	Workable Temperature : 0~40[°C]					
	Ambient Humidity	20~80[%]RH(no condensation)					
	Environment	No direct sunlight, no corrosive or inflammable gas.					
	Vibration Resistance	Vibration acceleration 49[m/s ²](5G)					
Weight	[kg]	12.5	17.4	25.2	33.8		

◆ Rotational speed-Torque Characteristics ◆

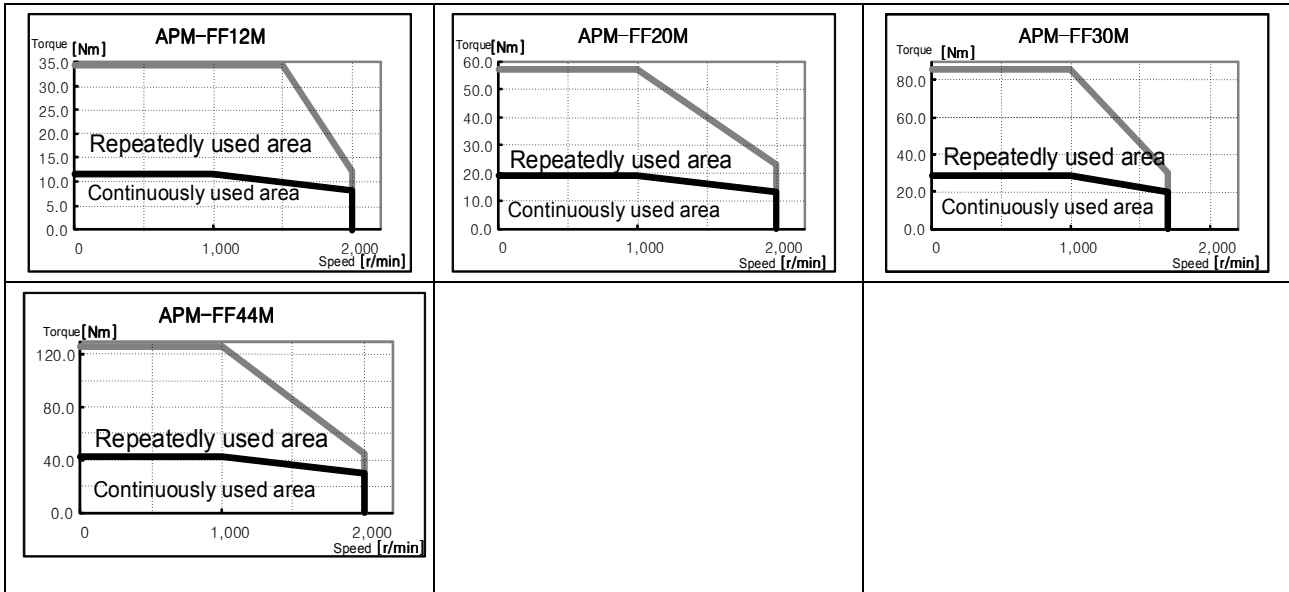

Product Features

Servo Motor Type Name (APM-□□□□□)		FG22D	FG35D	FG55D	FG20G	FG30G	FG44G
Applied Drive (L7□A□□)		L7□A020	L7□A035	L7□A050	L7□A020	L7□A035	L7□A050
Rated Power	[kW]	2.2	3.5	5.5	1.8	2.9	4.4
	[N·m]	10.50	16.71	26.25	11.50	18.50	28.00
Rated Torque	[kgf·cm]	107.1	170.4	267.8	116.9	188.4	285.8
	[N·m]	31.51	50.12	78.76	34.40	55.40	84.00
Instantaneous Max torque	[kgf·cm]	321.30	511.30	803.4	350.80	565.1	857.4
	[r/min]	2000			1500		
Rated Rotational speed	[r/min]	3000	2700	3000	3000	2700	3000
Peak Rotational speed	[kg·m ² ×10 ⁻⁴]	41.13	71.53	117.72	14.13	71.53	117.72
	[gf·cm·s ²]	41.97	72.99	120.12	41.97	72.99	120.12
Permissible Load Inertia		5 times the motor inertia					
Rated Power Rate	[kW/s]	26.78	38.99	58.51	31.91	47.66	66.64
Speed Position Detector	Standard	Serial Type 19 [bit]					
	Option	Quadrature Type Incremental 3000[P/R]					
Specifications and Features	Protection Method	Total Enclosure-Natural Cooling IP65(except for shaft penetration)					
	Time Rating	Continuous					
	Ambient Temperature	Workable Temperature : 0~40[°C]					
	Ambient Humidity	20~80[%]RH(no condensation)					
	Environment	No direct sunlight, no corrosive or inflammable gas.					

	Vibration Resistance	Vibration acceleration 49[m/s ²](5G)					
Weight	[kg]	15.4	20.2	28.12	15.4	20.2	28.0

◆ Rotational speed-Torque Characteristics ◆

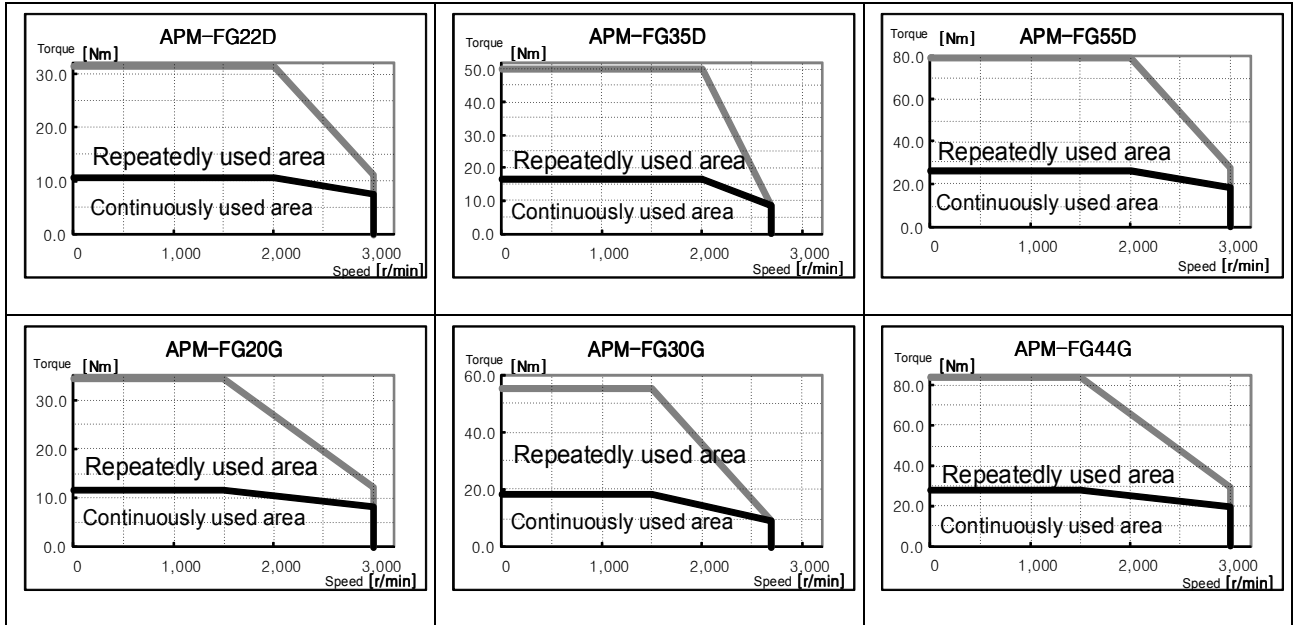

■ Product Features

Servo Motor Type Name (APM-□□□□□)		FG12M	FG20M	FG30M	FG44M		
Applied Drive (L7□A□□)		L7□A020		L7□A035	L7□A050		
Rated Power	[kW]	1.2	2.0	3.0	4.4		
Rated Torque	[N·m]	11.50	19.10	28.60	42.00		
	[kgf·cm]	116.9	194.9	292.3	428.7		
Instantaneous Max torque	[N·m]	34.40	57.30	85.90	126.00		
	[kgf·cm]	350.8	584.6	876.9	128.61		
Rated Rotational speed	[r/min]	1000					
Peak Rotational speed	[r/min]	2000		1700	2000		
Inertia Moment	[kg·m ² ×10 ⁻⁴]	41.13	71.53	117.72	149.40		
	[gf·cm·s ²]	41.97	72.99	120.12	152.45		
Permissible Load Inertia		5 times the motor inertia					
Rated Power Rate	[kW/s]	31.91	51.00	69.70	118.14		
Speed Position Detector	Standard	Serial Type 19 [bit]					
	Option	X					
Specifications and Features	Protection Method	Total Enclosure-Natural Cooling IP65(except for shaft penetration)					

	Time Rating	Continuous					
	Ambient Temperature	Workable Temperature : 0~40[°C]					
	Ambient Humidity	20~80[%]RH(no condensation)					
	Environment	No direct sunlight, no corrosive or inflammable gas.					
	Vibration Resistance	Vibration acceleration 49[m/s ²](5G)					
Weight	[kg]	15.4	20.2	28.0	33.5		

◆ Rotational speed-Torque Characteristics ◆

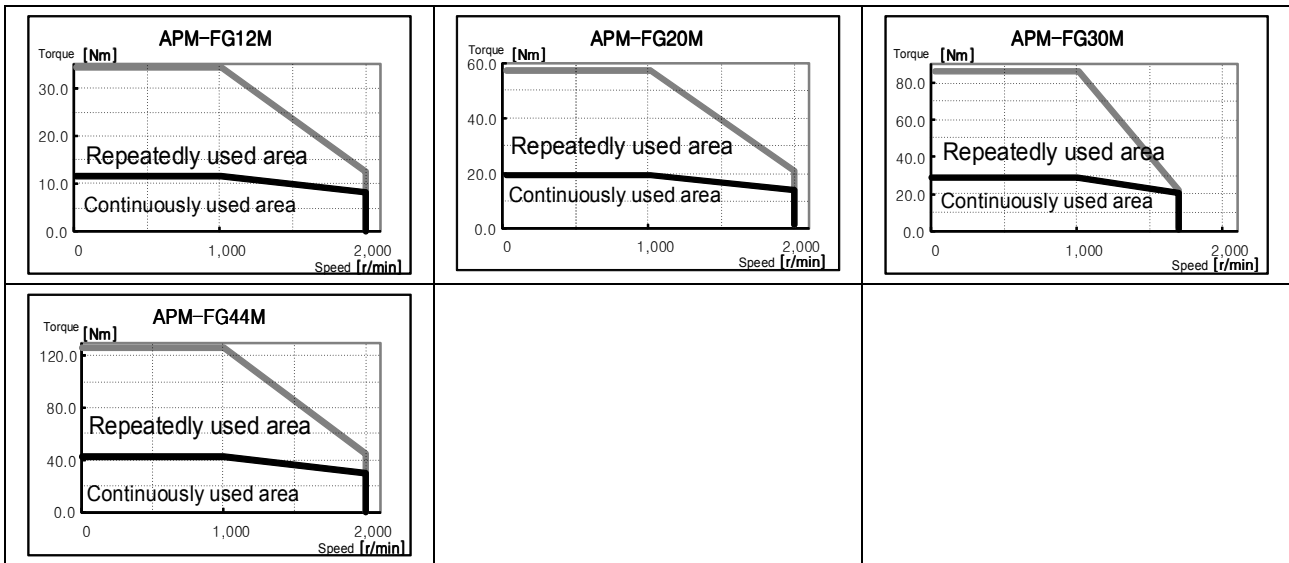

■ Electronic Brake Specifications



Applied Motor Series	APM-SA	APM-SB	APM-SC	APM-SE	APM-SF	APM-SG
Usage	Maintenance	Maintenance	Maintenance	Maintenance	Maintenance	Maintenance
Input Power [V]	DC 24V	DC 24V	DC 24V	DC 24V	DC 24V	DC 90V
Static Friction Torque [N·m]	0.32	1.47	3.23	10.4	40	74
Power [W]	6	6.5	9	19.4	25	32
Coil Resistance[Ω]	96	89	64	29.6	23	327

Rated Current [A]	0.25	0.27	0.38	0.81	1.04	0.28
Braking Method	Spring Brake	Spring Brake	Spring Brake	Spring Brake	Spring Brake	Spring Brake
Insulation Type	Type F	Type F	Type F	Type F	Type F	Type F
Applied Motor Series	APM-FB	APM-FC				
Usage	Maintenance	Maintenance				
Input Power [V]	DC 24V	DC 24V				
Static Friction Torque [N•m]	1.47	3.23				
Power [W]	6.5	9				
Coil Resistance [Ω]	89	64				
Rated Current [A]	0.27	0.38				
Braking Method	Spring Brake	Spring Brake				
Insulation Type	Type F	Type F				

Note 6) Please do not use the interface DC24V power as the electronic brake power

Please use the exclusive power for electronic brake

Note 7) The specifications of electronic brakes installed in our servo motors are the same for each series.

Note 8) Electronic brake is to be used for maintaining static status. Do not use the electronic brake for braking..

Note 9) The above characteristics were measured at 20°C.

Note 10) The specifications above are subject to change. Please make sure to check the voltage specification printed on the motor.

16.1.1 Outside View

■ SA Series | APM-SAR3A, APM-SAR5A, APM-SA01A, APM-SA015A

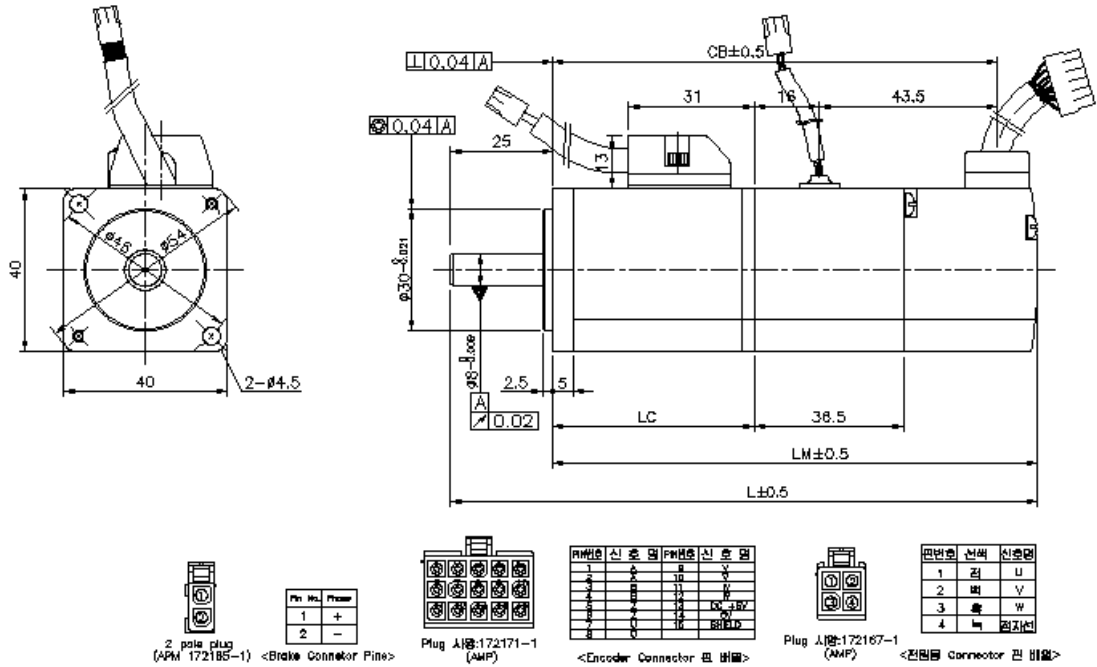

Type Name	External Dimension				Weight (kg)
	L	LM	LC	CB	
SAR3A	100(137.5)	76(112.5)	42.5	66(102.5)	0.32(0.67)
SAR5A	108(144.5)	83(119.5)	49.5	73(109.5)	0.38(0.73)
SA01A	125(161.5)	100(136.5)	66.5	90(126.5)	0.5(0.85)
SA015A	145	120	86.5	110	0.7

- Note 11) The shaft end of 40Flange is Straight.
- Note 12) Please use DC 24[V] power to open the brake.
- Note 13) Figures in () indicates dimensions of brake-attached type.(except for SA015A)

■ SB Series | APM-SB01A, APM-SB02A, APM-SB04A

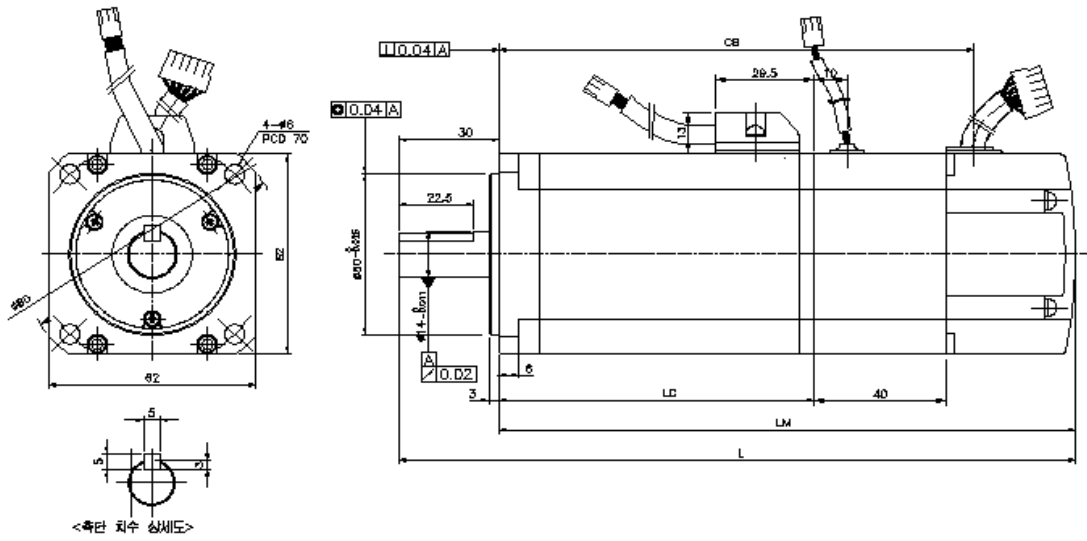

<속단 치수 상세도>

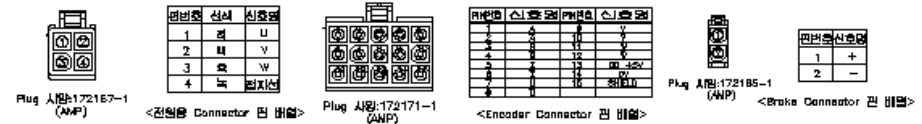

Type Name	External Dimension				Weight (kg)
	L	LM	LC	CB	
SB01A	121.5(161.5)	91.5(131.5)	52.5	61(101)	0.82(1.4)
SB02A	135.5(175.5)	105.5(145.5)	66.5	73(115)	1.08(1.66)
SB04A	163.5(203.5)	133.5(173.5)	94.5	103(143)	1.58(2.16)

Note 14) Please use DC 24[V] power to open the brake.

Note 15) Figures in () indicates dimensions of brake-attached type.

■ SC Series | APM-SC04A,SC03D, APM-SC06A,SC05D, APM-SC08A,SC06D, APM-SC10A,SC07D

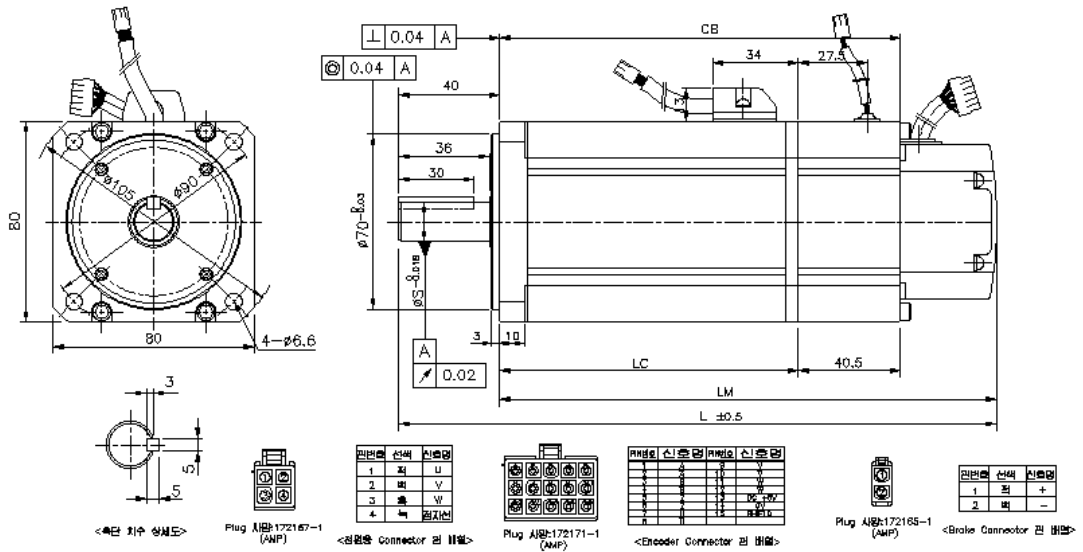

Type Name	External Dimension					Weight (kg)
	L	LM	LC	CB	S	
SC04A,SC03D	158(198.5)	118(158.5)	79	87(127.5)	14	1.88(2.92)
SC06A,SC05D	178(218.5)	138(178.5)	99	107(147.5)	16	2.52(3.56)
SC08A,SC06D	198(238.5)	158(198.5)	119	127(167.5)	16	3.15(4.22)
SC10A,SC07D	218(258.5)	178(218.5)	139	147(187.5)	16	3.80(4.94)

Note 16) Please use DC 24[V] power to open the brake.

Note 17) Figures in () indicates dimensions of brake-attached type.

■ SE Series | APM-SE09A, SE06D, SE05G, SE03M, APM-SE15A, SE11D, SE09G, SE06M, APM-SE22A, SE16D, SE13G, SE09M, APM-SE30A, SE22D, SE17G, SE12M

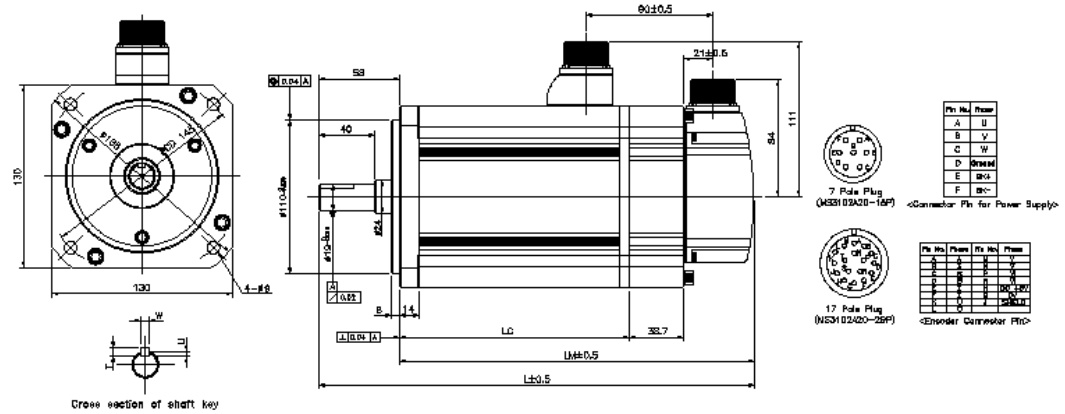

Type Name	External Dimension				Key Dimension			Weight (kg)
	L	LM	LC	S	T	W	U	
SE09A,SE06D,SE05G,SE03M	201(240)	143(182)	94	19	5	5	3	5.5(7.04)
SE15A,SE11D,SE09G,SE06M	225(264)	167(206)	118	19	5	5	3	7.54(9.08)
SE22A,SE16D,SE13G,SE09M	249(288)	191(230)	142	22	6	6	3.5	9.68(11.22)
SE30A,SE22D,SE17G,SE12M	273(312)	215(254)	166	22	6	6	3.5	11.78(13.32)

Note 18) Please use DC 24[V] power to open the brake.

Note 19) Figures in () indicates dimensions of brake-attached type.

■ SF Series | APM-SF30A, SF22D, SF20G, SF12M,
APM-SF50A, LF35D, LF30G, SF20M,
APM-LF30M, SF55D, SF44G,
APM-SF44M

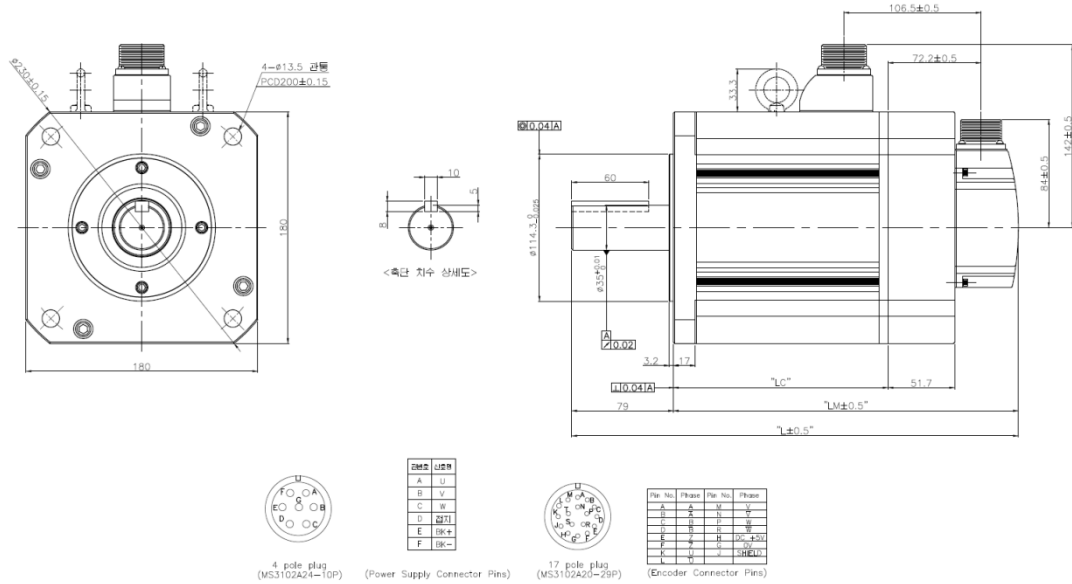

Type Name	External Dimension				Key Dimension					Weight (kg)
	L	LM	LC	LR	S	QK	T	W	U	
SF30A, SF22D, SF20G, SF12M	261.5 (312.9)	182.5 (233.9)	133 (132.7)	79	35 ^(0~+0.01)	60	8	10	5	12.4 (19.2)
SF50A, LF35D, LF30G, SF20M	295.5 (346.9)	216.5 (267.9)	167 (166.7)							17.7 (24.9)
LF30M, SF55D, SF44G	345.5 (396.9)	266.5 (317.9)	217 (216.7)							26.3 (33.4)
SF44M	405.5 (456.9)	326.5 (377.9)	277 (276.7)							35.6 (42.8)

- Note 20) Eye bolt applies only to LF30M or above.
- Note 21) Please use DC 24[V] power to open the brake.
- Note 22) Figures in () indicates dimensions of brake-attached type.

■ **APM-HB01A(Hollow Shaft Type), APM-HB02A(Hollow Shaft Type), APM-HB04A(Hollow Shaft Type)**

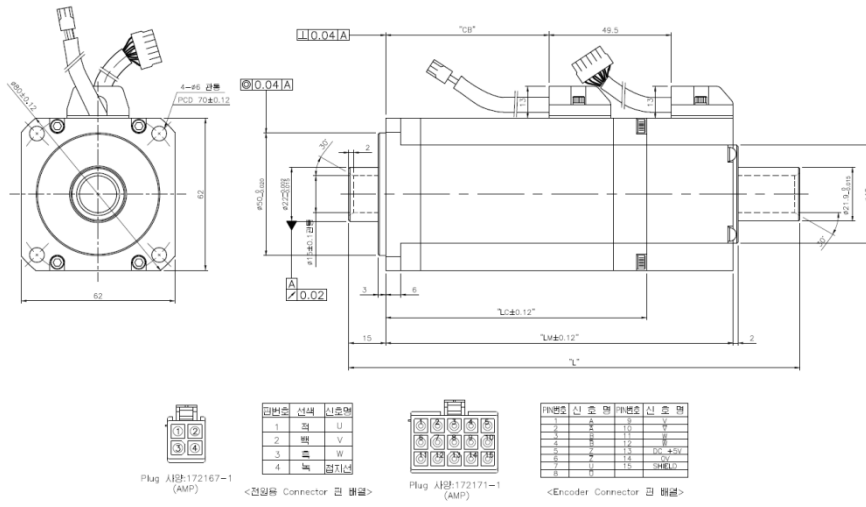

Type Name	External Dimension					Weight (Kg)
	L	LM	LC	CB	hollow shaft 径	
HB01A	140.5	98.5	68.5	24	15	0.89
HB02A	154.5	112.5	82.5	38	15	1.16
HB04A	182.5	140.5	105.5	66	15	1.69

■ **APM-HE09A(Hollow Shaft Type), APM-HE15A(Hollow Shaft Type)**

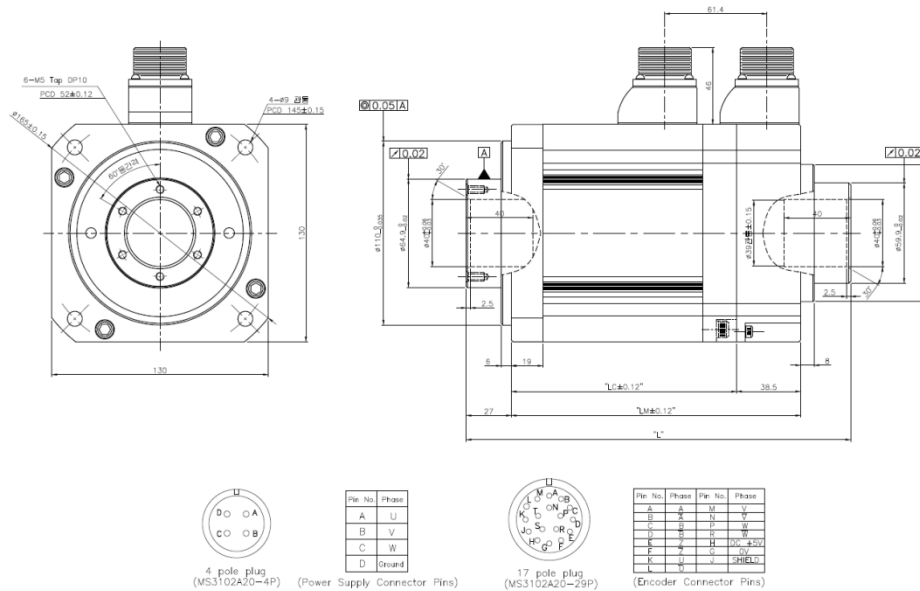

Type Name	External Dimension				Weight (Kg)
	L	LM	LC	hollow shaft	
HE09A	207	150	111.5	40	5.82
HE15A	231	174	135.5	40	7.43

■ FB Series | APM-FB01A, APM-FB02A, APM-FB04A

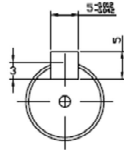

<축단 상세도 S/C 2:1>

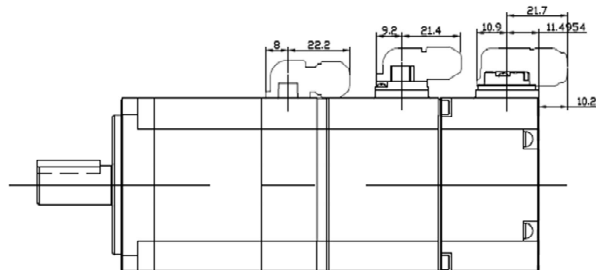
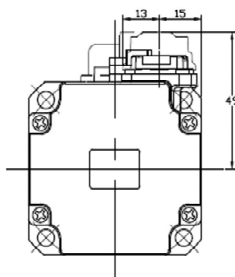
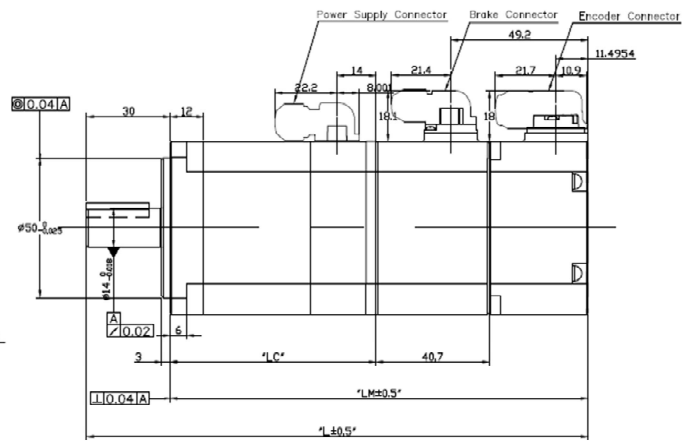
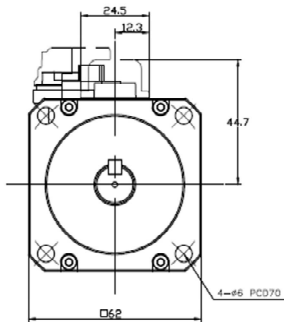
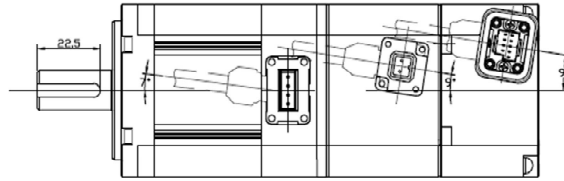

<Cable 인출 방향이, 축 반대 방향일 경우>

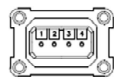

핀번호	신호명
1	W
2	V
3	U
4	접지선

<전원용 Connector 핀 배열>



Single Turn (N)		Multi Turn (M)	
핀 번호	신호명	핀 번호	신호명
1	MA	1	MA
2	SKO	2	SKO
3	-	3	OPN_B
4	DV	4	DV
5	Shield	5	Shield
6	MA	6	MA
7	SKO	7	SKO
8	-	8	VDD_B
9	+5V	9	+5V

<Encoder Connector 핀 배열>



핀번호	신호명
1	B1
2	B2

<Brake Connector 핀 배열>

Type Name	External Dimension			Weight (kg)
	L	LM	LC	
FB01A	109(149.2)	79(119.2)	43.5(43)	0.72(1.3)
FB02A	120(160.2)	90(130.2)	54.5(54)	0.94(1.49)
FB04A	140(180.2)	110(150.2)	74.5(74)	1.32(1.87)

Note 25) Please use DC 24[V] power to open the brake.

Note 26) Figures in () indicates dimensions of brake-attached type.

■ **FC Series | APM-FC04A,FC03D, APM-FC06A,FC05D,
APM-FC08A,FC06D, APM-FC10A,FC07D**

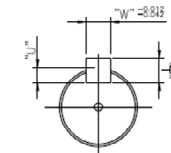

<축단 상세도, S/C 2:1>

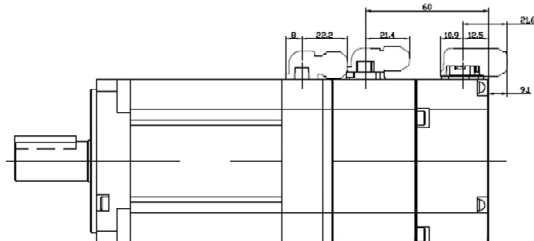
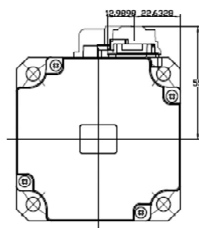
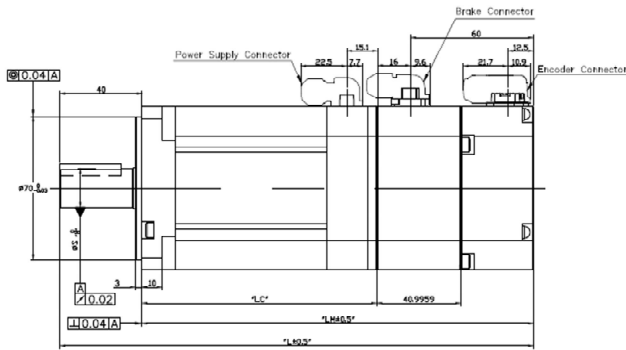
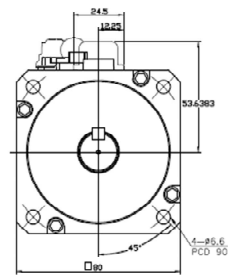
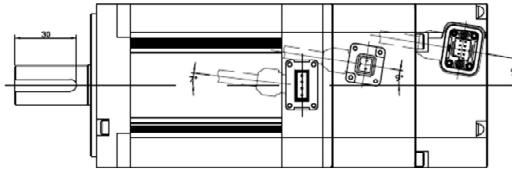

<Cable 인출 방향이, 축 반대 방향일 경우>

1	W	1	신호A	1	신호A
2	V	2	신호B	2	신호B
3	U	3	신호C	3	신호C
4	접지선	4	신호D	4	신호D
		5	신호E	5	신호E
		6	신호F	6	신호F
		7	신호G	7	신호G
		8	VCC-A	8	VCC-A
		9	VCC-B	9	VCC-B

<전원용 Connector 핀 배열> <Encoder Connector 핀 배열> <Brake Connector 핀 배열>

Type Name	External Dimension			Shaft End,Key Dimension					Weight (kg)
	L	LM	LC	S	H	T	W	U	
FC04A,FC03D	136.5(177)	96.5(137)	61(60.5)	14	-0.018	5	5	3	1.56(2.6)
FC06A,FC05D	154.5(195)	114.5(155)	79(78.5)	19	-0.021	6	6	3.5	2.18(3.22)
FC08A,FC06D	172.5(213)	132.5(173)	97(96.5)	19	-0.021	6	6	3.5	2.72(3.76)
FC10A,FC07D	190.5(231)	150.5(191)	115(114.5)	19	-0.021	6	6	3.5	3.30(4.34)

- Note 27) Please use DC 24[V] power to open the brake.
- Note 28) Figures in () indicates dimensions of brake-attached type.

■ FE Series | APM-FE09A, FE06D, FE05G, FE03M, APM-FE15A, FE11D, FE09G, FE06M, APM-FE22A, FE16D, FE13G, FE09M, APM-FE30A, FE22D, FE17G, FE12M

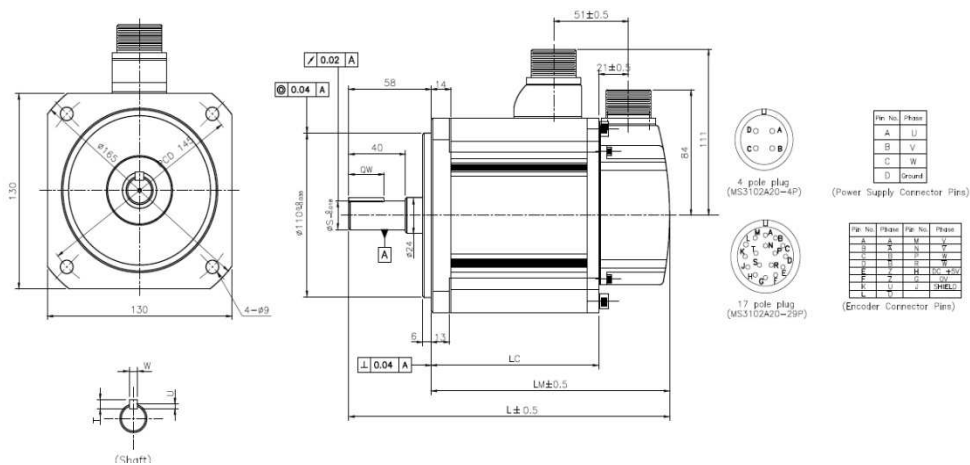

<Standard>

Type Name	External Dimension				Key Dimension				Weight (kg)
	L	LM	LC	S	QW	T	W	U	
FE09A,FE06D,FE05G,FE03M	197	139	90	19	25	5	5	3	5.04
FE15A,FE11D,FE09G,FE06M	217	159	110	19	25	5	5	3	6.74
FE22A,FE16D,FE13G,FE09M	237	179	130	22	25	6	6	3.5	8.48
FE30A,FE22D,FE17G,FE12M	255	197	148	24	36	7	8	4	10.05

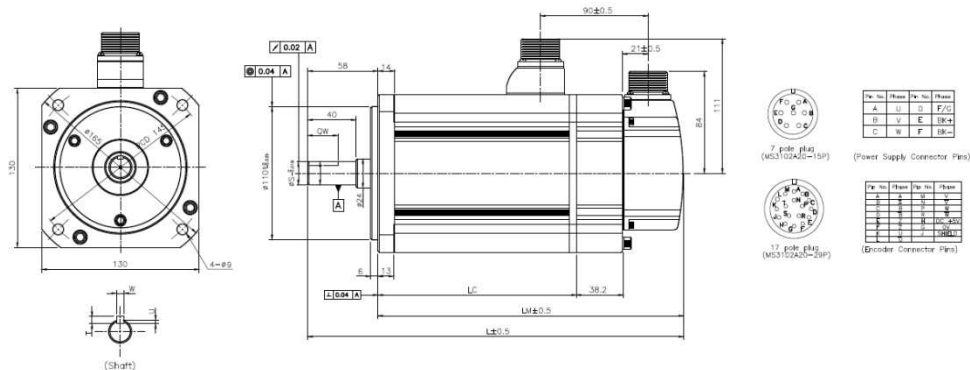

<Brake>

Type Name	External Dimension				Key Dimension				Weight (kg)
	L	LM	LC	S	QW	T	W	U	
FE09A,FE06D,FE05G,FE03M	236	178	90	19	25	5	5	3	6.58
FE15A,FE11D,FE09G,FE06M	256	198	110	19	25	5	5	3	8.28

FE22A,FE16D,FE13G,FE09M	276	218	130	22	25	6	6	3.5	10.02
FE30A,FE22D,FE17G,FE12M	294	236	148	24	36	7	8	4	11.59

Note 29) Please use DC 24[V] power to open the brake.

■ **FF Series | APM-FF30A, FF22D, FF20G, FF12M, APM-FF50A, FF35D, FF30G, FF20M, APM-FF30M, FF55D, FF44G, APM-FF44M**

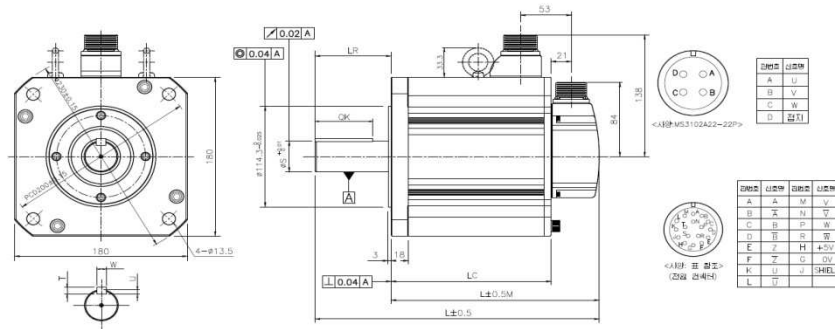

<Standard>

Type Name	External Dimension				Key Dimension					Weight (kg)
	L	LM	LC	LR	S	QK	T	W	U	
FF30A,22D,20G,12M	258	179	129	79	35	60	8	10	5	12.5
FF50A,35D,30G,20M	288	209	159							17.4
FF55D,44G,30M	332	253	203							25.2
FF44M	385	306	256		42	60	8	12	5	33.8

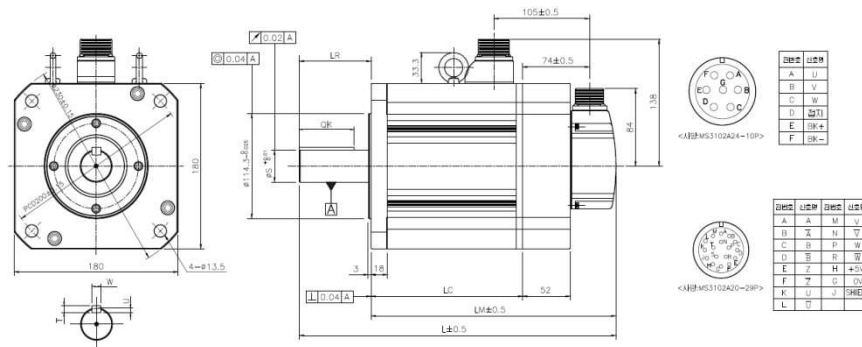

<Brake>

Type Name	External Dimension				Key Dimension					Weight (kg)
	L	LM	LC	LR	S	QK	T	W	U	
FF30A,FF22D, FF20G,FF12M	310	231	129	79	35	60	8	10	5	19.7
FF50A,35D, FF30G,FF20M										24.6
FF55D,FF44G, FF30M										32.4
FF44M										41.0

FG44M	371	306	190		42	60	50	8	12	47.26
-------	-----	-----	-----	--	----	----	----	---	----	-------

Note 32) Please use DC 90[V] power to open the brake.

16.2 ServoDrive

16.2.1 Product Features

Items		Type Name	L7PA	L7PA	L7PA	L7PA	L7PA	L7PA	L7PA
			001U	002U	004U	008U	010U	020U	035U
Input Power	Main Power	3-phase AC200 ~ 230[V](-15 ~ +10[%]), 50 ~ 60[Hz]							
	Control Power	Single-phase AC200 ~ 230[V](-15 ~ +10[%]), 50 ~ 60[Hz]							
Rated Current [A]		1.4	1.7	3.0	5.2	6.75	13.5	16.7	
Peak Current [A]		4.2	5.1	9.0	15.6	20.25	40.5	50.1	
Encoder Type		Quadrature(Incremental) BiSS-B, BiSS-C(Absolute, Incremental) Tamagawa Serial(Absolute, Incremental) EnDat 2.2							
Control Performance	Speed Control Range	Maximum 1 : 5000							
	Frequency Response	Maximum 1[kHz] or above(when 19bit Serial encoder is applied)							
	Speed Change Rate	±0.01[%] or below (with load change of 0 ~ 100[%]) ±0.1[%] or below(temperature 25±10[°C]).							
	Speedacceleration /deceleration시간	Straight or S-curveacceleration/deceleration (0~10,000[ms], 0~1,000[ms] Unitconfigurable)							
	입력 frequency	1[Mpps], line drive / 200[kpps], open collectopr							
	입력펄스방식	code+pulse string, CW+CCW, A/PHASE B							
RS422 통신Specifications	Communication Specifications	ANSI/TIA/EIA-422 StandardSpecifications							
	Communication Protocol	MODBUS-RTU							
	Connector	RJ45 x 2							
	Synchro Method	Asynchronous							
	Transmission Speed	9600 /19200/38400/57600 [bps] Can be configured at [0x3002]							
	Transmission Distance	Maximum 200 [m]							
Power Consumption	100[mA] or below								

	Terminating Resistance	Dip SW(On/Off), Built-In 120Ω
Digital Input/output	Digital Input	Input voltage range: DC 12[V] ~ DC 24[V] Total 16 input channel (allocatable) 28 function inputs can be selectively allocated (*SV_ON, *POT, *NOT, *A-RST, *START, *STOP, *REGT, *EMG, *HOME, *HSTART, *ISEL0, *ISEL1, *ISEL2, *ISEL3, *ISEL4, *ISEL5, PCON, GAIN2, P_CL, N_CL, MODE, PAUSE, ABSRQ, JSTART, JDIR, PCLR, AOVR, SPD1, SPD2, SPD3) Note) * Basic allocationsignal.
	Digital Output	Use rating: DC 24[V] ±10%, 120[mA] Total 8 input channel (allocatable) 19 function inputs can be selectively allocated (*ALARM±, *READY±, *BRAKE±, *INPOS1±, *ORG±, *EOS±, *TGON±, *TLMT±, VLMT±, INSPD±, ZSPD±, WARN±, INPOS2±, IOUT0±, IOUT1±, IOUT2±, IOUT3±, IOUT4±, IOUT5±) Note) * Standard Allocationsignal
Analog Input/output	Analog input	Total 2 channels analog speed override input(-10[V] ~ +10[V]) analog torque command input(-10[V] ~ +10[V])
	Analog output	Total 2 channels 15 function inputs can be selectively allocated
USB Communication	Functions	Firmware download, parameter setting, tuning, auxiliary function, parameter copy
	Communication Specifications	Complies with USB 2.0 Full Speed Specifications
	Connection Device	PC or USB storage media
Built-in Functions	Dynamic Braking	Standard built-in(activated by servo alarm or servo OFF)
	Regeneration braking	Built-in, external brake attachable
	Display	7 Segment(5 DIGIT)
	Self-configuration	Drive node address can be set using rotary switch
	Additional Functions	Gaintuning, alarm history, JOG operation, origin search
User Environment	Protection	Excessive current, overload, excessive current limit, overheating, excessive voltage, low voltage, excessive speed, encoder fail, position following fail, current sensing fail
	Workable Temperature / Preservation Temperature	0 ~ 50[°C] / -20 ~ 65 °C
	Workable	90[%]RH or less(no condensation)

	Temperature /Preservation Temperature	
	Others	Indoors, no corrosive/inflammablegas or liquid, no conductive dust

16.2.2 Outside View

■ L7P□A001□ ~ L7□A004□

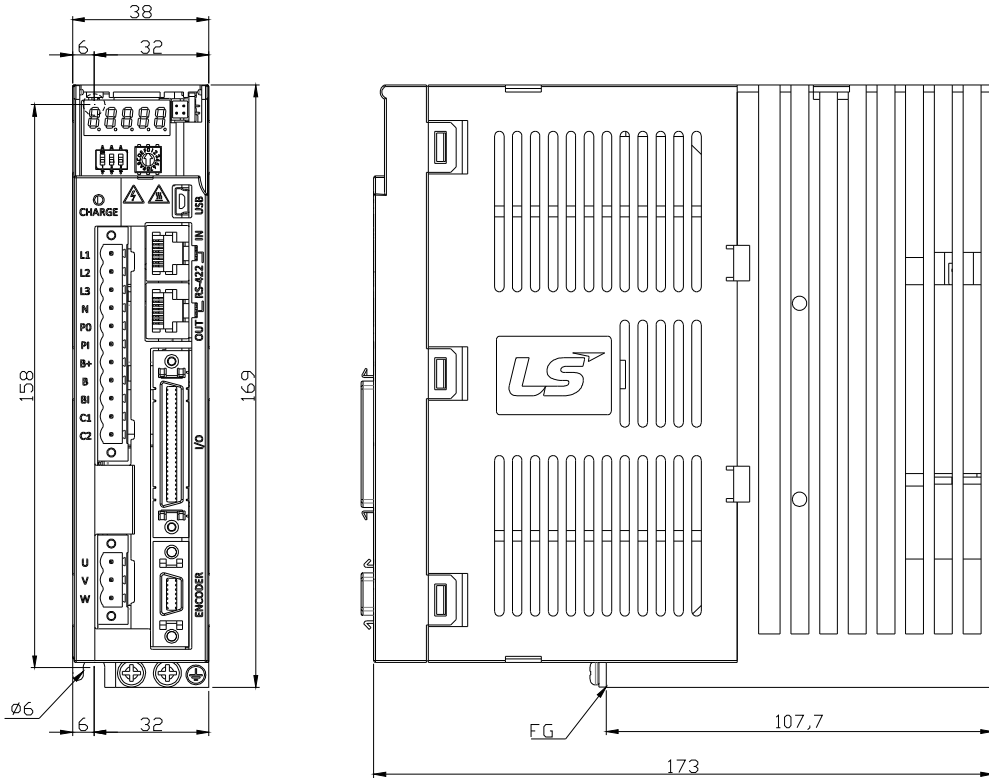

★Weight: 1.0[kg]

■ L7□A008□ / L7□A010□

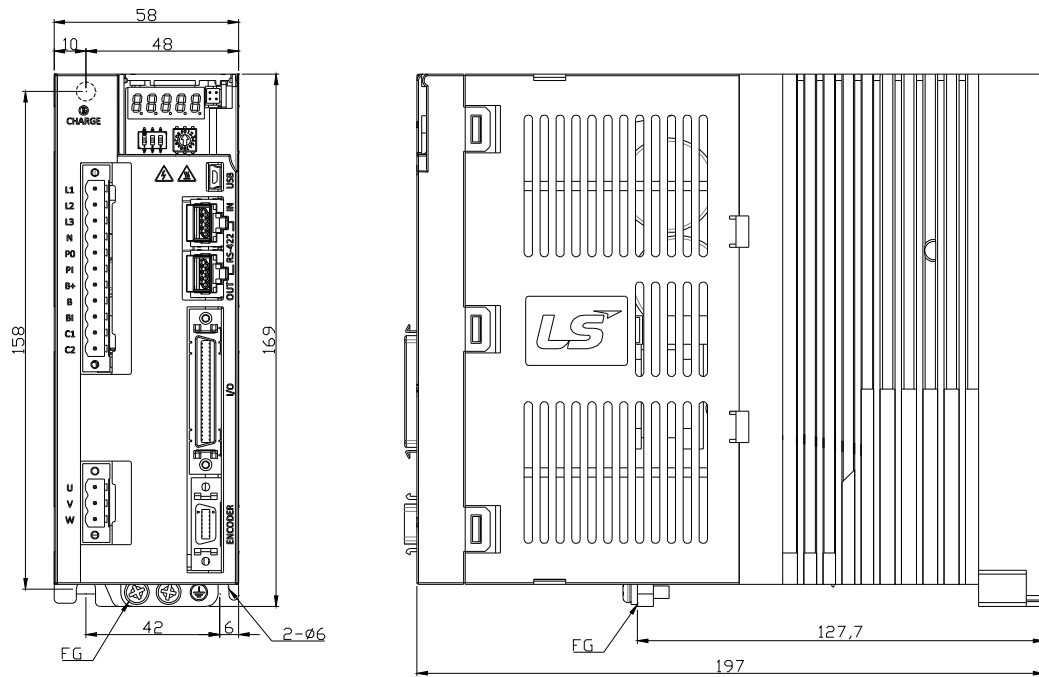

★Weight: 1.5[kg](including cooling fan)

■ L7□A020□ / L7□A035□

16.3 Options and Peripherals

Optional Specifications (SerialEncoderCable)

Classification	Product Name	Type Name(Note 1)	Applied Motor	Specifications																																																																	
For signal	SerialType 용 EncoderCable (Small Capacity AMP Type)	APCS-E CS	APM-SA (To be supported) APM-SB APM-SC SERIES (all models)	<p>motor connections drive connections(ENCODER connector)</p> <p>AMP 172161-1 CAP</p> <table border="1"> <thead> <tr> <th>PIN 번호</th> <th>Encoder 신호</th> </tr> </thead> <tbody> <tr><td>1</td><td>MA</td></tr> <tr><td>2</td><td>MA</td></tr> <tr><td>3</td><td>SLO</td></tr> <tr><td>4</td><td>SLO</td></tr> <tr><td>5</td><td>-</td></tr> <tr><td>6</td><td>-</td></tr> <tr><td>7</td><td>+5V</td></tr> <tr><td>8</td><td>0V</td></tr> <tr><td>9</td><td>SHIELD</td></tr> </tbody> </table> <p><Motor측 Connector></p> <table border="1"> <thead> <tr> <th>PIN 번호</th> <th>Encoder 신호</th> <th>PIN 번호</th> <th>Encoder 신호</th> </tr> </thead> <tbody> <tr><td>1</td><td>-</td><td>8</td><td>-</td></tr> <tr><td>2</td><td>-</td><td>9</td><td>-</td></tr> <tr><td>3</td><td>MA</td><td>10</td><td>-</td></tr> <tr><td>4</td><td>MA</td><td>11</td><td>-</td></tr> <tr><td>5</td><td>SLO</td><td>12</td><td>-</td></tr> <tr><td>6</td><td>SLO</td><td>13</td><td>-</td></tr> <tr><td>7</td><td>0V</td><td>14</td><td>+5V</td></tr> <tr><td>Plate</td><td></td><td>SHIELD</td><td></td></tr> </tbody> </table> <p><Driver측 Connector></p> <p>1.MotorConnection a. CAP Specifications(9 Position) : 172161-1(AMP) b. SOCKET Specifications : 170361-1(AMP)</p> <p>2.DriveConnection(ENCODER Connector) c. CASE Specifications : 10314-52A0-008(3M) d. CONNECTOR Specifications : 10114-3000VE(3M)</p> <p>3.CableSpecifications : 3Px0.2SQ or 3Px24AWG</p>	PIN 번호	Encoder 신호	1	MA	2	MA	3	SLO	4	SLO	5	-	6	-	7	+5V	8	0V	9	SHIELD	PIN 번호	Encoder 신호	PIN 번호	Encoder 신호	1	-	8	-	2	-	9	-	3	MA	10	-	4	MA	11	-	5	SLO	12	-	6	SLO	13	-	7	0V	14	+5V	Plate		SHIELD										
PIN 번호	Encoder 신호																																																																				
1	MA																																																																				
2	MA																																																																				
3	SLO																																																																				
4	SLO																																																																				
5	-																																																																				
6	-																																																																				
7	+5V																																																																				
8	0V																																																																				
9	SHIELD																																																																				
PIN 번호	Encoder 신호	PIN 번호	Encoder 신호																																																																		
1	-	8	-																																																																		
2	-	9	-																																																																		
3	MA	10	-																																																																		
4	MA	11	-																																																																		
5	SLO	12	-																																																																		
6	SLO	13	-																																																																		
7	0V	14	+5V																																																																		
Plate		SHIELD																																																																			
For signal	Multi-turn Type EncoderCable (Small Capacity AMP Type)	APCS-E CS1	APM-SA (to be supported) APM-SB APM-SC SERIES (all models)	<p>Motor connections drive connections (ENCODER connector)</p> <p>AMP 172161-1 CAP</p> <table border="1"> <thead> <tr> <th>PIN 번호</th> <th>Encoder 신호</th> </tr> </thead> <tbody> <tr><td>1</td><td>MA</td></tr> <tr><td>2</td><td>MA</td></tr> <tr><td>3</td><td>SL</td></tr> <tr><td>4</td><td>SL</td></tr> <tr><td>5</td><td>VDD_B</td></tr> <tr><td>6</td><td>GND_B</td></tr> <tr><td>7</td><td>+5V</td></tr> <tr><td>8</td><td>0V</td></tr> <tr><td>9</td><td>SHIELD</td></tr> </tbody> </table> <p><Motor측 Connector></p> <table border="1"> <thead> <tr> <th>PIN 번호</th> <th>Encoder 신호</th> <th>PIN 번호</th> <th>Encoder 신호</th> </tr> </thead> <tbody> <tr><td>1</td><td>-</td><td>8</td><td>-</td></tr> <tr><td>2</td><td>-</td><td>9</td><td>-</td></tr> <tr><td>3</td><td>MA</td><td>10</td><td>-</td></tr> <tr><td>4</td><td>MA</td><td>11</td><td>-</td></tr> <tr><td>5</td><td>SL</td><td>12</td><td>-</td></tr> <tr><td>6</td><td>SL</td><td>13</td><td>-</td></tr> <tr><td>7</td><td>0V</td><td>14</td><td>+5V</td></tr> <tr><td>Plate</td><td></td><td>SHILDE</td><td></td></tr> </tbody> </table> <p><Driver측 Connector></p> <table border="1"> <thead> <tr> <th>PIN 번호</th> <th>Encoder 신호</th> <th>신호</th> </tr> </thead> <tbody> <tr><td>1</td><td>BATTERY</td><td>전압</td></tr> <tr><td>2</td><td>BATTERY VV</td><td>출력</td></tr> </tbody> </table> <p><Battery Connector></p> <p>1.motorConnection a. CAP Specifications(9 Position) : 172161-1(AMP) b. SOCKET Specifications : 170361-1(AMP)</p> <p>2.DriveConnection(ENCODER Connector) a. CASE Specifications : 10314-52A0-008(3M) b. CONNECTOR Specifications : 10114-3000VE(3M)</p> <p>3.CableSpecifications : 4Px0.2SQ or 4Px24AWG</p>	PIN 번호	Encoder 신호	1	MA	2	MA	3	SL	4	SL	5	VDD_B	6	GND_B	7	+5V	8	0V	9	SHIELD	PIN 번호	Encoder 신호	PIN 번호	Encoder 신호	1	-	8	-	2	-	9	-	3	MA	10	-	4	MA	11	-	5	SL	12	-	6	SL	13	-	7	0V	14	+5V	Plate		SHILDE		PIN 번호	Encoder 신호	신호	1	BATTERY	전압	2	BATTERY VV	출력
PIN 번호	Encoder 신호																																																																				
1	MA																																																																				
2	MA																																																																				
3	SL																																																																				
4	SL																																																																				
5	VDD_B																																																																				
6	GND_B																																																																				
7	+5V																																																																				
8	0V																																																																				
9	SHIELD																																																																				
PIN 번호	Encoder 신호	PIN 번호	Encoder 신호																																																																		
1	-	8	-																																																																		
2	-	9	-																																																																		
3	MA	10	-																																																																		
4	MA	11	-																																																																		
5	SL	12	-																																																																		
6	SL	13	-																																																																		
7	0V	14	+5V																																																																		
Plate		SHILDE																																																																			
PIN 번호	Encoder 신호	신호																																																																			
1	BATTERY	전압																																																																			
2	BATTERY VV	출력																																																																			

Note 33) in the type name box represents the cable type and length: the type/length indications are as follows.

Cable Length(m)	3	5	10	20
Robot Cable	F03	F05	F10	F20
General Cable	N03	N05	N10	N20

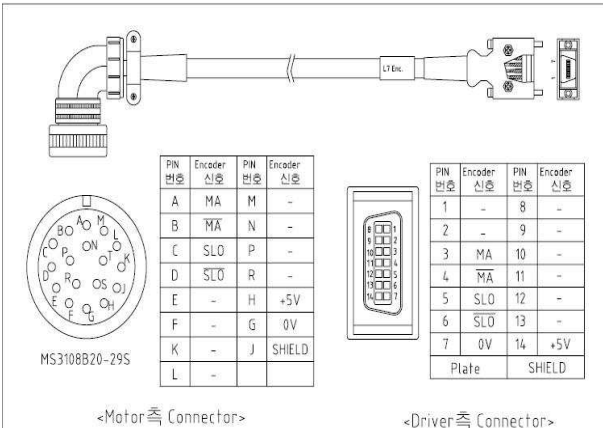
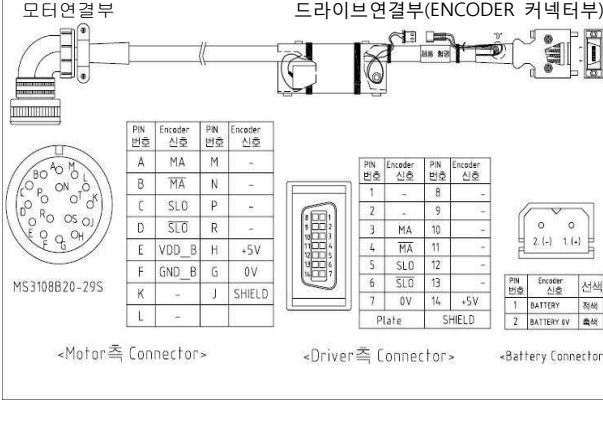
Classification	Product Name	Type Name(Note 1)	Applied Motor	Specifications																																																																																	
For signal	Serial Type EncoderCable (Medium Capacity MS Type)	APCS-E DS	APM-SE APM-SF APM-SG APM-LF APM-LG APM-FE APM-FF APM-FG SERIES (all models)	<p>모터연결부</p>  <p>MS3108B20-29S</p> <table border="1"> <thead> <tr> <th>PIN 번호</th> <th>Encoder 신호</th> <th>PIN 번호</th> <th>Encoder 신호</th> </tr> </thead> <tbody> <tr><td>A</td><td>MA</td><td>M</td><td>-</td></tr> <tr><td>B</td><td>MA</td><td>N</td><td>-</td></tr> <tr><td>C</td><td>SLO</td><td>P</td><td>-</td></tr> <tr><td>D</td><td>SLO</td><td>R</td><td>-</td></tr> <tr><td>E</td><td>-</td><td>H</td><td>+5V</td></tr> <tr><td>F</td><td>-</td><td>G</td><td>0V</td></tr> <tr><td>K</td><td>-</td><td>J</td><td>SHIELD</td></tr> <tr><td>L</td><td>-</td><td></td><td></td></tr> </tbody> </table> <p><Motor측 Connector></p> <table border="1"> <thead> <tr> <th>PIN 번호</th> <th>Encoder 신호</th> <th>PIN 번호</th> <th>Encoder 신호</th> </tr> </thead> <tbody> <tr><td>1</td><td>-</td><td>8</td><td>-</td></tr> <tr><td>2</td><td>-</td><td>9</td><td>-</td></tr> <tr><td>3</td><td>MA</td><td>10</td><td>-</td></tr> <tr><td>4</td><td>MA</td><td>11</td><td>-</td></tr> <tr><td>5</td><td>SLO</td><td>12</td><td>-</td></tr> <tr><td>6</td><td>SLO</td><td>13</td><td>-</td></tr> <tr><td>7</td><td>0V</td><td>14</td><td>+5V</td></tr> <tr><td>Plate</td><td></td><td></td><td>SHIELD</td></tr> </tbody> </table> <p><Driver측 Connector></p> <p>1.motorConnection(MS:Military Standard) a. PLUG Specifications : MS3108B(MS3106B) 20-29S 2.DriveConnection(ENCODER Connector) a. CASE Specifications : 10314-52A0-008(3M) b. CONNECTOR Specifications : 10114-3000VE(3M) 3.CableSpecifications : 4Px0.2SQ or 4Px24AWG</p>	PIN 번호	Encoder 신호	PIN 번호	Encoder 신호	A	MA	M	-	B	MA	N	-	C	SLO	P	-	D	SLO	R	-	E	-	H	+5V	F	-	G	0V	K	-	J	SHIELD	L	-			PIN 번호	Encoder 신호	PIN 번호	Encoder 신호	1	-	8	-	2	-	9	-	3	MA	10	-	4	MA	11	-	5	SLO	12	-	6	SLO	13	-	7	0V	14	+5V	Plate			SHIELD									
PIN 번호	Encoder 신호	PIN 번호	Encoder 신호																																																																																		
A	MA	M	-																																																																																		
B	MA	N	-																																																																																		
C	SLO	P	-																																																																																		
D	SLO	R	-																																																																																		
E	-	H	+5V																																																																																		
F	-	G	0V																																																																																		
K	-	J	SHIELD																																																																																		
L	-																																																																																				
PIN 번호	Encoder 신호	PIN 번호	Encoder 신호																																																																																		
1	-	8	-																																																																																		
2	-	9	-																																																																																		
3	MA	10	-																																																																																		
4	MA	11	-																																																																																		
5	SLO	12	-																																																																																		
6	SLO	13	-																																																																																		
7	0V	14	+5V																																																																																		
Plate			SHIELD																																																																																		
For signal	Multi-turn Type EncoderCable (Medium Capacity MS Type)	APCS-E DS1	APM-SE APM-SF APM-SG APM-LF APM-LG APM-FE APM-FF APM-FG SERIES (all models)	<p>모터연결부</p>  <p>MS3108B20-29S</p> <table border="1"> <thead> <tr> <th>PIN 번호</th> <th>Encoder 신호</th> <th>PIN 번호</th> <th>Encoder 신호</th> </tr> </thead> <tbody> <tr><td>A</td><td>MA</td><td>M</td><td>-</td></tr> <tr><td>B</td><td>MA</td><td>N</td><td>-</td></tr> <tr><td>C</td><td>SLO</td><td>P</td><td>-</td></tr> <tr><td>D</td><td>SLO</td><td>R</td><td>-</td></tr> <tr><td>E</td><td>VDD_B</td><td>H</td><td>+5V</td></tr> <tr><td>F</td><td>GND_B</td><td>G</td><td>0V</td></tr> <tr><td>K</td><td>-</td><td>J</td><td>SHIELD</td></tr> <tr><td>L</td><td>-</td><td></td><td></td></tr> </tbody> </table> <p><Motor측 Connector></p> <table border="1"> <thead> <tr> <th>PIN 번호</th> <th>Encoder 신호</th> <th>PIN 번호</th> <th>Encoder 신호</th> </tr> </thead> <tbody> <tr><td>1</td><td>-</td><td>8</td><td>-</td></tr> <tr><td>2</td><td>-</td><td>9</td><td>-</td></tr> <tr><td>3</td><td>MA</td><td>10</td><td>-</td></tr> <tr><td>4</td><td>MA</td><td>11</td><td>-</td></tr> <tr><td>5</td><td>SLO</td><td>12</td><td>-</td></tr> <tr><td>6</td><td>SLO</td><td>13</td><td>-</td></tr> <tr><td>7</td><td>0V</td><td>14</td><td>+5V</td></tr> <tr><td>Plate</td><td></td><td></td><td>SHIELD</td></tr> </tbody> </table> <p><Driver측 Connector></p> <table border="1"> <thead> <tr> <th>PIN 번호</th> <th>Encoder 신호</th> <th>신호</th> </tr> </thead> <tbody> <tr><td>1</td><td>BATTERY</td><td>전원</td></tr> <tr><td>2</td><td>BATTERY</td><td>0V</td></tr> </tbody> </table> <p><Battery Connector></p> <p>1.motorConnection a. CAP Specifications(9 Position) : MS 3108B 20-29S 2.DriveConnection(ENCODER Connector) a. CASE Specifications : 10314-52A0-008(3M) b. CONNECTOR Specifications : 10114-3000VE(3M) 3.CableSpecifications : 4Px0.2SQ or 4Px24AWG</p> <p>드라이브연결부(ENCODER 커넥터부)</p>	PIN 번호	Encoder 신호	PIN 번호	Encoder 신호	A	MA	M	-	B	MA	N	-	C	SLO	P	-	D	SLO	R	-	E	VDD_B	H	+5V	F	GND_B	G	0V	K	-	J	SHIELD	L	-			PIN 번호	Encoder 신호	PIN 번호	Encoder 신호	1	-	8	-	2	-	9	-	3	MA	10	-	4	MA	11	-	5	SLO	12	-	6	SLO	13	-	7	0V	14	+5V	Plate			SHIELD	PIN 번호	Encoder 신호	신호	1	BATTERY	전원	2	BATTERY	0V
PIN 번호	Encoder 신호	PIN 번호	Encoder 신호																																																																																		
A	MA	M	-																																																																																		
B	MA	N	-																																																																																		
C	SLO	P	-																																																																																		
D	SLO	R	-																																																																																		
E	VDD_B	H	+5V																																																																																		
F	GND_B	G	0V																																																																																		
K	-	J	SHIELD																																																																																		
L	-																																																																																				
PIN 번호	Encoder 신호	PIN 번호	Encoder 신호																																																																																		
1	-	8	-																																																																																		
2	-	9	-																																																																																		
3	MA	10	-																																																																																		
4	MA	11	-																																																																																		
5	SLO	12	-																																																																																		
6	SLO	13	-																																																																																		
7	0V	14	+5V																																																																																		
Plate			SHIELD																																																																																		
PIN 번호	Encoder 신호	신호																																																																																			
1	BATTERY	전원																																																																																			
2	BATTERY	0V																																																																																			

Note 34) in the type name box represents the cable type and length: the type/length indications are as follows..

Cable Length(m)	3	5	10	20
Robot Cable	F03	F05	F10	F20
General Cable	N03	N05	N10	N20

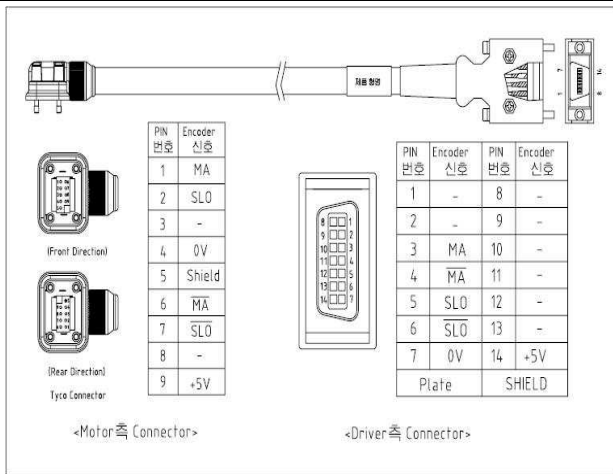
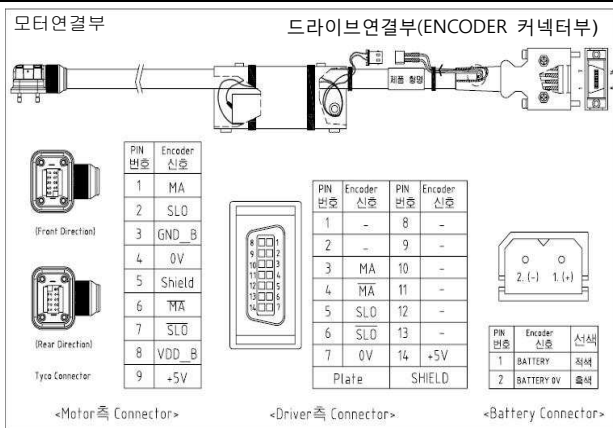
Classification	Product Name	Type Name(Note 1)	Applied Motor	Specifications																																																																	
For signal	EncoderCable for flat motor(Small Capacity)	APCS-E ES- *Front : APCS-E ES (load side) * Rear : APCS-E ES-R (half load side)	APM-FB APM-FC SERIES (all models)	 <p> <table border="1"> <thead> <tr> <th>PIN 번호</th> <th>Encoder 신호</th> </tr> </thead> <tbody> <tr><td>1</td><td>MA</td></tr> <tr><td>2</td><td>SLO</td></tr> <tr><td>3</td><td>-</td></tr> <tr><td>4</td><td>0V</td></tr> <tr><td>5</td><td>Shield</td></tr> <tr><td>6</td><td>MA</td></tr> <tr><td>7</td><td>SLO</td></tr> <tr><td>8</td><td>-</td></tr> <tr><td>9</td><td>+5V</td></tr> </tbody> </table> <table border="1"> <thead> <tr> <th>PIN 번호</th> <th>Encoder 신호</th> <th>PIN 번호</th> <th>Encoder 신호</th> </tr> </thead> <tbody> <tr><td>1</td><td>-</td><td>8</td><td>-</td></tr> <tr><td>2</td><td>-</td><td>9</td><td>-</td></tr> <tr><td>3</td><td>MA</td><td>10</td><td>-</td></tr> <tr><td>4</td><td>MA</td><td>11</td><td>-</td></tr> <tr><td>5</td><td>SLO</td><td>12</td><td>-</td></tr> <tr><td>6</td><td>SLO</td><td>13</td><td>-</td></tr> <tr><td>7</td><td>0V</td><td>14</td><td>+5V</td></tr> <tr><td>Plate</td><td></td><td>SHIELD</td><td></td></tr> </tbody> </table> </p> <p> 1.motorConnection a. CAP Specifications : 2201825-1(Tyco 사) b. SOCKET Specifications : 2174065-4(Tyco 사) 2.DriveConnection(ENCODER Connector) a. CASE Specifications : 10314-52A0-008(3M) b. CONNECTOR Specifications : 10114-3000VE(3M) 3.CableSpecifications : 4Px0.2SQ or 4Px24AWG </p>	PIN 번호	Encoder 신호	1	MA	2	SLO	3	-	4	0V	5	Shield	6	MA	7	SLO	8	-	9	+5V	PIN 번호	Encoder 신호	PIN 번호	Encoder 신호	1	-	8	-	2	-	9	-	3	MA	10	-	4	MA	11	-	5	SLO	12	-	6	SLO	13	-	7	0V	14	+5V	Plate		SHIELD										
PIN 번호	Encoder 신호																																																																				
1	MA																																																																				
2	SLO																																																																				
3	-																																																																				
4	0V																																																																				
5	Shield																																																																				
6	MA																																																																				
7	SLO																																																																				
8	-																																																																				
9	+5V																																																																				
PIN 번호	Encoder 신호	PIN 번호	Encoder 신호																																																																		
1	-	8	-																																																																		
2	-	9	-																																																																		
3	MA	10	-																																																																		
4	MA	11	-																																																																		
5	SLO	12	-																																																																		
6	SLO	13	-																																																																		
7	0V	14	+5V																																																																		
Plate		SHIELD																																																																			
For signal	Multi-turn EncoderCable for flat motor (Small Capacity)	APCS-E ES1- *Front : APCS-E ES1 (load side) * Rear : APCS-E ES1-R (half load side)	APM-FB APM-FC SERIES (all models)	 <p> <table border="1"> <thead> <tr> <th>PIN 번호</th> <th>Encoder 신호</th> </tr> </thead> <tbody> <tr><td>1</td><td>MA</td></tr> <tr><td>2</td><td>SLO</td></tr> <tr><td>3</td><td>GND_B</td></tr> <tr><td>4</td><td>0V</td></tr> <tr><td>5</td><td>Shield</td></tr> <tr><td>6</td><td>MA</td></tr> <tr><td>7</td><td>SLO</td></tr> <tr><td>8</td><td>VDD_B</td></tr> <tr><td>9</td><td>+5V</td></tr> </tbody> </table> <table border="1"> <thead> <tr> <th>PIN 번호</th> <th>Encoder 신호</th> <th>PIN 번호</th> <th>Encoder 신호</th> </tr> </thead> <tbody> <tr><td>1</td><td>-</td><td>8</td><td>-</td></tr> <tr><td>2</td><td>-</td><td>9</td><td>-</td></tr> <tr><td>3</td><td>MA</td><td>10</td><td>-</td></tr> <tr><td>4</td><td>MA</td><td>11</td><td>-</td></tr> <tr><td>5</td><td>SLO</td><td>12</td><td>-</td></tr> <tr><td>6</td><td>SLO</td><td>13</td><td>-</td></tr> <tr><td>7</td><td>0V</td><td>14</td><td>+5V</td></tr> <tr><td>Plate</td><td></td><td>SHIELD</td><td></td></tr> </tbody> </table> <table border="1"> <thead> <tr> <th>PIN 번호</th> <th>Encoder 신호</th> <th>신호</th> </tr> </thead> <tbody> <tr><td>1</td><td>BATTERY</td><td>전원</td></tr> <tr><td>2</td><td>BATTERY 0V</td><td>공전</td></tr> </tbody> </table> </p> <p> 1.motorConnection a. CAP Specifications(9 Position) : 2201825-1(Tyco 사) b. SOCKET Specifications : 2174065-4(Tyco 사) 2.DriveConnection(ENCODER Connector) a. CASE Specifications : 10314-52A0-008(3M) b. CONNECTOR Specifications : 10114-3000VE(3M) 3.CableSpecifications : 4Px0.2SQ or 4Px24AWG </p>	PIN 번호	Encoder 신호	1	MA	2	SLO	3	GND_B	4	0V	5	Shield	6	MA	7	SLO	8	VDD_B	9	+5V	PIN 번호	Encoder 신호	PIN 번호	Encoder 신호	1	-	8	-	2	-	9	-	3	MA	10	-	4	MA	11	-	5	SLO	12	-	6	SLO	13	-	7	0V	14	+5V	Plate		SHIELD		PIN 번호	Encoder 신호	신호	1	BATTERY	전원	2	BATTERY 0V	공전
PIN 번호	Encoder 신호																																																																				
1	MA																																																																				
2	SLO																																																																				
3	GND_B																																																																				
4	0V																																																																				
5	Shield																																																																				
6	MA																																																																				
7	SLO																																																																				
8	VDD_B																																																																				
9	+5V																																																																				
PIN 번호	Encoder 신호	PIN 번호	Encoder 신호																																																																		
1	-	8	-																																																																		
2	-	9	-																																																																		
3	MA	10	-																																																																		
4	MA	11	-																																																																		
5	SLO	12	-																																																																		
6	SLO	13	-																																																																		
7	0V	14	+5V																																																																		
Plate		SHIELD																																																																			
PIN 번호	Encoder 신호	신호																																																																			
1	BATTERY	전원																																																																			
2	BATTERY 0V	공전																																																																			

Note 35) in the type name box represents the cable type and length: the type/length indications are as follows..

Cable Length(m)	3	5	10	20
Robot Cable	F03	F05	F10	F20
General Cable	N03	N05	N10	N20

Classification	Product Name	Type Name(Not e 1)	Applied Motor	Specifications																	
For power	PowerCable (Medium Capacity)	APCS- P IS	APM-SF30A APM-SF22D APM-LF35D APM-SF20G APM-LF30G APM-SF12M APM-SF20M APM-LF30M APM-SG20G APM-SG30G APM-SG22D APM-SG35D APM-SG12M APM-SG20M APM-SG30M	<p>모터연결부</p> <p>드라이브연결부</p> <p>MS3108B22-22S</p> <table border="1"> <thead> <tr> <th>항목</th> <th>Lead Wire 상표시</th> <th>PIN 번호</th> </tr> </thead> <tbody> <tr> <td rowspan="4">Motor 결선</td> <td>U</td> <td>A</td> </tr> <tr> <td>V</td> <td>B</td> </tr> <tr> <td>W</td> <td>C</td> </tr> <tr> <td>Ground</td> <td>D</td> </tr> </tbody> </table> <p><DRIVE측 연결부></p> <p><MOTOR측 연결부></p> <ol style="list-style-type: none"> 1.motorConnection(MS : Military Standard) <ol style="list-style-type: none"> a. PLUG Specifications : MS3108B(MS3106B)22-22S 2.DriveConnection(U,V,W,FG) <ol style="list-style-type: none"> a. U,V,W PinSpecifications: F2512 b. FG PinSpecifications: 2.5x4 (Ring Terminal) 3.CableSpecifications: 4Cx2.5SQ or 4Cx14AWG 	항목	Lead Wire 상표시	PIN 번호	Motor 결선	U	A	V	B	W	C	Ground	D					
항목	Lead Wire 상표시	PIN 번호																			
Motor 결선	U	A																			
	V	B																			
	W	C																			
	Ground	D																			
For power	Standard 형 BrakeCable	APCS- P PB	APM-SF30A APM-SF22D APM-LF35D APM-SF20G APM-LF30G APM-SF12M APM-SF20M APM-LF30M APM-SG20G APM-SG30G APM-SG22D APM-SG35D APM-SG12M APM-SG20M APM-SG30M	<p>모터연결부</p> <p>드라이브연결부</p> <p>MS3108B24-10S</p> <table border="1"> <thead> <tr> <th>항목</th> <th>Lead wire 상표시</th> <th>PIN 번호</th> </tr> </thead> <tbody> <tr> <td rowspan="4">Motor 결선</td> <td>U</td> <td>A</td> </tr> <tr> <td>V</td> <td>B</td> </tr> <tr> <td>W</td> <td>C</td> </tr> <tr> <td>Ground</td> <td>D</td> </tr> <tr> <td rowspan="2">Brake 결선</td> <td>+</td> <td>E</td> </tr> <tr> <td>-</td> <td>F</td> </tr> </tbody> </table> <p><Motor측 연결부></p> <ol style="list-style-type: none"> 1.motorConnection(MS : Military Standard) <ol style="list-style-type: none"> a. PLUG Specifications : MS3108B(MS3106B)24-10S 2.DriveConnection(U,V,W,FG) <ol style="list-style-type: none"> a. U,V,W PinSpecifications: F2512 b. FG PinSpecifications: 2.5x4 (Ring Terminal) 3.CableSpecifications: 4Cx2.5SQ or 4Cx14AWG 4.BrakeFor power <ol style="list-style-type: none"> a.Connection TerminalSpecifications : 1.5x3(Ring Terminal) b.CableSpecifications : 4Cx0.75SQ or 4Cx18AWG 	항목	Lead wire 상표시	PIN 번호	Motor 결선	U	A	V	B	W	C	Ground	D	Brake 결선	+	E	-	F
항목	Lead wire 상표시	PIN 번호																			
Motor 결선	U	A																			
	V	B																			
	W	C																			
	Ground	D																			
Brake 결선	+	E																			
	-	F																			

Note 2) in the type name box represents the cable type and length: the type/length indications are as follows..

Cable Length(m)	3	5	10	20
Robot Cable	F03	F05	F10	F20
General Cable	N03	N05	N10	N20

Classification	Product Name	Type Name(Not e 1)	Applied Motor	Specifications
For power	StandardType For powerCable	APC-P GS	APM-SF50A APM-SF55D APM-SF44G APM-SF44M APM-SG55D APM-SG44G APM-SG44M	<p>MS3108B22-22S</p> <p><Motor측 연결부></p> <p>1.motorConnection(MS : Military Standard) a. PLUG Specifications : MS3108B(MS3106B)22-22S 2.DriveConnection(U,V,W,FG) a. U,V,W,FG PinSpecifications: 6.0x5(Ring Terminal) 3.CableSpecifications: 4Cx6.0SQ or 4Cx10AWG</p>
For power	StandardType BrakeCable	APC-P PB	APM-SF50A APM-SF55D APM-SF44G APM-SF44M APM-SG55D APM-SG44G APM-SG44M	<p>MS3108B24-10S</p> <p><Motor측 연결부></p> <p>1.motorConnection(MS : Military Standard) a. PLUG Specifications : MS3108B(MS3106B)24-10S 2.DriveConnection(U,V,W,FG) a. U,V,W,FG PinSpecifications: 6.0x5(Ring Terminal) 3.CableSpecifications: 4Cx6.0SQ or 4Cx10AWG 4.BrakeFor power a.Connection TerminalSpecifications : 1.5x3(Ring Terminal) b.CableSpecifications : 4Cx0.75SQ or 4Cx18AWG</p>

Note 3) in the type name box represents the cable type and length: the type/length indications are as follows..

Cable Length(m)	3	5	10	20
Robot Cable	F03	F05	F10	F20
General Cable	N03	N05	N10	N20

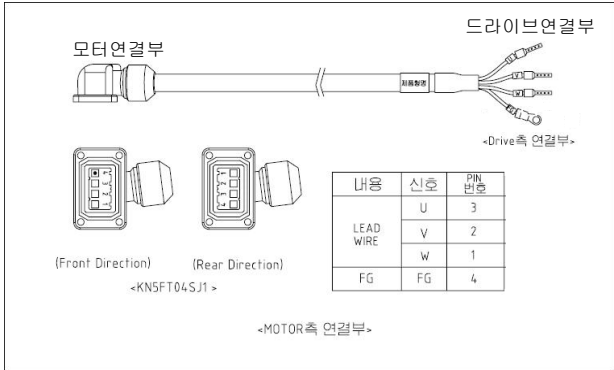
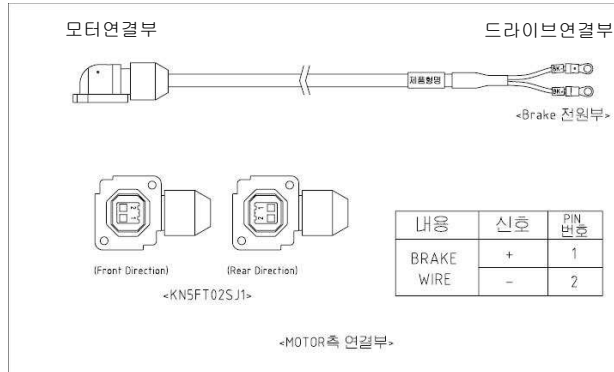
Classification	Product Name	Type Name(Note 1)	Applied Motor	Specifications
For power	Flat Motor PowerCable (Small Capacity)	APCS-P FS *Front : APCS-P FS (load side) * Rear : APCS-P FS-R (half load side)	APM-FB APM-FC SERES (all models)	 <p>1.motorConnection a. PLUG Specifications : KN5FT04SJ1(JAE 사) b. PLUG Specifications : ST-KN-S-C1B-3500 (JAE 사) 2.DriveConnection(U,V,W,FG) a. U,V,W PinSpecifications: F1512 b. FG PinSpecifications: 1.5x4 (Ring Terminal) 3.CableSpecifications: 4Cx0.75SQ or 4Cx18AWG</p>
For power	Flat Motor BrakeCable (Small Capacity)	APCS-B QS *Front : APCS-B QS (load side) * Rear : APCS-B QS-R (half load side)	APM-FB APM-FC SERES (all models)	 <p>1.motorConnection a. PLUG Specifications : KN5FT02SJ1(JAE) b. SOCKETSpecifications : ST-KN-S-C1B-3500 (JAE) 2.BrakeFor power a.Connection TerminalSpecifications : 1.5x3(Ring Terminal) 3.CableSpecifications: 2Cx0.75SQ or 2Cx18AWG</p>

Note 4) in the type name box represents the cable type and length: the type/length indications are as follows..

Cable Length(m)	3	5	10	20
Robot Cable	F03	F05	F10	F20
General Cable	N03	N05	N10	N20

Classification	Product Name	Type Name(Note 1)	Applied Motor	Specifications									
For power		APC-P SB	APM-SG APM-LG APM-FG Series (all models)	<table border="1" style="margin-left: auto; margin-right: auto;"> <thead> <tr> <th>항목</th> <th>신호</th> <th>PIN 번호</th> </tr> </thead> <tbody> <tr> <td>Brake</td> <td>+</td> <td>A</td> </tr> <tr> <td>결선</td> <td>-</td> <td>B</td> </tr> </tbody> </table> <p>1.motorConnection a. PLUG Specifications : MS3108B14-7S(MS 사) 2.BrakeFor power a.Connection TerminalSpecifications : 1.5x3(Ring Terminal) 3.CableSpecifications: 2Cx0.75SQ or 2Cx19AWG</p>	항목	신호	PIN 번호	Brake	+	A	결선	-	B
항목	신호	PIN 번호											
Brake	+	A											
결선	-	B											

Note 5) in the type name box represents the cable type and length: the type/length indications are as follows..

Cable Length(m)	3	5	10	20
Robot Cable	F03	F05	F10	F20
General Cable	N03	N05	N10	N20

■Optional Specifications (Cable)

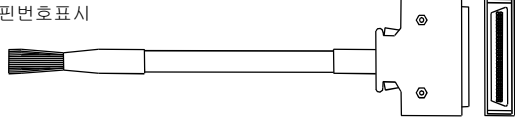
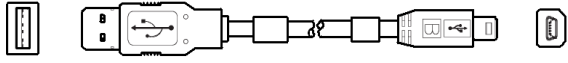
Class ificati on	Product Name	Type Name(Note 1)	Applied Drive	Specifications																																																																																																																																																																																																																												
For signal	I/O Cable	APC-CN1 A	L7 SERIES	<p>controller Drive connections</p> <p>핀번호표시</p>  <p>10. DriveConnection(I/O) e. CASE Specifications : 10350-52A0-008(3M) c. CONNECTOR Specifications : 10150-3000VE(3M) d. CABLE Specifications : ROW-SB0.1Cx50C(AWG 28)</p> <table border="1"> <thead> <tr> <th>CN1</th> <th>선색상</th> <th>CN1</th> <th>선색상</th> <th>CN1</th> <th>선색상</th> <th>CN1</th> <th>선색상</th> <th>CN1</th> <th>선색상</th> </tr> </thead> <tbody> <tr><td>1</td><td>주황/검정1점</td><td>11</td><td>주황/검정2점</td><td>21</td><td>주황/검정3점</td><td>31</td><td>주황/검정4점</td><td>41</td><td>주황/검정5점</td></tr> <tr><td>2</td><td>주황/빨강1점</td><td>12</td><td>주황/빨강2점</td><td>22</td><td>주황/빨강3점</td><td>32</td><td>주황/빨강4점</td><td>42</td><td>주황/빨강5점</td></tr> <tr><td>3</td><td>노랑/검정1점</td><td>13</td><td>노랑/검정2점</td><td>23</td><td>노랑/검정3점</td><td>33</td><td>노랑/검정4점</td><td>43</td><td>노랑/검정5점</td></tr> <tr><td>4</td><td>노랑/빨강1점</td><td>14</td><td>노랑/빨강2점</td><td>24</td><td>노랑/빨강3점</td><td>34</td><td>노랑/빨강4점</td><td>44</td><td>노랑/빨강5점</td></tr> <tr><td>5</td><td>흰색/검정1점</td><td>15</td><td>흰색/검정2점</td><td>25</td><td>흰색/검정3점</td><td>35</td><td>흰색/검정4점</td><td>45</td><td>흰색/검정5점</td></tr> <tr><td>6</td><td>흰색/빨강1점</td><td>16</td><td>흰색/빨강2점</td><td>26</td><td>흰색/빨강3점</td><td>36</td><td>흰색/빨강4점</td><td>46</td><td>흰색/빨강5점</td></tr> <tr><td>7</td><td>흰색/검정1점</td><td>17</td><td>흰색/검정2점</td><td>27</td><td>흰색/검정3점</td><td>37</td><td>흰색/검정4점</td><td>47</td><td>흰색/검정5점</td></tr> <tr><td>8</td><td>흰색/빨강1점</td><td>18</td><td>흰색/빨강2점</td><td>28</td><td>흰색/빨강3점</td><td>38</td><td>흰색/빨강4점</td><td>48</td><td>흰색/빨강5점</td></tr> <tr><td>9</td><td>분홍/검정1점</td><td>19</td><td>분홍/검정2점</td><td>29</td><td>분홍/검정3점</td><td>39</td><td>분홍/검정4점</td><td>49</td><td>분홍/검정5점</td></tr> <tr><td>10</td><td>분홍/빨강1점</td><td>20</td><td>분홍/빨강2점</td><td>30</td><td>분홍/빨강3점</td><td>40</td><td>분홍/빨강4점</td><td>50</td><td>분홍/빨강5점</td></tr> </tbody> </table> <table border="1"> <thead> <tr> <th>NO</th> <th>PIN기능</th> <th>NO</th> <th>PIN기능</th> <th>NO</th> <th>PIN기능</th> <th>NO</th> <th>PIN기능</th> <th>NO</th> <th>PIN기능</th> </tr> </thead> <tbody> <tr><td>1</td><td>TRQCOM</td><td>11</td><td>PR+</td><td>21</td><td>SPD3/MODE</td><td>31</td><td>/BO</td><td>41</td><td>RDY-</td></tr> <tr><td>2</td><td>REFCOM</td><td>12</td><td>PR-</td><td>22</td><td>SPD2</td><td>32</td><td>AO</td><td>42</td><td>TLOUT</td></tr> <tr><td>3</td><td>PZO</td><td>13</td><td>PCON</td><td>23</td><td>SPD1</td><td>33</td><td>/AO</td><td>43</td><td>ZSPD</td></tr> <tr><td>4</td><td>ZO</td><td>14</td><td>GAIN2(SEN)</td><td>24</td><td>GND</td><td>34</td><td>+15V</td><td>44</td><td>BRAKE</td></tr> <tr><td>5</td><td>/ZO</td><td>15</td><td>PCLEAR</td><td>25</td><td>GND</td><td>35</td><td>-15V</td><td>45</td><td>INSPD/INPOS</td></tr> <tr><td>6</td><td>SRO</td><td>16</td><td>TLIMIT</td><td>26</td><td>SETCOM</td><td>36</td><td>GND</td><td>46</td><td>DIR</td></tr> <tr><td>7</td><td>/SRO</td><td>17</td><td>ALMRST</td><td>27</td><td>SPDCOM</td><td>37</td><td>GND</td><td>47</td><td>SVON</td></tr> <tr><td>8</td><td>GND</td><td>18</td><td>EMG</td><td>28</td><td>MONIT1</td><td>38</td><td>ALARM+</td><td>48</td><td>STOP</td></tr> <tr><td>9</td><td>PF+</td><td>19</td><td>CWLIM</td><td>29</td><td>MONIT2</td><td>39</td><td>ALARM-</td><td>49</td><td>PULCOM</td></tr> <tr><td>10</td><td>PF-</td><td>20</td><td>CCWLIM</td><td>30</td><td>BO</td><td>40</td><td>RDY+</td><td>50</td><td>+24Vin</td></tr> </tbody> </table> <p>- Same as APC-VSCN1T</p>	CN1	선색상	CN1	선색상	CN1	선색상	CN1	선색상	CN1	선색상	1	주황/검정1점	11	주황/검정2점	21	주황/검정3점	31	주황/검정4점	41	주황/검정5점	2	주황/빨강1점	12	주황/빨강2점	22	주황/빨강3점	32	주황/빨강4점	42	주황/빨강5점	3	노랑/검정1점	13	노랑/검정2점	23	노랑/검정3점	33	노랑/검정4점	43	노랑/검정5점	4	노랑/빨강1점	14	노랑/빨강2점	24	노랑/빨강3점	34	노랑/빨강4점	44	노랑/빨강5점	5	흰색/검정1점	15	흰색/검정2점	25	흰색/검정3점	35	흰색/검정4점	45	흰색/검정5점	6	흰색/빨강1점	16	흰색/빨강2점	26	흰색/빨강3점	36	흰색/빨강4점	46	흰색/빨강5점	7	흰색/검정1점	17	흰색/검정2점	27	흰색/검정3점	37	흰색/검정4점	47	흰색/검정5점	8	흰색/빨강1점	18	흰색/빨강2점	28	흰색/빨강3점	38	흰색/빨강4점	48	흰색/빨강5점	9	분홍/검정1점	19	분홍/검정2점	29	분홍/검정3점	39	분홍/검정4점	49	분홍/검정5점	10	분홍/빨강1점	20	분홍/빨강2점	30	분홍/빨강3점	40	분홍/빨강4점	50	분홍/빨강5점	NO	PIN기능	NO	PIN기능	NO	PIN기능	NO	PIN기능	NO	PIN기능	1	TRQCOM	11	PR+	21	SPD3/MODE	31	/BO	41	RDY-	2	REFCOM	12	PR-	22	SPD2	32	AO	42	TLOUT	3	PZO	13	PCON	23	SPD1	33	/AO	43	ZSPD	4	ZO	14	GAIN2(SEN)	24	GND	34	+15V	44	BRAKE	5	/ZO	15	PCLEAR	25	GND	35	-15V	45	INSPD/INPOS	6	SRO	16	TLIMIT	26	SETCOM	36	GND	46	DIR	7	/SRO	17	ALMRST	27	SPDCOM	37	GND	47	SVON	8	GND	18	EMG	28	MONIT1	38	ALARM+	48	STOP	9	PF+	19	CWLIM	29	MONIT2	39	ALARM-	49	PULCOM	10	PF-	20	CCWLIM	30	BO	40	RDY+	50	+24Vin
CN1	선색상	CN1	선색상	CN1	선색상	CN1	선색상	CN1	선색상																																																																																																																																																																																																																							
1	주황/검정1점	11	주황/검정2점	21	주황/검정3점	31	주황/검정4점	41	주황/검정5점																																																																																																																																																																																																																							
2	주황/빨강1점	12	주황/빨강2점	22	주황/빨강3점	32	주황/빨강4점	42	주황/빨강5점																																																																																																																																																																																																																							
3	노랑/검정1점	13	노랑/검정2점	23	노랑/검정3점	33	노랑/검정4점	43	노랑/검정5점																																																																																																																																																																																																																							
4	노랑/빨강1점	14	노랑/빨강2점	24	노랑/빨강3점	34	노랑/빨강4점	44	노랑/빨강5점																																																																																																																																																																																																																							
5	흰색/검정1점	15	흰색/검정2점	25	흰색/검정3점	35	흰색/검정4점	45	흰색/검정5점																																																																																																																																																																																																																							
6	흰색/빨강1점	16	흰색/빨강2점	26	흰색/빨강3점	36	흰색/빨강4점	46	흰색/빨강5점																																																																																																																																																																																																																							
7	흰색/검정1점	17	흰색/검정2점	27	흰색/검정3점	37	흰색/검정4점	47	흰색/검정5점																																																																																																																																																																																																																							
8	흰색/빨강1점	18	흰색/빨강2점	28	흰색/빨강3점	38	흰색/빨강4점	48	흰색/빨강5점																																																																																																																																																																																																																							
9	분홍/검정1점	19	분홍/검정2점	29	분홍/검정3점	39	분홍/검정4점	49	분홍/검정5점																																																																																																																																																																																																																							
10	분홍/빨강1점	20	분홍/빨강2점	30	분홍/빨강3점	40	분홍/빨강4점	50	분홍/빨강5점																																																																																																																																																																																																																							
NO	PIN기능	NO	PIN기능	NO	PIN기능	NO	PIN기능	NO	PIN기능																																																																																																																																																																																																																							
1	TRQCOM	11	PR+	21	SPD3/MODE	31	/BO	41	RDY-																																																																																																																																																																																																																							
2	REFCOM	12	PR-	22	SPD2	32	AO	42	TLOUT																																																																																																																																																																																																																							
3	PZO	13	PCON	23	SPD1	33	/AO	43	ZSPD																																																																																																																																																																																																																							
4	ZO	14	GAIN2(SEN)	24	GND	34	+15V	44	BRAKE																																																																																																																																																																																																																							
5	/ZO	15	PCLEAR	25	GND	35	-15V	45	INSPD/INPOS																																																																																																																																																																																																																							
6	SRO	16	TLIMIT	26	SETCOM	36	GND	46	DIR																																																																																																																																																																																																																							
7	/SRO	17	ALMRST	27	SPDCOM	37	GND	47	SVON																																																																																																																																																																																																																							
8	GND	18	EMG	28	MONIT1	38	ALARM+	48	STOP																																																																																																																																																																																																																							
9	PF+	19	CWLIM	29	MONIT2	39	ALARM-	49	PULCOM																																																																																																																																																																																																																							
10	PF-	20	CCWLIM	30	BO	40	RDY+	50	+24Vin																																																																																																																																																																																																																							
For signal	Communication Cable	APCS-CM5L7U	L7 SERIES	<p>[PC - USB Port] [servoDrive - USB]</p>  <p>11. PC Connection: USB A Plug a. DriveConnection(USB): Mini USB 5P Plug b. Electrical Requirements : 2. Heavy Enclosure, Twisted Pair, EMIfilter-attached type (Reference : SANWA KU-AMB518)</p>																																																																																																																																																																																																																												

Note 6) in the type name box represents the cable type and length: the type/length indications are as follows..

Cable Length(m)	1	2	3	5
Indication	01	02	03	05

■Optional Specifications (connector)

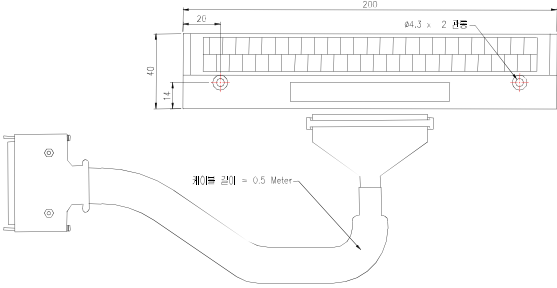
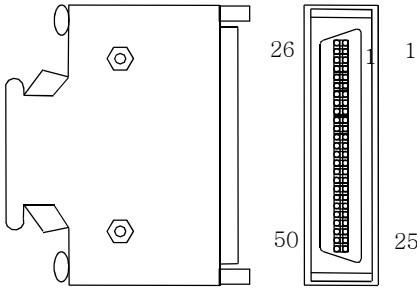
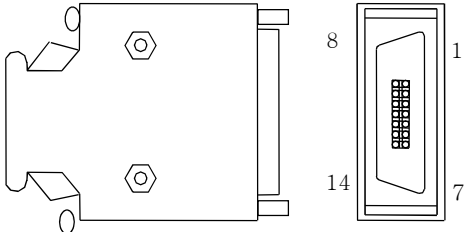
Class ificati on	Product Name	Type Name	Applied Drive	Specifications
T/B	I/O T/B	APC-VSCN1T APC-VPCN1T	L7 SERIES	 <p>12. APC-VSCN1T : CN1 T/B Expansion of APD-VS a. APC-VPCN1T : CN1 T/B Expansion of APD-VS b. Cable Length c. Standard Cable Length : 0.5[m]</p>
CN	I/O Connector	APC-CN1NNA	L7 SERIES	 <p>13. CASE Specifications : 10350-52A0-008(3M) a. CONNECTOR Specifications : 10150-3000VE(3M)</p>
CN	ENCODER Connector	APC-CN3NNA	L7 SERIES	 <p>14. CASE Specifications : 10314-52A0-008(3M) a. CONNECTOR Specifications : 10114-3000VE(3M)</p>

■Optional Specifications(Brake Resistor)

Classification	Product Name	Type Name	Applied Drive	Specifications
Resistor	Brake Resistor	APCS-140R50	L7□A001□ L7□A002□ L7□A004□	
Resistor	Brake Resistor	APCS-300R30	L7□A008□ L7□A010□	
Resistor	Brake Resistor	APC-600R30	L7□A020□ (2P) L7□A035□ (3P)	
Resistor	Brake Resistor	APC-600R28	L7□A050□ (4P)	

17. Commission

For proper and safe commissioning, please check the following in advance. In case of any problem, please take appropriate actions before commissioning.

■ Servo motor status

Was installation and wiring properly performed?

Is there any loose connection?

In case of using a motor with oil chamber, is the oil chamber damaged?

Is oil sprayed?

When commissioning a servo motor after long-term storage, please check the servo motor in accordance with the servo motor repair and checkup instructions. Please see 11. Repair and Checkup for detailed instructions

■ ServoDriveStatus

Was installation, wiring and connection properly performed?

Is the right power voltage supplied to the servodrive?

17.1 Preparation for Operation

Commissioning proceeds in the following order.

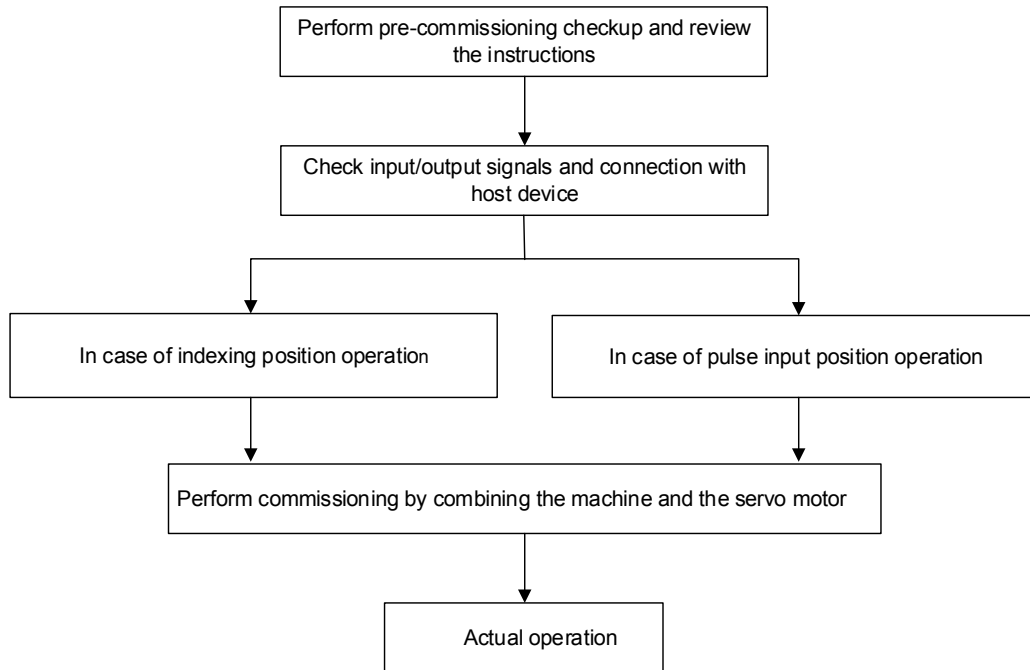

Before commissioning, please check if the host device and the servo drive are properly wired, and the parameter setting of the servo drive is properly done.

When you use Quadrature(Incremental) type motor and other companies' motor, Please, set parameter motor ID [0x2000], Encoder type [0x2001], Encoder Pulse per Revolution and Position error range[0x6065] before testing

17.1.1 Indexing Position Operation

Order	Description	Note
1	Re-check the power and input signal circuit. Turn on the servo drive control power.	
2	Set the Index00~Index63 value in accordance with the index you want to activate.	3.2 Indexing Position Operation
3	For safety, set the speed and registration speed to 1/10 of the values you want to set.	
4	Set the electronic gear ratio to the ratio corresponding to the host device [0x6091].	7.3 Electronic Gear Setting
5	Turn on the servo drive main power.	
6	Set the SVON input signal to ON.	
7	Set the START input signal to ON->OFF.	
8	[0x6062] Check if the distance and registration distance are displayed as the values determined through the position demand value.	
9	[0x6064] Check the actual motor rotation through the position actual value.	
10	Check if the values in Order 8 and 9 satisfy the equation below. [0x6062] = [0x6064] x [0x6091]	
11	Check if the servomotor rotates in the commanded direction and performs indexing operation.	
12	Set the SVON input signal to OFF, change the speed, registration speed to the value you want to set, and repeat the Order 6~11.	
13	Set the SVON input signal to OFF	

17.1.2 Pulse Input Position Operation

■ Commissioning Procedure

Order	Description	Note
1	Re-check the power and input signal circuit. Turn on the servo drive control power.	
2	Set the [0x3003] input pulse logic in accordance with the pulse output of the host device	5.1 Pulse Input LogicFunction Setting
3	Set the command unit, and set the [0x6091] gear ratio to the ratio corresponding to the host device.	7.3 Electronic Gear Setting
4	Turn on the servo drive main power.	
5	Set the SVON input signal to ON.	
6	Output a low-speed pulse command at the host device, at a motor rotation that is easy to confirm. Please set the command pulse speed to 100[rpm] or below, for safety.	
7	[0x6062] check the number of command pulses input through the position demand value.	
8	[0x6064] check the actual motor rotation through the position actual value.	
9	Check if the values in Order 7 and 8 satisfy the equation below. $[0x6062] = [0x6064] \times [0x6091]$	
10	Check if the servomotor rotated in the commanded direction.	
11	Output the pulse command at the host device at the speed required by the equipment.	
12	Check the servomotor speed, position demand value and position actual value.	
13	Stop the pulse command, and set the SVON input signal to OFF.	

17.2 Examples of Connection with Host Device (Pulse Input Position)

17.2.1 Connection with LSIS XGF-PD1/2/3A

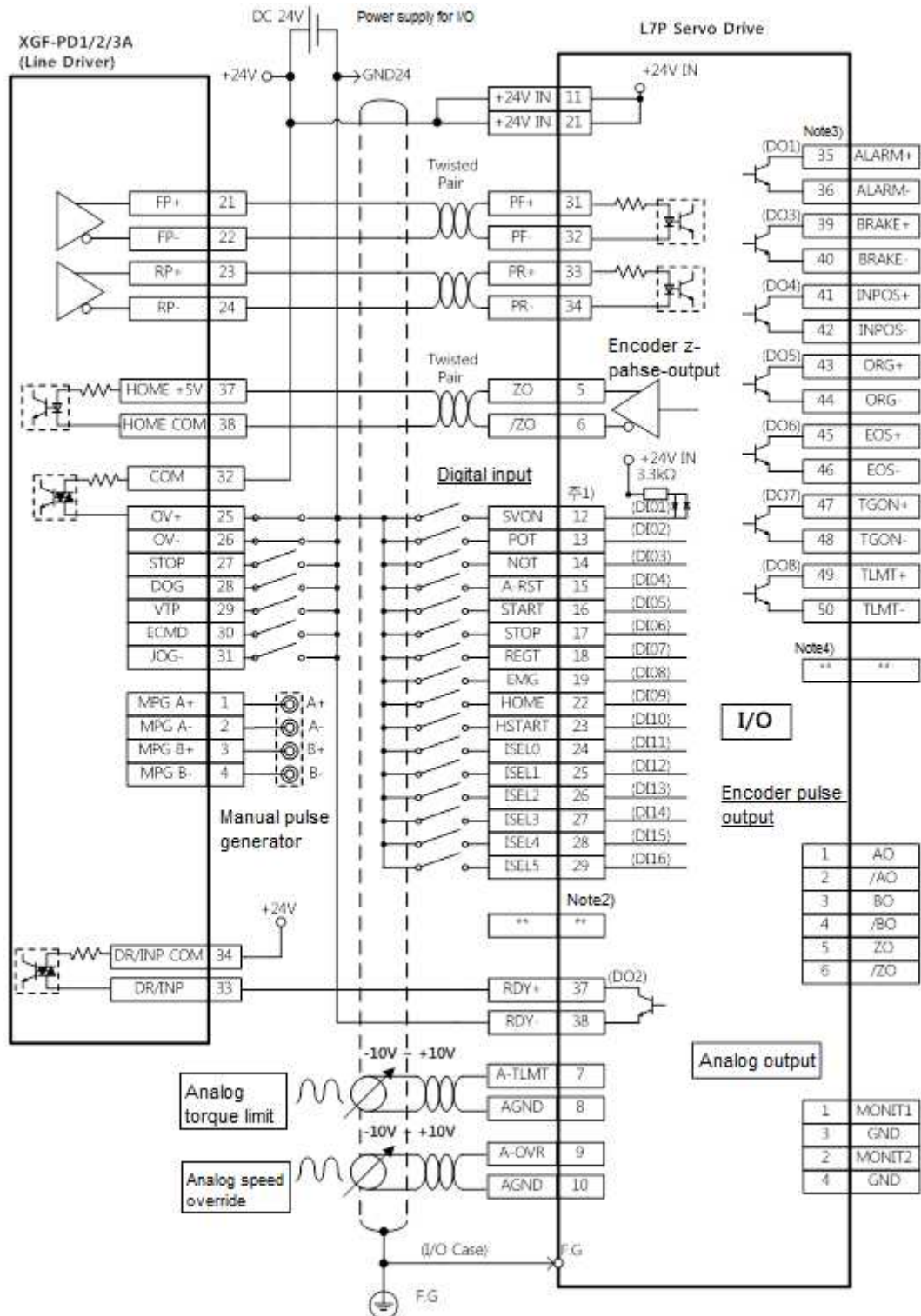

17.2.2 Connection with LSIS XGF-PO1/2/3A

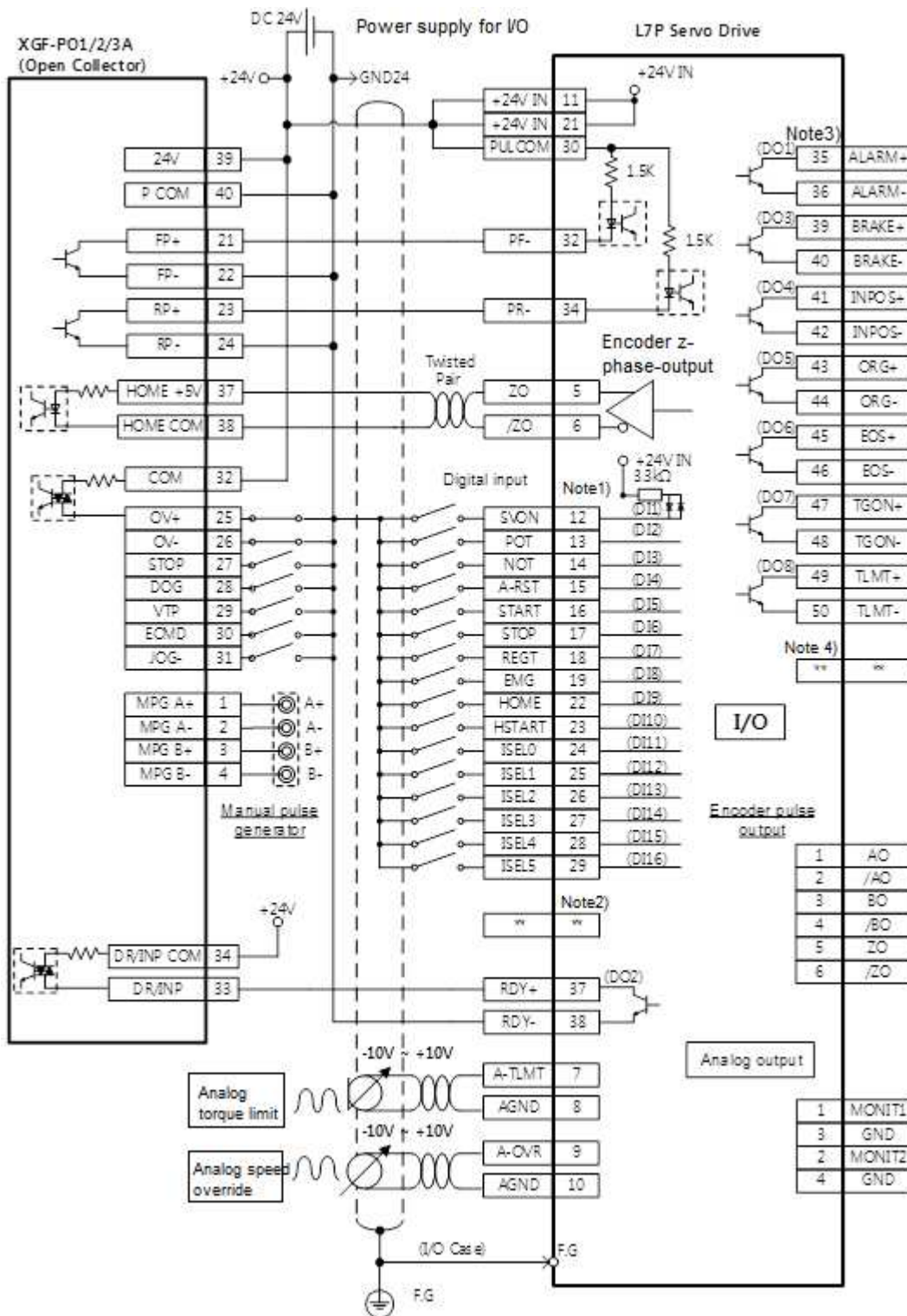

17.2.3 Example of Connection with XGF-PD1/2/3H of LSIS

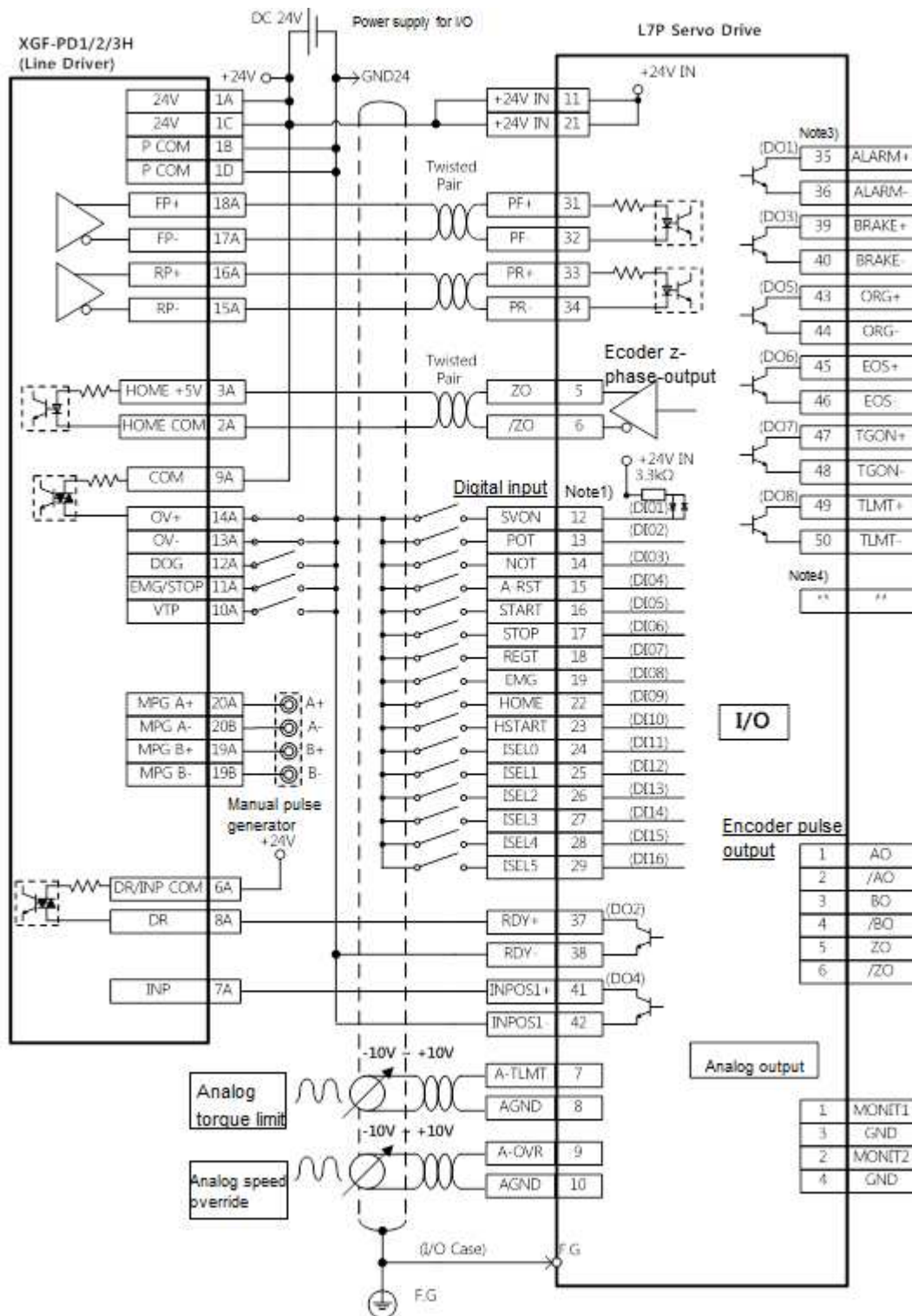

17.2.4 Example of Connection with XGF-PO1/2/3H of LSIS

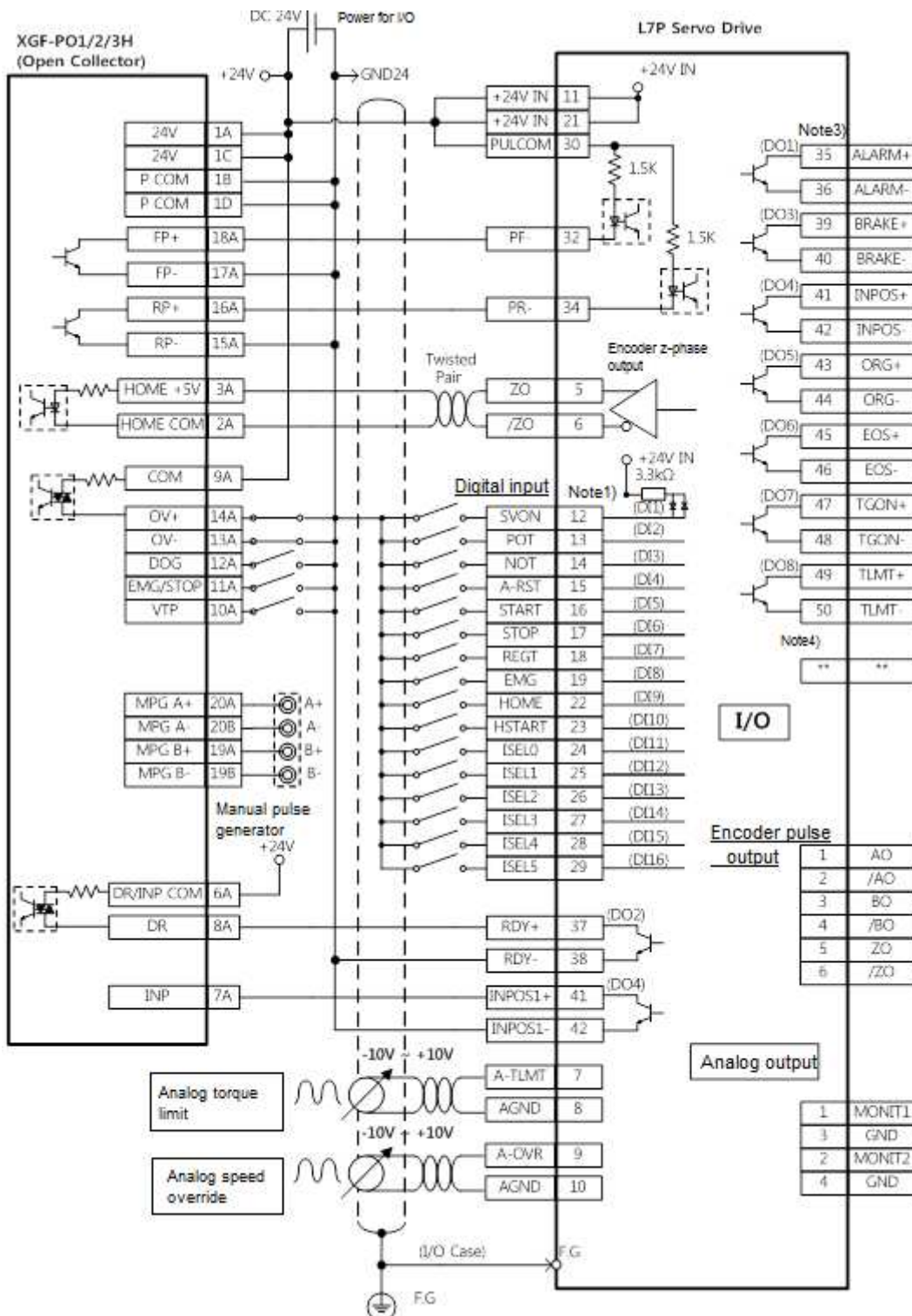

18. Appendix

18.1 Firmware Update

18.1.1 Using USB OTG

The drive functions as the USB host, which searches for any firmware files in the USB memory, and download it into the flash memory in the drive. Using this function, you can conveniently update the drive firmware using only the USB memory and OTG cable, without going through the PC. The update procedure is as follows.

- (1) Prepare a download Cable(USB OTG Cable) and USB memory.

Use USB OTG Cable consisting (USB Female Plug Type A, USB Mini B 5pin) as the download cable.



- (2) Copy the firmware file to update (L7P_FW.bin) into the USB memory

***Caution– USB memory has to be formatted “FAT32” and the L7P_FW.bin file should be put into the root directory of the USB memory. And the file name, including the extension should match the name indicated here. (You don’t need to classify capital and small letter in file name)**

- (3) Connect the USB memory to the USB OTG Cable, connect the cable to the drive’s USB terminal, and turn on the drive.

- (4) If the 7-segment for servo status displays ‘boot’ and then ‘otg’, this means the firmware is being updated. When the ‘otg’ display disappears, it means the firmware download is complete, at which time you can remove the USB cable and the USB.

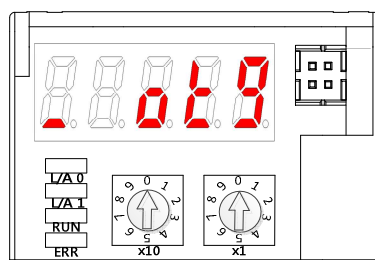

(7-Segment display for firmware update using OTG cable)

(5) Turn on the power again, and then check if the firmware update is applied.

18.1.2 Using Drive CM

Using 'Drive CM', you can upgrade the drive OS to the latest version through the USB port of your PC. The transmission time varies depending on the PC's performance, from tens of seconds to a few minutes.



Figure3-13

Click 'FIRMWARE UPGRADE' → 'OS Download' at the menu on the top.

■ Instructions fo Firmware Upgrade

- Do not turn off the PC or drive during transmission.
- Do not unplug the USB cable or close the firmware program during transmission.
- Do not run other PC applications during transmission.

■ OS Download Action

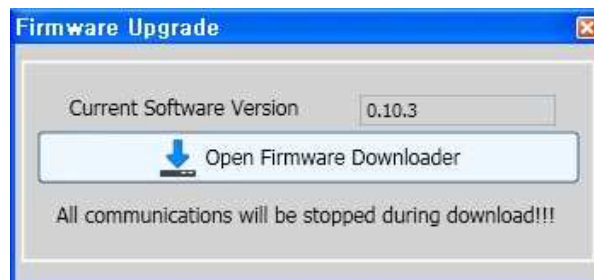

Figure 3-13.1

(1) Click the 'Open Firmware Downloader' button.

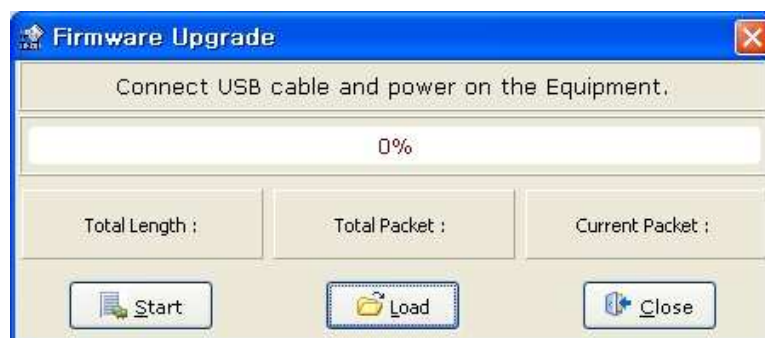

Figure3-13.2

(2) Click the 'Load' button to load the OS.

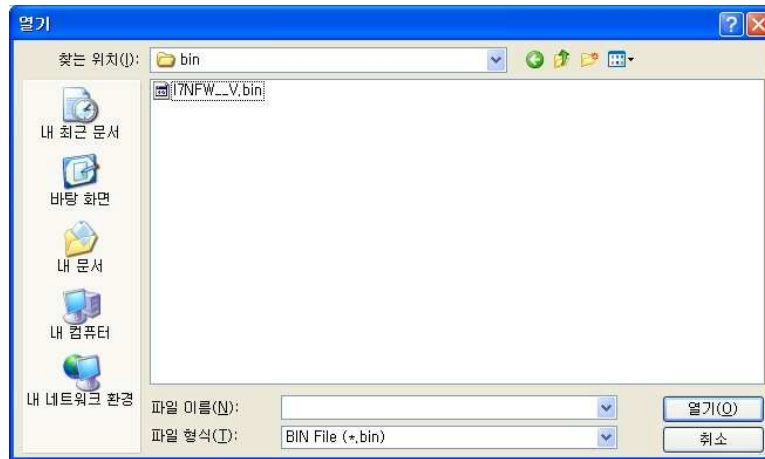

Figure3-13.3

(3) Click the 'BIN' file of the OS to transmit, and then click 'Open.'

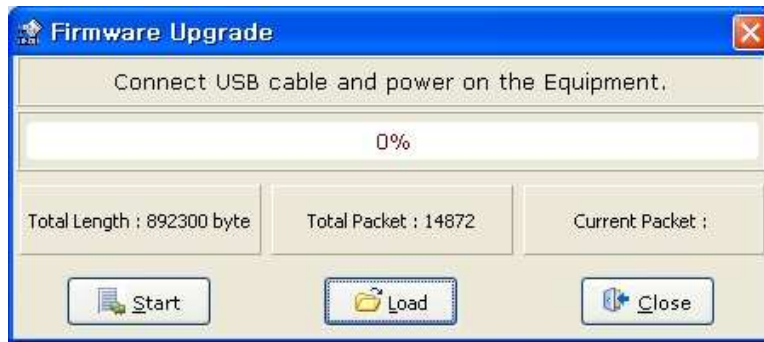

Figure3-13.4

(4) The 'Total Length', 'Total Packet' of the loaded OS are displayed.

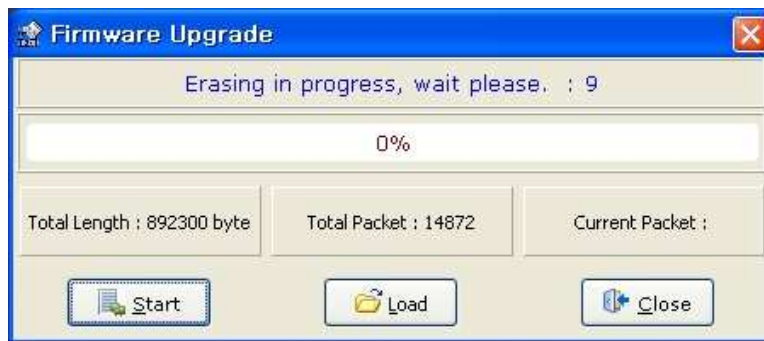

Figure3-13.5

(5) Click 'Start' to begin transmission. The system decounts 10 seconds while it clears the drive's internal memory (at this time, in case of Drive L7NH, L7P, the 7-segment should display 'USB". In case of PEGASUS, the 'ERR" red LED should be on.)

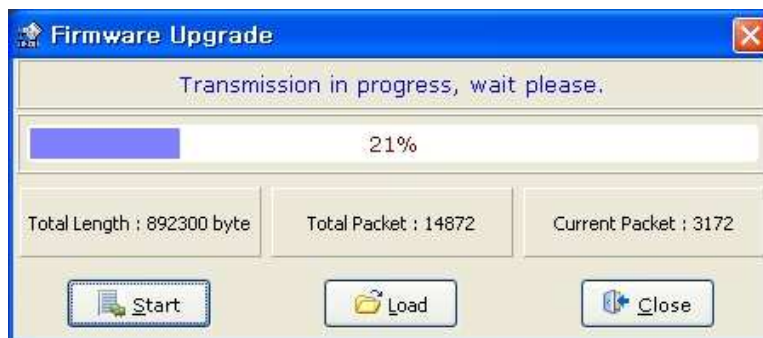

Figure 3-13.6

(6) The OS is automatically transmitted after the memory is cleared. You can see the current progress through the progress bar and 'current packet.' (삭제완료후 OS 가자동전송되며, 프로그레스바와 'Current Packet'.(The transmission time varies depending on the PC's performance, from tens of seconds to a few minutes.)



Figure3-13.7

(7) 'Transmission completed' window pops up when the transmission is properly completed (after transmission, turn off and on the drive to reboot it.)

■ **When an error occurs during transmission**



Figure 3-13.8

(1) Turn off and on the drive, and then repeat through (2) to (7).