

LE4S Series

DIN W48×H48mm Digital backlight LCD timer

■ Features

○ Upgraded Features

- Mounting space saving with compact design
: downsized by approx. 22% in depth compared to existing models
(length of panel on the back side is 56mm)
- Available to set each value and time range separately when choosing Flicker(FK, FK I) or ON-OFF Delay(ON OFF D, ON OFF D I) output mode
- Adds Flicker 1 mode(LE4SA)
- Settable One-shot output time(0.01 to 99.99sec.)
(existing model: fixed 0.5 sec.)
- Configurable time range (added 9.999sec.): Settable by 0.001sec. unit
- Selectable min. input time: 1ms or 20ms (LE4S)
- Improved return time: 100ms
- Backlight ON/OFF function

○ Original Features

- Wide time range(0.01sec. to 9999hour)
- Lock setting function for saving setting data
- Soft touch setting
- High visibility display with backlight



⚠ Please read "Caution for your safety" in operation manual before using.



■ Ordering information

LE	4	S		
Item	Digit	Size	Output	
				No mark Time-limit contact 1c
				A Time-limit contact 2c, Time-limit contact 1c+Instantaneous contact 1c(selectable)
				S DIN W48×H48mm
				4 9999(4digit)
				LE LCD Timer

■ Specifications

※Sockets (PG-08, PS-08, PS-M08) are sold separately.

Model		LE4S	LE4SA
Function		Multi time and Multi operation	
Display method		LCD display(Backlight)	
Power supply		24-240VAC 50/60Hz, 24-240VDC universal	
Allowable voltage range		90 to 110% of rated voltage	
Power consumption		Max. 4.5VA(24-240VAC 50/60Hz), Max. 2W(24-240VDC)	Max. 4VA(24-240VAC 50/60Hz), Max. 1.6W(24-240VDC)
Return time		Max. 100ms	
Min. input signal	START	1ms, 20ms(selectable)	—
	INHIBIT		
	RESET		
Input	START	• No-voltage input Impedance at short-circuit : Max. 1kΩ, Residual voltage : Max. 0.5V, Impedance at open-circuit : Min. 100kΩ	—
	INHIBIT		
	RESET		
Timing operation		Signal ON Start	Power ON Start
Control output	Contact type	Time limit SPDT(1c)	Selectable Time limit DPDT(2c), Time limit SPDT(1c)+ Instantaneous SPDT(1c) (depends on operation mode)
	Contact capacity	250VAC 5A resistive load	250VAC 3A resistive load
Relay life cycle	Mechanical	Min. 10,000,000 operations	
	Electrical	Min. 100,000 operations (at rated contact capacity)	
Output mode		10 operation modes	8 operation modes
Environ-ment	Ambient temperature	-10 to 55°C, storage: -25 to 65°C	
	Ambient humidity	35 to 85%RH	
Accessory		Bracket	

※Environment resistance is rated at no freezing or condensation.

LCD Timer(Touch Type)

Specifications

Model	LE4S	LE4SA
Repeat error	Max. $\pm 0.01\%$ $\pm 0.05\text{sec.}$ (Power ON Start) Max. $\pm 0.005\%$ $\pm 0.03\text{sec.}$ (Signal ON Start)	Max. $\pm 0.01\%$ $\pm 0.05\text{sec.}$
Setting error		
Voltage error		
Temperature error		
Insulation resistance	100M Ω (at 500VDC megger)	
Dielectric strength	2000VAC 50/60Hz for 1 minute	
Noise strength	$\pm 2\text{kV}$ the square wave noise(pulse width: 1 μs) by the noise simulator	
Vibration	Mechanical	0.75mm amplitude at frequency of 10 to 55Hz(for 1 min.) in each of X, Y, Z directions for 1hour
	Malfunction	0.5mm amplitude at frequency of 10 to 55Hz(for 1 min.) in each of X, Y, Z directions for 10 minutes
Shock	Mechanical	300m/s ² (approx. 30G) in each of X, Y, Z directions for 3 times
	Malfunction	100m/s ² (approx. 10G) in each of X, Y, Z directions for 3 times
Approval	CE c  us	
Unit weight	Approx. 98g	

Dimensions

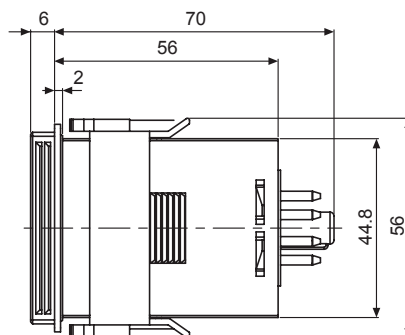
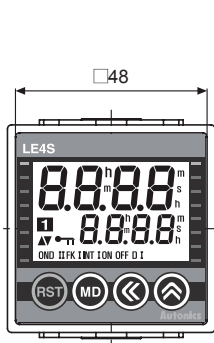

Panel cut-out

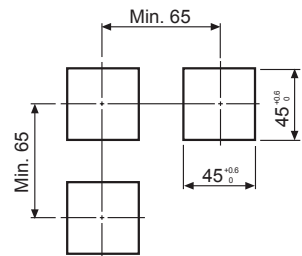

Bracket and mounting

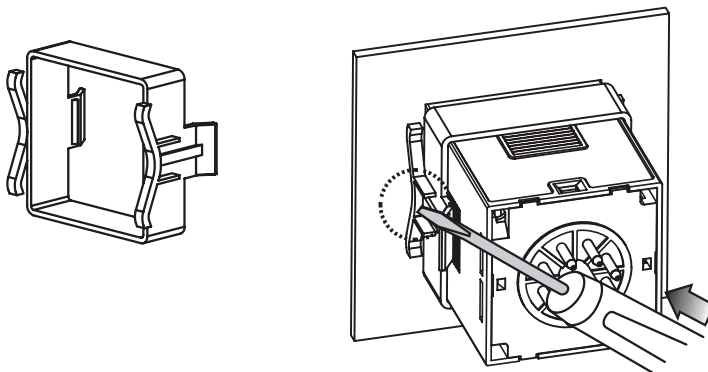

※Insert product into a panel, fasten bracket by pushing with tools as shown above.

(A) Photo electric sensor

(B) Fiber optic sensor

(C) Door/Area sensor

(D) Proximity sensor

(E) Pressure sensor

(F) Rotary encoder

(G) Connector/Socket

(H) Temp. controller

(I) SSR/ Power controller

(J) Counter

(K) Timer

(L) Panel meter

(M) Tacho/ Speed/ Pulse meter

(N) Display unit

(O) Sensor controller

(P) Switching mode power supply

(Q) Stepper motor& Driver&Controller

(R) Graphic/ Logic panel

(S) Field network device

(T) Software

(U) Other

LE4S Series

■ Connections

○ LE4S

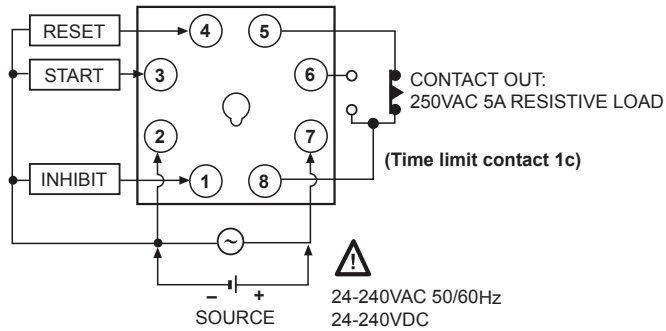

○ LE4SA

● [ON.D] [ON.D.II] [FK] [FKI] [INT] [T] [T.I] mode

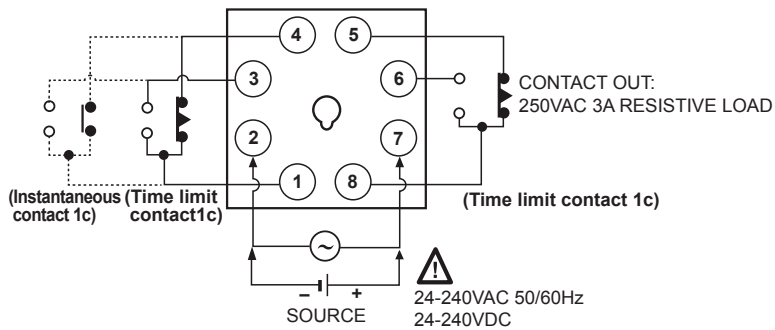

※Time limit contact 1c + Instantaneous contact 1c or Time limit contact 2c (Selectable)
([T] [T.I] : Time limit 2c only.)

● [λ-Δ] mode

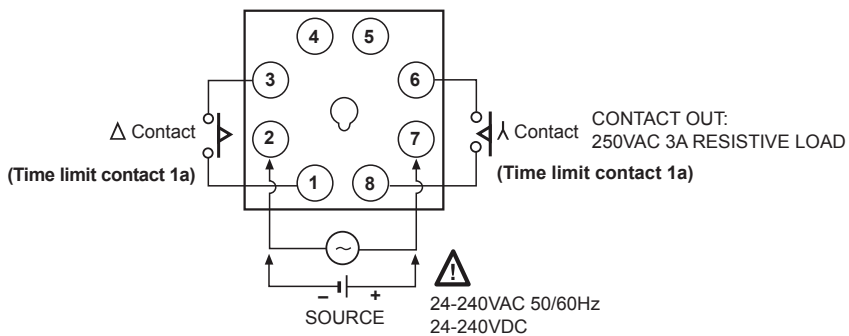

LCD Timer(Touch Type)

Input connections

LE4S is No-voltage input(Short-circuit and open) type.

● Solid-state input

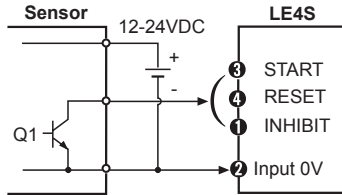

- Q1 is ON : Operating
- Sensor : NPN open collector output

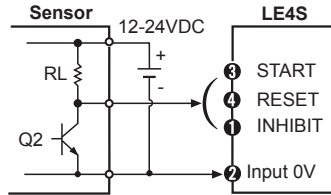

- Q2 is ON : Operating
- Sensor : NPN universal output

● Contact input

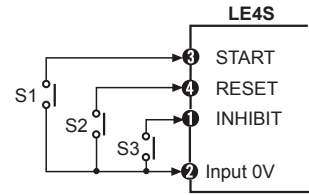

- S1, S2, S3 are ON : Operating
- Please use reliable contact enough to flow 5VDC 1mA.

※Be sure that it is not insulated between power and input terminal block.

Parts description

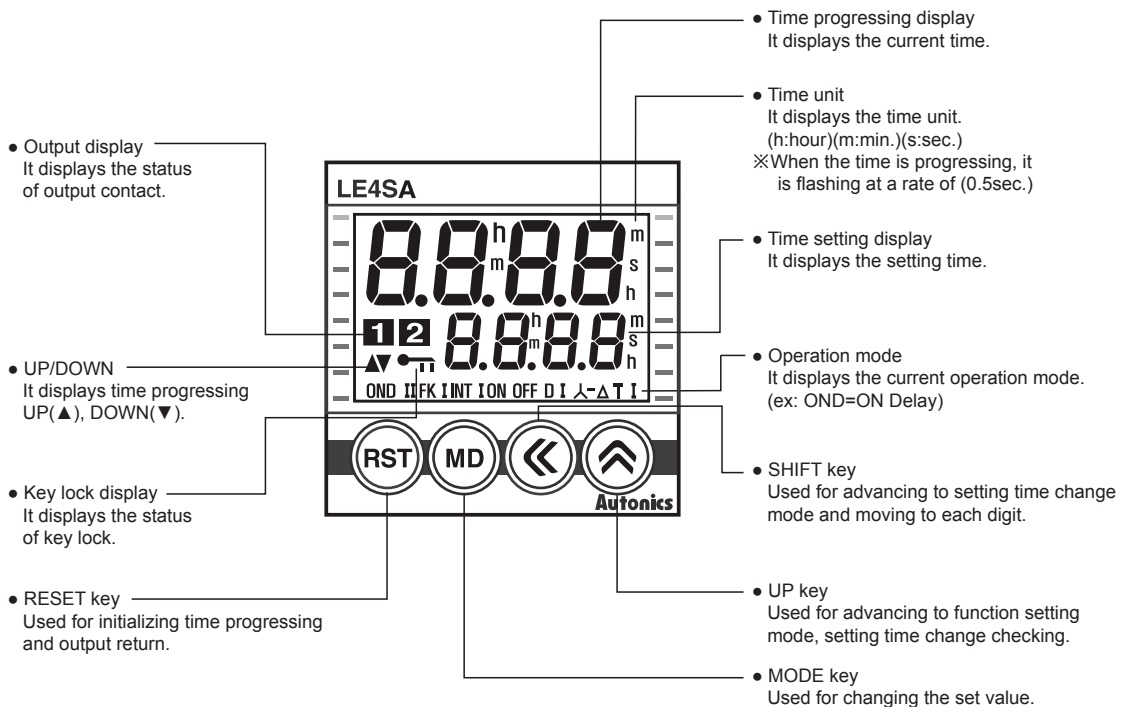

(A) Photo electric sensor

(B) Fiber optic sensor

(C) Door/Area sensor

(D) Proximity sensor

(E) Pressure sensor

(F) Rotary encoder

(G) Connector/Socket

(H) Temp. controller

(I) SSR/Power controller

(J) Counter

(K) Timer

(L) Panel meter

(M) Tacho/Speed/ Pulse meter

(N) Display unit

(O) Sensor controller

(P) Switching mode power supply

(Q) Stepper motor& Driver&Controller

(R) Graphic/ Logic panel

(S) Field network device

(T) Software

(U) Other

LE4S Series

■ Function and time setting

◎ Configuration

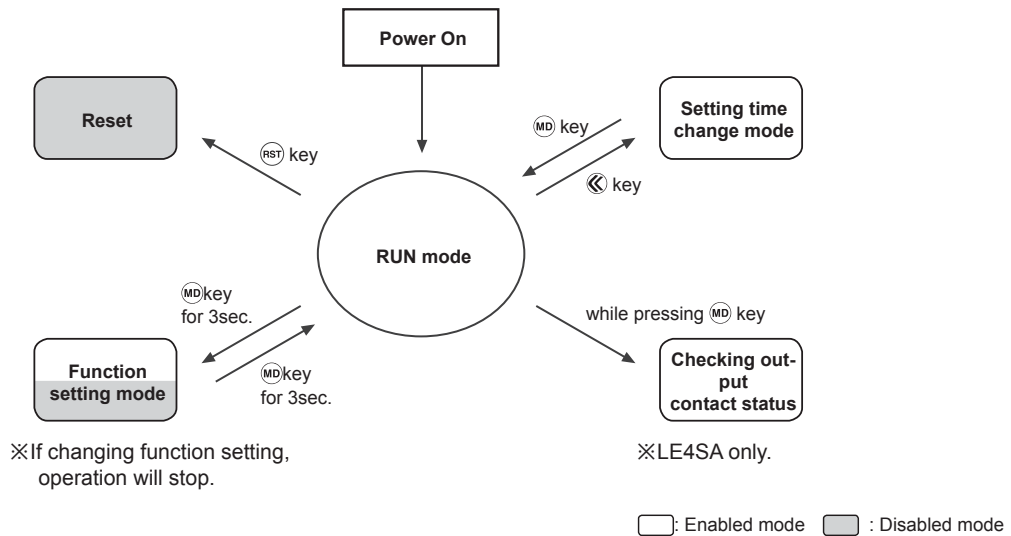

● Reset

Reset using **(RST)** key in Run mode

● Run mode

The operation status(When power is on for the first time : factory default setting) is displayed.
It could enter into function setting mode, setting value change mode and output contact status mode.

● Function setting mode

If pressing **(MD)** key over 3 sec. in the Run mode, it will enter into function setting mode and if pressing **(MD)** key over 3 sec. in function setting mode, it will return to Run mode.

※Even if it enter into function setting mode in Run mode, time progressing and output control will continue.

※If operation settings are changed in function setting mode, all outputs will be off and reset on returning to run mode.

● Output contact status mode(LE4SA only)

Output contact status are displayed while pressing **(MD)** key in Run mode.

※If pressing **(MD)** key over 3 sec., it will enter into function setting mode.

● Setting time change mode

Press **(◀)** key to enter into setting time change mode and press **(MD)** key to return to Run mode.

Even if signal is input when changing setting time, time progressing and output control will be continue.

If no key is pressed over 60 sec. in setting time change mode, it will return to Run mode.

※If no key is pressed over 60 sec. in setting time change mode, it will return to Run mode and previous parameter value is not stored.

LCD Timer(Touch Type)

Function setting mode

LE4S

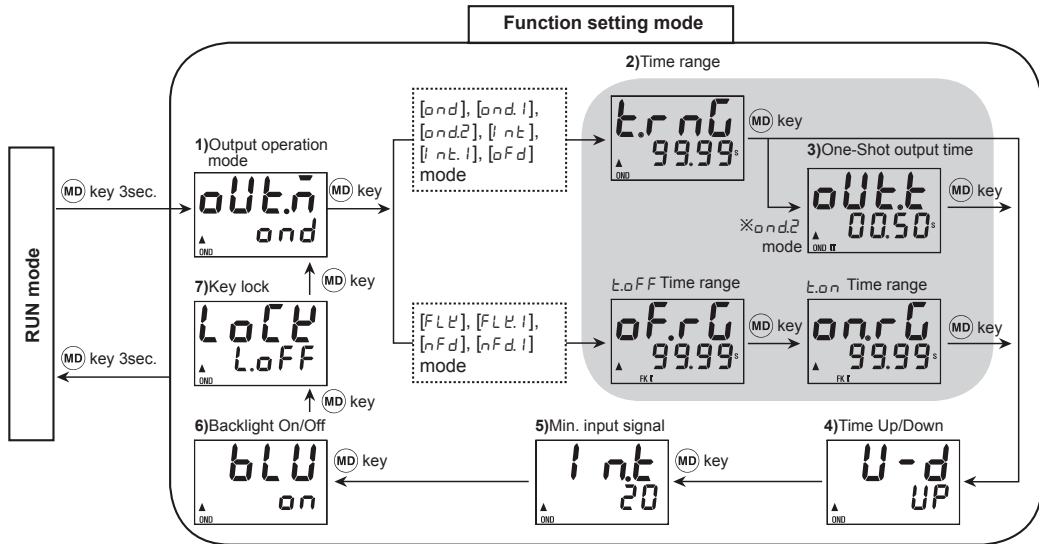

LE4SA

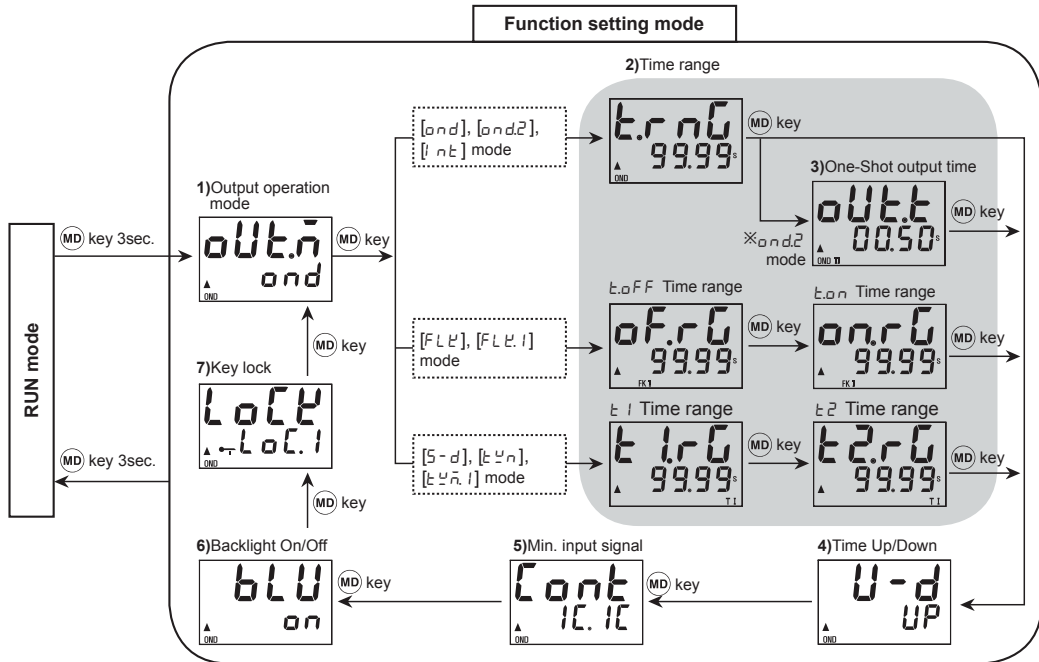

Factory default

LE4S

Parameter	Current Value	Factory default
Output operation mode	<code>oUt.n</code>	<code>ond</code>
Time range	<code>t.rnG</code>	<code>99.99</code>
Time Up/Down	<code>U-d</code>	<code>UP</code>
Min. input signal	<code>I nt</code>	<code>20</code>
Backlight On/Off	<code>bLU</code>	<code>on</code>
Key lock	<code>LoCK</code>	<code>L.oFF</code>
Setting time	—	<code>50.00</code>

LE4SA

Parameter	Current Value	Factory default
Output operation mode	<code>oUt.n</code>	<code>ond</code>
Time range	<code>t.rnG</code>	<code>99.99</code>
Time Up/Down	<code>U-d</code>	<code>UP</code>
Output contact	<code>Cont</code>	<code>1C.1C</code>
Backlight On/Off	<code>bLU</code>	<code>on</code>
Key lock	<code>LoCK</code>	<code>L.oC.1</code>
Setting time	—	<code>50.00</code>

- (A) Photo electric sensor
- (B) Fiber optic sensor
- (C) Door/Area sensor
- (D) Proximity sensor
- (E) Pressure sensor
- (F) Rotary encoder
- (G) Connector/ Socket
- (H) Temp. controller
- (I) SSR/ Power controller
- (J) Counter
- (K) Timer
- (L) Panel meter
- (M) Tacho/ Speed/ Pulse meter
- (N) Display unit
- (O) Sensor controller
- (P) Switching mode power supply
- (Q) Stepper motor& Driver&Controller
- (R) Graphic/ Logic panel
- (S) Field network device
- (T) Software
- (U) Other

LE4S Series

■ Output operation mode

● LE4S/LE4SA output operation mode

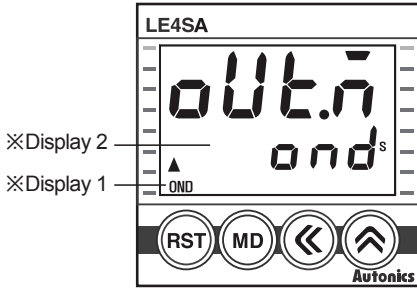

NO	※Display 1	※Display 2	Operation mode	LE4S	LE4SA
1	OND	ond	ON Delay	○	○
2	ONDI	ond.1	ON Delay 1	○	—
3	ONDI2	ond.2	ON Delay 2	○	○
4	FK	FLY	Flicker	○	○
5	FKI	FLY.1	Flicker 1	○	○
6	INT	int	Interval	○	○
7	INT1	int.1	Interval 1	○	—
8	ON OFF D	nFd	ON-OFF Delay	○	—
9	ON OFF DI	nFd.1	ON-OFF Delay 1	○	—
10	OFF D	oFd	OFF Delay	○	—
11	λ-Δ	S-d	STAR-Delay	—	○
12	T	tyn	Twin	—	○
13	TI	tyn.1	Twin 1	—	○

● Output operation mode

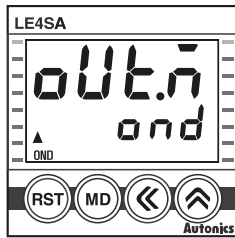

[Fig.1]

- 1) In function setting mode, it enter into output operation mode as shown in the [Fig. 1].
- 2) Select proper output operation mode using ◀ and ▶ key.
(Refer to Output operation flowchart)
- 3) Press MD key to set output operation mode and move to next mode.
- 4) If pressing MD key for 3 sec. in any function setting mode, it will return to Run mode.

※Output operation flowchart

< LE4S >

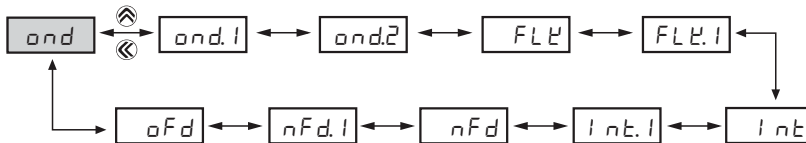

< LE4SA >

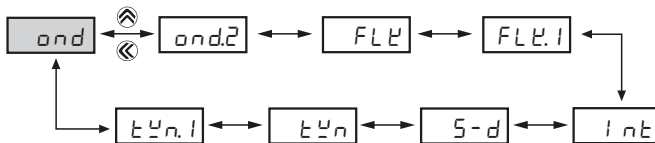

※The shaded parameter() is factory default.

■ Time Range

• Time range specifications

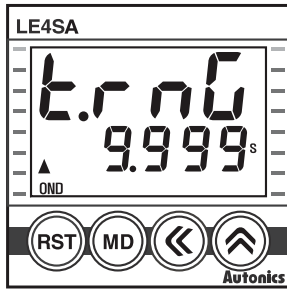

Parameter	Time range specification
9999 s (9.999s)	0.010sec. to 9.999sec.
9999 s (99.99s)	0.01sec. to 99.99sec.
9999 s (999.9s)	0.1sec. to 999.9sec.
9999 s (9999s)	1sec. to 9999sec.
99m59 s (99m59s)	0m01sec. to 99min. 59sec.
999.9 m (999.9m)	0.1min. to 999.9min.
9999 m (9999m)	1min. to 9999min.
99h59m (99h59m)	0h01min. to 99hour 59min.
9999 h (99.99h)	0.01hour to 99.99hour
9999 h (999.9h)	0.1hour to 999.9hour
9999 h (9999h)	1hour to 9999hour

t.oFF time range

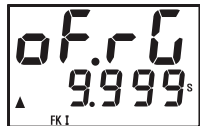

t.oN time range



t.1 time range

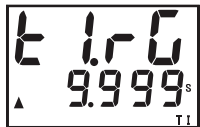

t.2 time range



※Time range according to output operation mode

- Time range[t.r.n.G]
- : ond, ond.1, ond2, 1nt, 1nt.1, oFd mode
- t.oFF/t.oN time range[o.F.r.G/o.n.r.G]
- : FLt, FLt.1, nFd, nFd.1 mode
- t.1/t.2 time range[t.1.r.G/t.2.r.G]
- : S-d, tYn, tYn.1 mode

• Time range selection method

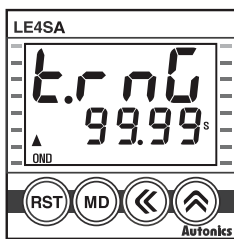

[Fig.1]

When ond, ond.1, ond2, 1nt, 1nt.1, oFd mode

- 1) In function setting mode, if enter into time range mode, the characters will be displayed as shown in the [Fig. 1].
- 2) Select the time range using ⏪ and ⏩ key.
(Refer to time range flowchart)
- 3) Press ⏸ key to complete the time range setting and the next mode.
- 4) If pressing ⏸ key for 3 sec., it will return to Run mode.

※When FLt, FLt.1, nFd, nFd.1, S-d, tYn, tYn.1 time range[t.1.r.G, t.2.r.G or o.F.r.G, o.n.r.G] can be individually set.

※Time range flowchart

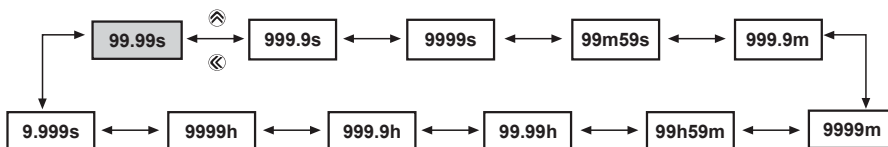

※The shaded parameter() is factory default.

(A)	Photo electric sensor
(B)	Fiber optic sensor
(C)	Door/Area sensor
(D)	Proximity sensor
(E)	Pressure sensor
(F)	Rotary encoder
(G)	Connector/Socket
(H)	Temp. controller
(I)	SSR/ Power controller
(J)	Counter
(K)	Timer
(L)	Panel meter
(M)	Tacho/ Speed/ Pulse meter
(N)	Display unit
(O)	Sensor controller
(P)	Switching mode power supply
(Q)	Stepper motor& Driver&Controller
(R)	Graphic/ Logic panel
(S)	Field network device
(T)	Software
(U)	Other

• One-shot output time setting

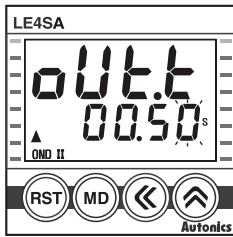

[Fig.2] ※Factory default

When output operation mode ON Delay 2[*o n d 2*],

- 1) In function setting mode, if it enter into One-shot output time setting mode as shown in the [Fig. 2], the last digit will flash.
- 2) Set One-shot output time using \leftarrow and \rightarrow key.(setting range: 0.01s to 99.99s)
- 3) Pressing MD key to complete one-shot output time setting and move to the next mode.
- 4) If pressing MD key for 3 sec. in any function setting mode, it will return to Run mode.

• Time progress UP/DOWN setting

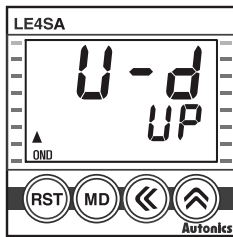

[Fig.3]※Factory default

- 1) In function setting mode, if it advances to UP/DOWN setting mode, the characters will be displayed as shown in the [Fig. 3].
- 2) Select *UP* (\blacktriangle), *dn* (\blacktriangledown) using \leftarrow , \rightarrow key.



- 3) Press MD key to complete UP/DOWN setting and move to the next mode.
- 4) If pressing MD key for 3sec. in any function setting mode, it will return to Run mode.

• The minimum input signal setting(LE4S only)

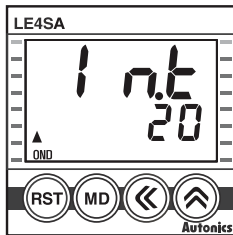

[Fig.4]
※Factory default

RESET, START and INHIBIT.

- 1) In function setting mode, if it enter into input signal setting mode, the characters will be displayed as shown in the [Fig. 4].
- 2) Select 1ms or 20 ms using \leftarrow , \rightarrow keys.



- 3) Press MD key to complete input signal width and move to the next mode.
- 4) If Pressing MD key over 3 sec. in any function setting mode, it will return to Run mode.

• Output contact setting(LE4SA only)

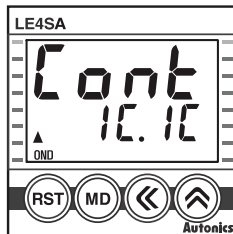

[Fig.5]
※Factory default

- 1) In function setting mode, if it enter into output contact setting mode, the characters will be displayed as shown in the [Fig. 5].

2)Select time limit 1c+instant limit 1c or time limit 2c using \leftarrow , \rightarrow keys.
(Refer to LE4SA Connections on K-20 page for output contact connections)



- 3) Press MD key to complete output contact setting and move to the next mode.
- 4) If pressing MD key for 3 sec. in any function setting, it will return to Run mode.
※Except for Star-Delta, Twin and Twin 1 modes(2c is set automatically)
※If pressing MD key in Run mode, output contact setting value will be displayed.
(If no key is pressed over 3 sec., it will enter into function setting mode.)

● Backlight ON/OFF setting

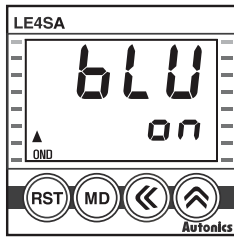

[Fig.6]

※Factory default

1) In function setting mode, if enter into Backlight ON/OFF setting mode, the characters will be displayed as shown in the [Fig. 6].

2) Select Backlight on or off using \leftarrow , \rightarrow key.



3) Press MD key to complete Backlight ON/OFF setting and move to the next mode.

4) If pressing MD key for 3 sec. in any function setting mode, it will return to Run mode.

● Key Lock setting

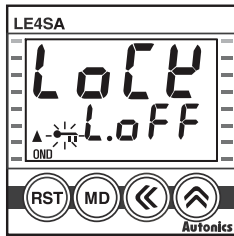

[Fig.7]

※Factory default

1) In function setting mode, if enter into Key Lock setting mode, the characters will be displayed as shown in the [Fig. 7].

2) Select $LoFF$, $LoC.1$, $LoC.2$ or $LoC.3$ using \leftarrow , \rightarrow key.

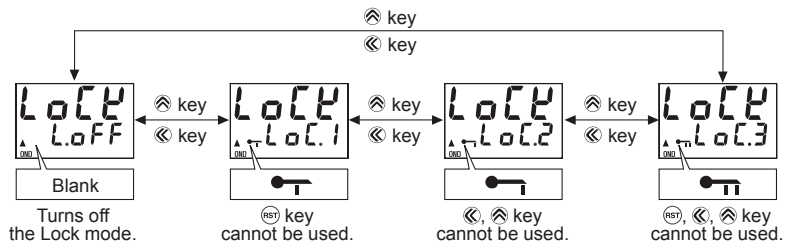

3) Press MD key to complete key lock setting and move to the next mode.

4) If pressing MD key for 3 sec. in any function setting mode, it will return to Run mode.

※Factory default for LE4S is $LoFF$ and Factory default for LE4SA is $LoC.1$.

※Key Lock function

Display	Function
$LoFF$	Turns off the key Lock mode.
$LoC.1$	RST key cannot be used.
$LoC.2$	\leftarrow , \rightarrow key cannot be used.
$LoC.3$	RST , \leftarrow , \rightarrow key cannot be used.

■ Setting time change

Please set operation time according to following instruction as the setting is different depending on the output operation mode.

● Output operation mode : OND, ONDI, ONDI, INT, INTI, OFF D

(LE4SA does not have no ONDI, INTI, OFF D.)

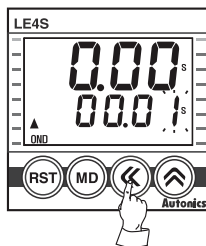

[Fig.1]

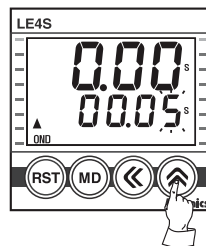

[Fig.2]

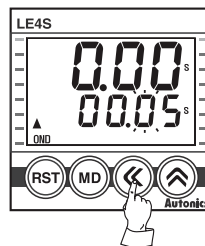

[Fig.3]

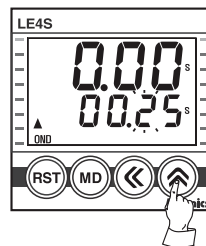

[Fig.4]

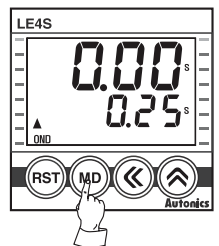

[Fig.5]

1) Press \leftarrow key in RUN mode, time set digits will flash.[Fig. 1]

2) Change setting time by using \leftarrow or \rightarrow key.[Fig. 2,3,4]

- \leftarrow key : Shift the setting digits.

- \rightarrow key : Shift the flashing position value. As press \rightarrow key once, it will increase by 1digit, number will increase faster by press \rightarrow key for over 2sec.

3) When the setting is completed, it will be stored and return to RUN mode by pressing MD key.[Fig. 5]

(A) Photo electric sensor

(B) Fiber optic sensor

(C) Door/Area sensor

(D) Proximity sensor

(E) Pressure sensor

(F) Rotary encoder

(G) Connector/Socket

(H) Temp. controller

(I) SSR/Power controller

(J) Counter

(K) Timer

(L) Panel meter

(M) Tacho/Speed/ Pulse meter

(N) Display unit

(O) Sensor controller

(P) Switching mode power supply

(Q) Stepper motor& Driver&Controller

(R) Graphic/Logic panel

(S) Field network device

(T) Software

(U) Other

LE4S Series

• Output operation mode : FK, FK I

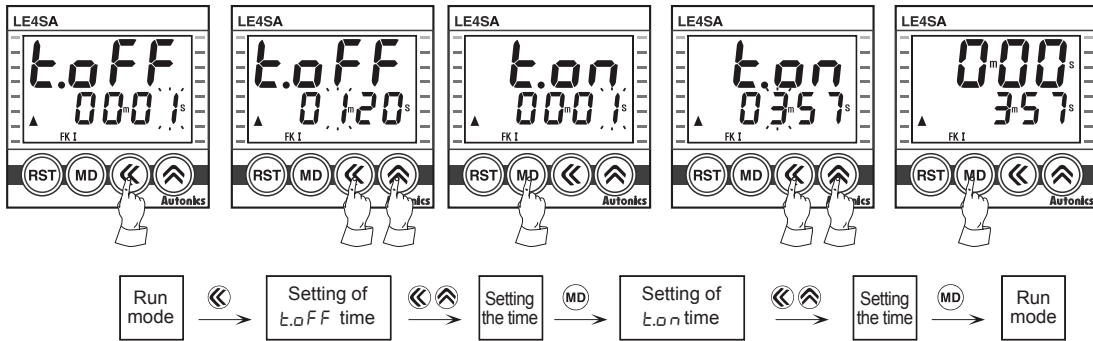

• Output operation mode : ON OFF D, ON OFF D I (LE4S only)

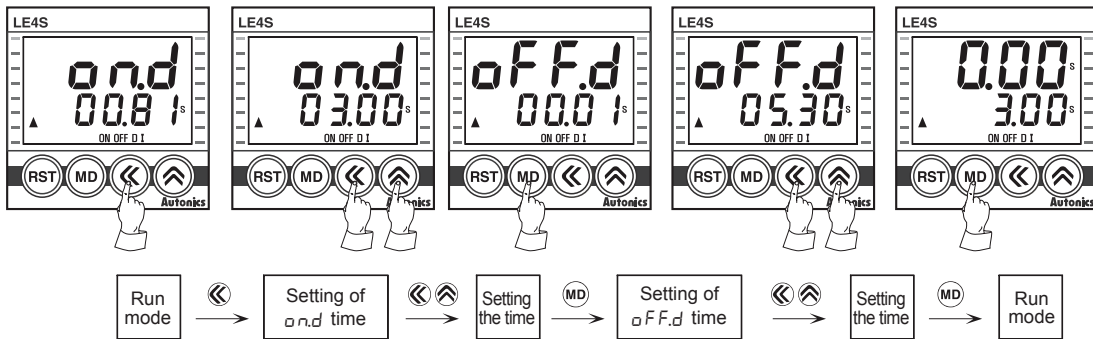

• Output operation mode : λ - Δ , T, TI (LE4SA only)

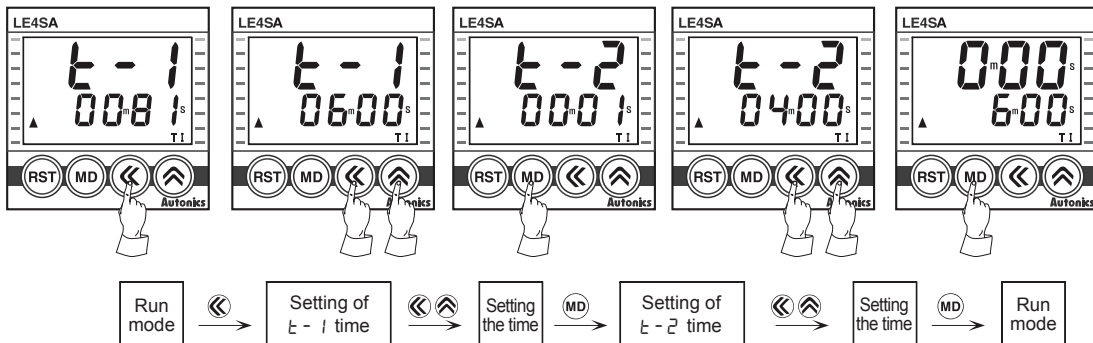

- ※ It is able to change the setting time during the time progressing, but be sure about the time progressing while changing of the time.
- ※ If pressing MD key while setting time is shorter than min. setting time, setting value will be flickering three times and it will be returned to setting mode again, not to RUN mode.
- ※ If there is no additional key operations in 60 sec. after entering into setting mode, it will be return to RUN mode. (set value is not stored.)
- ※ Min. setting time : 0.01 sec.
(In case of : $o.n.d$, $o.n.d.1$, $o.n.d.2$ modes, it is able to set "0" since no min. setting time is applied.)

LCD Timer(Touch Type)

LE4S Output operation mode

T = Setting time, T > Ta

Mode	Time chart	Operation
[OND]		<p>T = set time</p>
OND		
ON Delay	<ol style="list-style-type: none"> Timing operation starts when START signal is ON at status of power on. Output will be ON when timing operation is progressed up to the setting time. Display value will be HOLD. (⓪ position) When RESET signal is ON, display value and output will be reset. (Ⓛ position) If RESET signal is OFF while START signal is ON, "STEP 1" will be restarted. (Ⓜ position) When START signal is OFF, display value and output will be reset. (Ⓨ position) 	
T > Ta		
[OND.1]		<p>T = set time</p>
ONDI		
ON Delay 1	<ol style="list-style-type: none"> Timing operation starts when START signal is ON at status of power on. Output will be ON when timing operation is progressed up to the setting time. Display value will be HOLD. (⓪ position) Even though START signal is applied repeatedly, only the initial signal is recognized. (Ⓛ position) When RESET signal is ON, display value and output will be reset. (Ⓨ position) 	
T > Ta		
[OND.2]		<p>Tout = output time T = set time</p>
ONDI		
ON Delay 2 (One-shot output)	<ol style="list-style-type: none"> Timing operation starts when START signal is ON at status of power on. Time limit output will be ON and goes OFF during Tout setting time when timing operation is progressed up to the setting time. Display value will be HOLD. (⓪ position) When RESET signal is ON, display value and output will be reset. If START signal is applied while time is progressing, Timing operation will be reset and started again. (Ⓛ position) Tout setting range: 0.01 sec to 99.99 sec. 	
T > Ta		
[FLP]		<p>Ton, Toff = set time Enables to set Ton and Toff time differently.</p>
FK		
Flicker (Toff operation precedes)	<ol style="list-style-type: none"> If START signal is ON, output will be repeatedly OFF during Toff setting time and will be OFF during Ton setting time when power is ON. When RESET signal is ON, display value and output will be reset. If RESET signal is OFF when START signal is ON, "STEP 1" will be restarted. When START signal is OFF, display value and output will be reset. It is able to set each Toff time and Ton time separately. In [FLP] mode, timing operation starts with Toff. 	
Ton, Toff > Ta		
[FLP.1]		<p>Ton, Toff = set time Enables to set Ton and Toff time differently.</p>
FK.1		
Flicker 1 (Ton operation precedes)	<ol style="list-style-type: none"> If START signal is ON, output will be repeatedly ON during Ton setting time and will be OFF during Toff setting time when power is ON. Even though START signal is applied repeatedly, only the initial signal is recognized. (⓪ position) When START signal is ON, display value and output will be reset. If START signal is ON, it will be restarted. It is able to set each Toff time and Ton time separately. In [FLP.1] mode, timing operation starts with Ton. 	
Ton, Toff > Ta		

※Initial status : UP mode-display value is "0", output is "OFF". DOWN mode-display value is "setting time", output is "OFF".

- (A) Photo electric sensor
- (B) Fiber optic sensor
- (C) Door/Area sensor
- (D) Proximity sensor
- (E) Pressure sensor
- (F) Rotary encoder
- (G) Connector/Socket
- (H) Temp. controller
- (I) SSR/Power controller
- (J) Counter
- (K) Timer
- (L) Panel meter
- (M) Tacho/Speed/Pulse meter
- (N) Display unit
- (O) Sensor controller
- (P) Switching mode power supply
- (Q) Stepper motor& Driver&Controller
- (R) Graphic/Logic panel
- (S) Field network device
- (T) Software
- (U) Other

LE4S Series

LE4S Output operation mode

T = Setting time, T > Ta

Mode	Time chart	Operation
[nEt] INT		
Interval	<ol style="list-style-type: none"> Output will be ON when START signal is ON at status of power on and Timing operation starts. Output will be OFF when timing operation is progressed up to the setting time. Display value will be HOLD. When RESET signal is ON, display value and output will be reset.(① position) If RESET signal is OFF when START signal is ON, 'STEP 1' will be restarted. When START signal is OFF, display value and output will be reset.(② position) 	T = set time
[nEt.1] INT1		
Interval 1	<ol style="list-style-type: none"> Output will be ON when START signal is ON at status of power on and Timing operation starts. Output will be OFF when timing operation is progressed up to the setting time. Display value will be HOLD. Even though START signal is applied repeatedly, only the initial signal is recognized.(① position) If START signal is ON after timing operation is progressed up to the setting time, Output will be ON and setting time will be reset and then timing setting starts. When RESET signal is ON, display value and output will be reset.(② position) 	T = set time
[nFd] ON OFF D		
ON-OFF Delay	<ol style="list-style-type: none"> If START signal is ON when power is on, Output will be ON when timing operation is progressed up to the Ton setting time(On-Delay). If START signal is OFF, output will be ON when timing operation is progressed up to the Toff setting time (OFF-Delay). If START signal is applied repeatedly, output is ON and display value will be reset.(① position) When RESET signal is ON, display value and output will be reset. When RESET signal is OFF while START signal is ON, it will be operating as On-Delay.(② position) It is able to set each Toff time and Ton time separately. 	Ton, Toff = set time
[nFd.1] ON OFF DI		
ON-OFF Delay 1	<ol style="list-style-type: none"> If START signal is ON when power is on, timing operation starts. Output will be ON when timing operation is progressed up to the Ton setting time(On-Delay). If START signal is OFF, output will be ON when timing operation is progressed up to the Toff setting time (OFF-Delay). Output will be ON when START signal is ON and goes OFF during setting time and display value will be reset.(① position) Output will be OFF when START signal is OFF and goes ON during setting time and display value will be reset.(② position) When RESET signal is ON, display value and output will be reset. When RESET signal is OFF while START signal is ON, it will be operating as On-Delay.(② position) It is able to set each Toff time and Ton time separately. 	Ton, Toff = set time
[oFd] OFF D		
OFF Delay	<ol style="list-style-type: none"> If START signal is ON when power is on, output will be ON. When START signal is OFF, timing operation starts. Output will be OFF when timing operation is progressed up to the setting time. Display value will be HOLD. When RESET signal is ON, display value and output will be reset. 	T = set time

※Initial status : UP mode-display value is "0", output is "OFF". DOWN mode-display value is "setting time", output is "OFF".

LCD Timer(Touch Type)

LE4SA Output operation mode

T = Setting time, T > Ta, Rt = Reset time

Mode	Time chart	Operation
[OND]		<p>T = set time</p>
OND	<ol style="list-style-type: none"> Timing operation starts when power is ON. Time limit output will be ON when timing operation is progressed up to the setting time. Display value will be HOLD. If selecting time limit 1c + instantaneous 1c mode, instantaneous output will be ON when power is ON and goes OFF when power is OFF. If pressing RESET key, display value and time limit output will be reset. 	
[OND2]		<p>Tout = output time T = set time</p>
OND2	<ol style="list-style-type: none"> Timing operation starts when power is ON. Time limit output will be ON during Tout setting time and goes OFF when timing operation is progressed up to the setting time. Display value will be HOLD. If selecting time limit 1c + instantaneous 1c mode, instantaneous output will be ON when power is ON and goes OFF when power is OFF. If pressing RESET key, display value and time limit output will be reset. Tout setting range: 0.01 sec to 99.99 sec. 	
[FLF]		<p>Ton, Toff = set time Enables to set Ton and Toff time differently.</p>
FK	<ol style="list-style-type: none"> Control output will be repeatedly OFF during Toff setting time and will be ON during Ton setting time when power is ON. If selecting time limit 1c + instantaneous 1c mode, instantaneous output will be ON when power is ON and goes OFF when power is OFF. If pressing RESET key, display value and time limit output will be reset. It is able to set each Toff time and Ton time separately. In [FLF] mode, timing operation starts with Toff. 	
[FLF.1]		<p>Ton, Toff = set time Enables to set Ton and Toff time differently.</p>
FK1	<ol style="list-style-type: none"> Control output will be repeatedly ON during Ton setting time and will be OFF during Toff setting time when power is ON. If selecting time limit 1c + instantaneous 1c mode, instantaneous output will be ON when power is ON and goes OFF when power is OFF. If pressing RESET key, display value and time limit output will be reset. It is able to set each Ton time and Toff time separately. In [FLF.1] mode, timing operation starts with Ton. 	

※Initial status : UP mode-display value is "0", output is "OFF". DOWN mode-display value is "setting time", output is "OFF".

※Instantaneous contact(OUT2) will be returned when power is off.

※RESET key is locked for default set and release the lock to use.

- (A) Photo electric sensor
- (B) Fiber optic sensor
- (C) Door/Area sensor
- (D) Proximity sensor
- (E) Pressure sensor
- (F) Rotary encoder
- (G) Connector/Socket
- (H) Temp. controller
- (I) SSR/ Power controller
- (J) Counter
- (K) Timer
- (L) Panel meter
- (M) Tacho/ Speed/ Pulse meter
- (N) Display unit
- (O) Sensor controller
- (P) Switching mode power supply
- (Q) Stepper motor& Driver&Controller
- (R) Graphic/ Logic panel
- (S) Field network device
- (T) Software
- (U) Other

LE4S Series

LE4SA Output operation mode

Rt : Reset time (Min. 500ms)

Mode	Time chart	Operation
[i n b] INT Interval	<p>1. Time limit output will be ON when power is ON and Timing operation starts. 2. Time limit output will be OFF when timing operation is progressed up to the setting time. Display value will be HOLD. 3. If selecting time limit 1c + instantaneous 1c mode, instantaneous output will be ON when power is ON and goes OFF when power is OFF. 4. If pressing RESET key, display value and time limit output will be reset.</p>	<p>T = set time</p>
[S - d] λ - Δ Star-Delta (Output will be set automatically as Time limit 2c)	<p>1. λ contact will be ON when power is ON and Timing operation starts. 2. λ contact will be OFF and T2 contact will be ON when timing operation is progressed up to the T1 setting time. Timing operation will be reset and started again. 3. Δ contact will be ON when timing operation is progressed up to the T2 switching time. Display value will be HOLD. 4. If pressing RESET key, display value and λ - Δ contacts will be reset. 5. It is able to set each T1 and T2 time separately.</p>	<p>※ T1 : set time T2 : switching time (λ-Δ switching time)</p>
[T U n] T Twin (Output will be set automatically as Time limit 2c)	<p>1. T1 contact will be ON when power is ON and Timing operation starts. 2. T1 contact will be OFF and T2 contact will be ON when timing operation is progressed up to the T1 setting time. Timing operation will be reset and started again. T2 contact will be OFF when timing operation is progressed up to the T2 setting time. Display value will be HOLD. 3. If pressing RESET key, display value and T1, T2 contacts will be reset. 4. It is able to set each T1 and T2 time separately.</p>	<p>T1, T2 = set time</p> <p>Enables to set T1 and T2 time same or differently</p>
[T U n. h] T1 Twin 1 (Output will be set automatically as Time limit 2c)	<p>1. Timing operation starts when power is ON. 2. T1 contact will be ON when timing operation is progressed up to the T1 setting time. Timing operation will be reset and started again. 3. T2 contact will be ON when timing operation is progressed up to the T2 setting time. Display value will be HOLD. 4. If pressing RESET key, display value and T1 and T2 contacts will be reset. 5. It is able to set each T1 and T2 time separately.</p>	<p>T1, T2 = set time</p> <p>Enables to set T1 and T2 time same or differently</p>

※Initial status : UP mode-display value is "0", output is "OFF". DOWN mode-display value is "setting time", output is "OFF".

※Instantaneous contact(OUT2) will be returned when power is off.

※RESET key is locked for default set and release the lock to use.

LCD Timer(Touch Type)

■ Proper usage

⚠ Caution

It may give an electric shock if touch the input signal terminal(Between START, RESET, INHIBIT and terminal ②) when the power is supplied.

◎ Power connection

- Connect AC power line between (②-⑦) for LE4S, LE4SA AC power type. Be careful of power connection for DC power type. (②← ⊖, ⑦ ← ⊕)
- LE4S, LE4SA work stably within range of rated power. (If using power line with another high voltage line or energy line in the same conduit, it may cause inductive voltage. Therefore please use separate conduit for power line)

◎ Power start

- Caution for power rising time(100ms) after power on and power falling time(100ms) after power off.

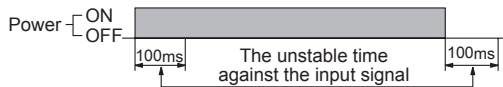

• Power ON Start

LE4SA model is starting after 100ms of supplying the power due to rising time of other devices (sensor, etc.) (refer to the above figure.)

For power ON Start, under 100ms setting may cause unstable operation. (it operates normally over 100ms setting)

For using under 100ms time operation, use LE4S, Signal ON Start type.

- Supply the power at once by a switch or relay contact, otherwise it may cause timing error.

◎ Input/Output

- Power terminal and Input terminal have not been insulated because there is no power transformer in this Timer.
- ① When using the sensor of SSR output type with input terminal of timer, please check whether Double insulated or not.
- ② Please use double insulated relay when connecting relay output with input terminal.
- Please use 8 Pin socket when connecting this Timer with other equipment and do not touch the socket when power on.
- Please use Power supply with over current protection circuit.(250V 1A fuse)
- When using relay contact as input signal, please use a contact that can function reliable at 5VDC, 1mA.
- In case of connecting START terminal (③) and power terminal (②) of LE4S, do not use it to start at the same time applying power.
- LE4S is transformer less type, therefore please check following for connecting relay contact for input signal and transistor.

- When connecting more than 2 timers with 1 relay contact for input or transistor, please wire following <Fig. 2 >. Please use relay contact or transistor to start. (Time error can occurs under 100ms setting because of rising time of Timer).

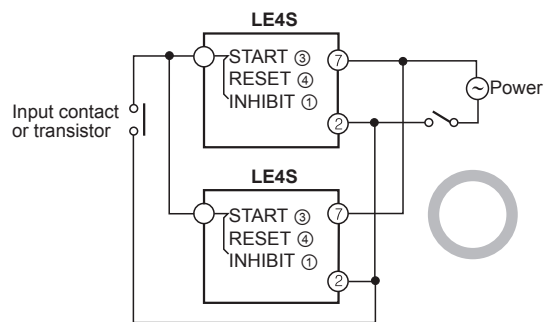
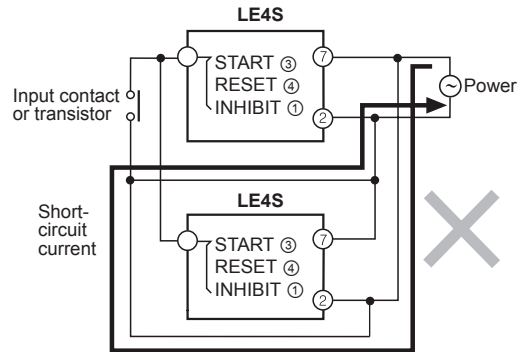

< Fig. 2 >

- Please use transformer with primary and secondary isolated for input.

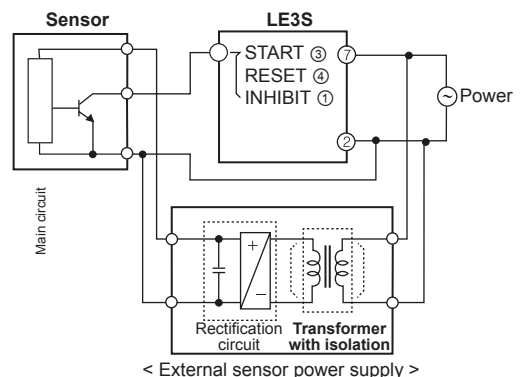

< External sensor power supply >

- Be sure that the specifications of this unit. Because when supplying the power to LE4SA, this unit operates instantly. (If supplying the power without the right checking, it may cause malfunction.)
- *and*, *and.1*, *and.2* operation modes are available to set as "0".

(A)	Photo electric sensor
(B)	Fiber optic sensor
(C)	Door/Area sensor
(D)	Proximity sensor
(E)	Pressure sensor
(F)	Rotary encoder
(G)	Connector/ Socket
(H)	Temp. controller
(I)	SSR/ Power controller
(J)	Counter
(K)	Timer
(L)	Panel meter
(M)	Tacho/ Speed/ Pulse meter
(N)	Display unit
(O)	Sensor controller
(P)	Switching mode power supply
(Q)	Stepper motor& Driver&Controller
(R)	Graphic/ Logic panel
(S)	Field network device
(T)	Software
(U)	Other

LE4S Series

⊙ Interval mode

It is able to make Instantaneous ON and time limit OFF (Holding device) with using interval mode.

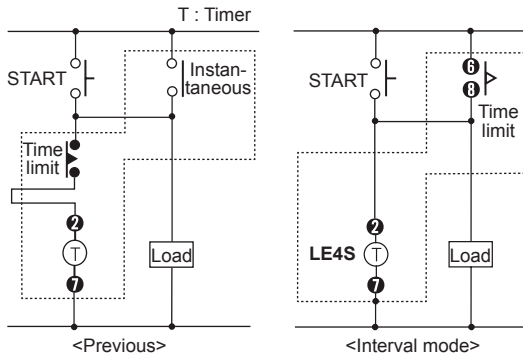

⊙ Change of output operation mode and timer range

If changing output operation mode or time range, previous reset value will be deleted.

But, UP/DOWN selection mode and lock mode are exception.

⊙ Change of preset value

- If changing setting value while time progressing, new preset value should be higher than previous preset value. Otherwise output may work while changing setting value.
- If changing setting value while it is running, it will work as changed setting value. Please use lock function in order to avoid malfunction.

⊙ Noise

We test 2kV, pulse width 1 μ s against Impulse voltage between power terminals and 1kV, pulse width 1 μ s at noise simulator against external noise voltage. Please install MP condenser (0.1 to 1 μ F) or oil condenser between power terminals when over impulse noise voltage occurs.

⊙ Environment

Please avoid the following places;

- Where this product may be damaged by strong impact or vibration.
- Where there are corrosive gas or flammable gas and water, oil, dust exist.
- Where magnetic and electrical noise occurs.
- Where there are high temperature and humidity beyond rated specification.
- Where there are strong alkalis and acids.
- Where there are direct rays of sun.